

The
London Journal and
Repertory of Arts, Sciences,
and Manufactures Vol. - 8
1834

Sas.
Librarian

Uttarpara Joykrishna Public Library
Govt. of West Bengal

■



THE
London
JOURNAL AND REPERTORY.
OF
Arts, Sciences, and Manufactures.

CONJOINED SERIES.

No. LIV.

Recent Patents.



To THOMAS SHARP, of Manchester, in the county palatine of Lancaster, and RICHARD ROBERTS, of the same place, engineers, for certain improvements in machinery for spinning and doubling cotton, silk, flax, and other fibrous materials, being a communication from a foreigner residing abroad.—[Sealed 8th October, 1834.]

THESE improvements in machinery for spinning and doubling cotton, silk, flax, and other fibrous materials, consist, firstly, in a peculiar construction or arrangement of the parts of a throstle frame for spinning and doubling; secondly, in the adaptation of upright drums for driving the warves or whirls in a throstle frame; thirdly, in a peculiar mode of mounting and driving the bobbins and the flyers in a throstle, for the purpose of causing them to revolve with distinct and dissimilar speeds; and, fourthly, in the adaptation of a peculiarly

formed spiral guide, sliding round a circular bead or rim, which guide is intended to act as a flyer in a throstle frame constructed to suit it.

For the purpose of more clearly illustrating these improvements, the Patentees have appended drawings, exhibiting the throstle frame in different positions, with the situations of the upright driving drums, and of the bobbins and flyers, and the manner in which they are actuated; also sectional figures of the bobbins and flyers detached from the machine; and likewise of a spindle with a pin-cop bobbin and the spiral guide in place of a flyer, with the manner of adapting this part of the invention to a throstle frame.

Plate XIV., fig. 1, represents a spindle *a, a*, upon which a disc *b*, is fixed, carrying the bobbin *c*. This spindle is made to revolve by a band from the driving drum passed round the warve or whirl *d*. A tube *e, e*, is affixed by its socket and screw nut to a stationary rail *f, f*; the upper part being bushed, to give steadiness, with little friction, to the spindle, which revolves within it, and is slidden up and down by the movement of the copping rail. On the outside of the tube *e*, another tube *g, g*, is fitted, carrying the flyer *h, h*, and warve or whirl *i*; and which last mentioned tube, with the flyer, is made to revolve by a band from the driving drum passed round the warve or whirl *i*. Hence it will be perceived that the bobbin and the flyer may be made to revolve by one driving drum at dissimilar speeds, according to the different diameters of the warves or whirls, and that, in this instance, the bobbin will run before the flyer; but, by driving the flyer with a speed nearly equal to that of the bobbin, the drag will be tempered, and a yarn of very high numbers may be readily spun and wound on the bobbin.

Fig. 2, is a variation of the same principle, in which the flyer *h*, is affixed to the top of the spindle *a*, in an inverted position, the tube *g*, carrying the bobbin *c*, being driven by the warve or whirl *i*, at a greater speed than the spindle and flyer is driven by the warve *d*, in order to effect the same object as described in reference to fig. 1.

Fig. 3, is a transverse section of a throstle frame constructed on the improved arrangement, in which the series of bobbins and flyers are driven by upright cylinders or drums, and showing the manner in which the driving bands pass from the upright drums to the warves or whirls of the spindles and of the flyers.

The end frames or standards of the throstle are shown at *a, a, a*, and *b, b*, on the longitudinal stationary rails, by which the ends are braced together, and the principal parts of the machinery supported: *c*, represents by dots the fast and loose pulleys, or rigger, over which a strap is passed from the first mover to drive the machinery; *d*, is the main shaft or axle, communicating motion to the working parts of the machine, and having a fly wheel and pulley affixed to its end, round which pulley an endless band passes over diagonal guide pulleys, and round the grooves at the upper parts of the upright drums *h, h, h*, for the purpose of giving rotary motion to the driving drums.

These drums *h*, turn upon vertical axles bearing in steps on a longitudinal rail at bottom, and are confined by a similar rail at top.

The spindles *i, i, i*, are ranged in series on each side of the frame, supported in steps at bottom by the coping rails *k, k*, and passed through tubes and sockets in the stationary longitudinal rails *b, b*. The construction of these spindles is the same as fig. 1, having a warve

or whirl affixed to each at the lower part, the bobbin bearing upon a disc mounted on the upper part of the spindle, and turning therewith; and the flyer is attached to a tube, as before described, and having a warve or whirl.

The coping rails *k, k*, supporting the spindles, are made to rise and fall, for the purpose of winding the yarns in uniform coils upon the bobbins by the ordinary contrivance, that is, by connecting those rails to pendant chains *l, l*, attached to rollers *m, m*; another chain *n*, attached to one of the rollers, and passed over the other, being made fast to one end of the lever *o, o*; which lever is mounted on a stud set in a transverse carrier rail *p*, and is made to vibrate by the rotation of the heart cam *q*, a cord and balance weight being attached to the reverse end of the lever.

In order to drive the spindles and flyers, bands or cords *r, r*, are passed round the respective warves or whirls of the spindles *i, i*, and round the upright drums *h*; and similar bands *s, s*, are passed round the respective warves of the flyers *j, j*, and also round the upright drums *h*; by which means, when the upright drums are made to revolve by the means before described, the spindles *i*, and flyers *j*, will be driven; and as the spindles ascend and descend, their driving bands or cords *r, r*, move up and down upon the periphery of the driving drums, always preserving the same altitude as the warves, and thereby keeping the bands or cords at all times at the same tension.

The cotton or other material in the state of rovings is placed in the machine upon large bobbins *u, u, u, u*, from whence it is conducted through the system of drawing rollers *v, v, v*, the upper or pressing rollers of the drawing system deriving their pressure from the transverse

bars *w*, bearing on their axles, which are drawn down by hooks *x*, with tension cords and weights *y, y, y*.

Having now fully exhibited and described the three first heads of our improvements, we proceed to explain the construction and adaptation of the spiral guide, to be used in place of a flyer, in the throstle frame.

Fig. 4, is a transverse section of a throstle, adapted to the employment of the spiral guide.

Fig. 5, represents one of the spindles *a, a*, on an enlarged scale detached, with its pin-cop bobbins *b, b*, shown in section; also the copping rail *c, c*, the step rail *d*, and the guide rail *e*, in section. A series of circular apertures are made in the copping rail, for the purpose of allowing spindles and bobbins to pass through. These apertures may be made to receive cylindrical sockets *f, f*, adjusted and held fast by a screw, as shown; or the apertures may be left open, without sockets. A ring *g, g*, (the upper side of which is represented at fig. 6, its under surface at fig. 7, and edgewise in section at fig. 8,) is to be affixed to the copping rail, either by fitting into the groove of the socket *f, f*, or by any other convenient mode of attachment, as by screwing down its rim *h, h*, to the copping rail. The form of the bead which constitutes the upper and inner edges of the ring *g*, is shown sectionally on a large scale at fig. 9, being of importance as to the correct working of the spiral guide represented at *i*, in the figs.

These spiral guides may be formed by binding a thin strip of steel, about the size of a watch spring, round a rod, as represented at fig. 10, so as to give it a screw or spiral figure; and when that figure is impressed upon the strip of steel, it is to be cut through longitudinally, that is, in the direction of the dotted line *a, b*, which will separate it into several distinct spiral pieces shown at

fig. 11; each of these pieces constituting one of the improved guides to be employed as a flyer. Or these spiral guides may be formed from steel wire coiled round a rod, at such an oblique angle as shall produce the required spiral figure.

A convenient mode of applying these spiral guide flyers in a throstle frame is shown in fig. 4, where the yarn, as it comes down from the drawing rollers, is represented as passing under the spiral guides, sliding on the beads or inner edges of the ring *g*, and from the guides the yarns severally pass to the barrels of the pin-cop bobbins on the spindles within. The spindles being made to revolve by bands from the driving drum, passed round their warves as usual, the tension of the yarn extending from the bobbin will drag the spiral guide, and cause it to fly round upon the bead at the edge of the ring, and thereby twist the yarn. But the friction, produced by the spiral guide rubbing against the ring as it revolves, will partially retard its progress; and therefore, as the spindle and bobbin must revolve faster than the spiral guide flyer, the yarn will be taken up or wound upon the pin-cop bobbin as well as twisted: the form in which it is wound upon the bobbin, that is the shape of the cop, depending upon the ascending and descending movement of the copping rail, which raises and depresses the guide; but the manner of effecting the form of the cop is well known, and constitutes no part of this invention.

In adapting the improved spiral guide flyer to throstle frames of the construction just described and shown in fig. 3, we find it convenient to mount the guide ring, fig. 6, round the bead of which the spiral flyer slides upon the tops of arms rising perpendicularly from a disc, with a tube turning upon the spindle, as shown in fig. 12.

By this arrangement, the spindle and bobbin may be driven one speed, and the ring which carries the spiral flyer at a dissimilar speed; which will afford the means of relieving the friction of the spiral flyer, and thereby tempering the drag to suit yarns of higher numbers and more delicate textures than are usually spun by throstles.—[*Inrolled in the Rolls Chapel Office, April, 1835.*]

Specification drawn by Messrs. Newton and Berry.

To WILLIAM JOHNSON, of the Horsley iron-works, in the parish of Tipton, and county of Stafford, gentleman, for his invention of a certain improvement or certain improvements in the construction of boots and shoes.—
[Scaled 22nd August, 1835.]

THESE improvements in the construction of boots and shoes are designed to afford simple, effective, and convenient means or modes of attaching and detaching the tension straps of trousers and gaiters in place of the ordinary straps employed for that purpose, which usually pass under the sole of the boot or shoe; and in that situation, are greatly exposed to wear, and collect dirt; are inconvenient in the manner of their attachment to the trousers and gaiters, and unpleasant to the wearer, by preventing the sole of the shoe or boot from being scraped clean, and the liability of the strap getting behind the heel.

The first mode which is proposed to be employed to correct these evils, is by forming a tube through the narrow part of the sole of the boot or shoe for the passage of a strap, cord, or chain, or for the reception of spring catches attached to the trousers or gaiters. The second mode is affixing metal studs or bars to the edges of the sole of

the boot or shoe, for the purpose of holding down the trousers or gaiters, by means of hooks, loops, or clasps attached thereto. The third mode is by affixing plates of metal to the sole of the boot or shoe, or by passing a plate of metal either under or through the sole, having projecting ends bent upwards, with slots, openings, or sockets, for the reception of spring catches, clasps, or studs, attached to the trousers or gaiters.

In the accompanying drawing, see Plate XV., fig. 1, represents a shoe constructed according to the first modification of the improvement, having a tube *a*, passed through the narrow part of the sole. This tube may be of thin metal quite through the sole, or it may merely have at the ends metal plates or sockets *b*. Through this tube a strap, cord, or chain, of elastic or non-elastic material, may be passed, the ends of which may be attached to the trousers or gaiters in any convenient way. Thus the trousers or gaiters may be held down, and some of the inconveniences above alluded to avoided; but I prefer to attach to the lower parts of the trousers or gaiters, spring catches with elastic straps; which catches I connect to the shoe or boot, by passing the catches into the tube *a*, and holding them fast by shoulders bearing behind the plate or in the sockets *b*. Fig. 2, represents one form of spring catch *c*, with the elastic strap *d*, supposed to be connected to the lower part of the trousers or gaiter by sewing, buttoning, or in any other convenient way; but I do not intend to confine myself to this particular form of spring catch. The catches *c*, being pressed into the sockets *b*, on each side of the sole, will, by means of their springs, hold the shoulder of the catch fast in the tube, and thereby afford the means of keeping down the trousers or gaiters with the desired tension.

The second modification of my invention is shown at

Sharp and Roberts's Imp. in Spinning

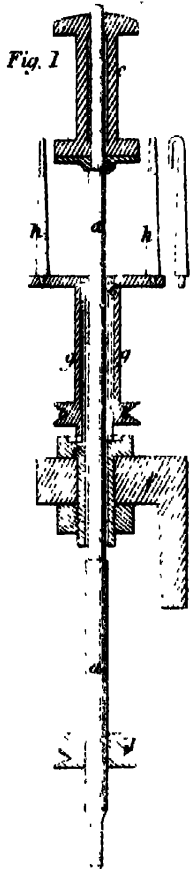

Fig. 1

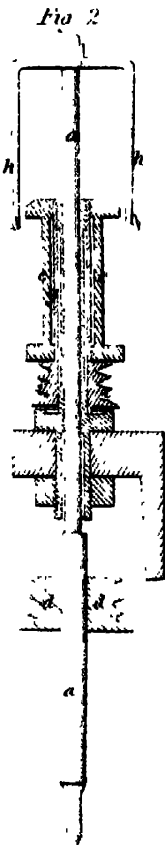

Fig. 2

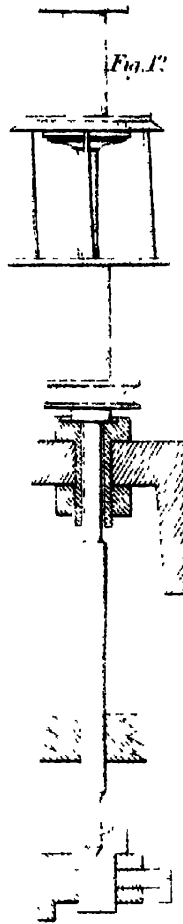

Fig. 3

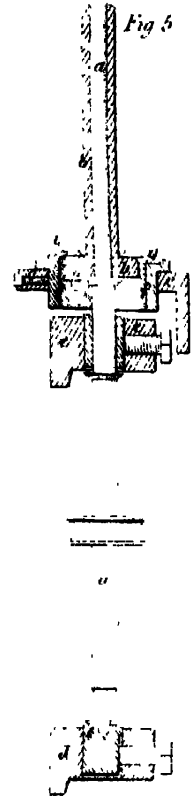

Fig. 4

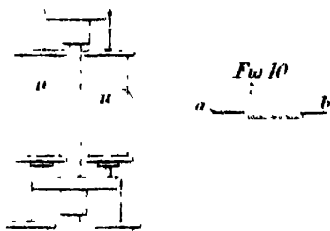

Fig. 5



Fig. 6

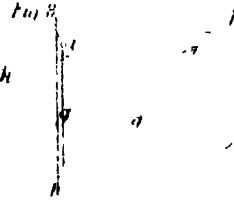

Fig. 7

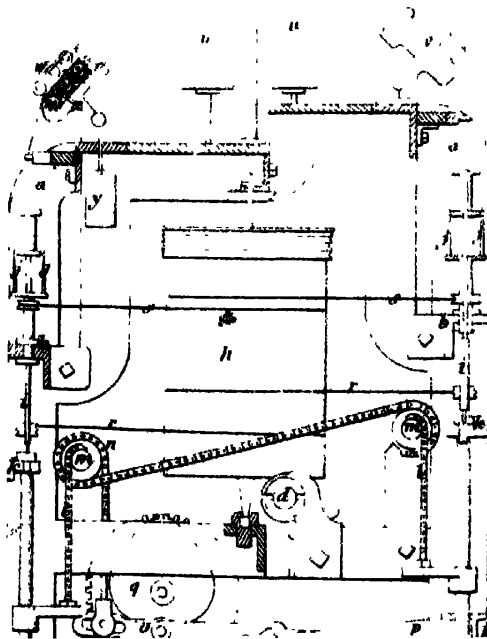

Fig. 8

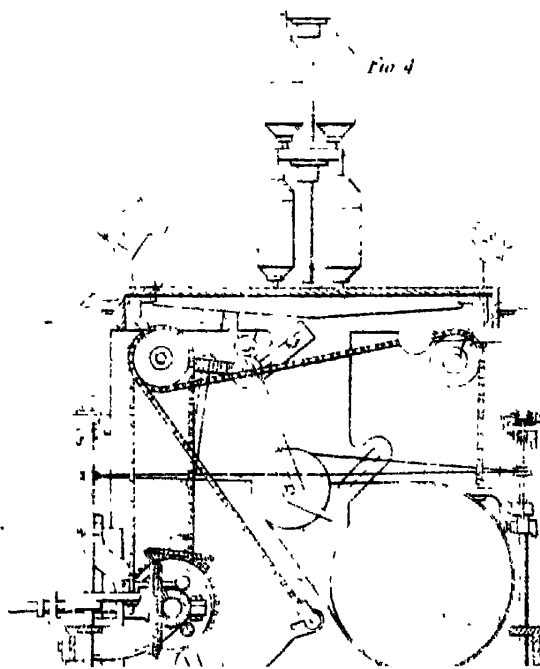

Fig. 9

fig. 3, and consists in inserting into, or affixing to, the edges of the soles of boots or shoes on each side a metal stud *e*, which may be done by driving or screwing a pin with a knobbed or enlarged head firmly into the edge of the sole, or by rivetting a stud into a plate, and affixing these plates and studs firmly to the sole on each side. Small staples, loops, catches, or hooks, as *f*, fig. 4, or in any other convenient form, being attached to the lower parts of the trousers or gaiters by straps *d*, (which I should prefer to be of elastic material) these catches *f*, may be readily hooked on to the studs *e*, at each side of the sole, and will then keep down the trousers or gaiters with suitable tension.

The mode of attaching tension straps to a boot or shoe by means of a bar, is shown at fig. 5: *o*, being the bar, affixed to the side of the sole by any convenient means. Fig. 6, represents a catch or hook *h*, with a spring *i*. This must be connected to the trousers or gaiters by a strap *d*, as fig. 4, and being hooked on to the bar *g*, on each side of the boot or shoe, it will hold down the trousers or gaiters securely. This bar *o*, may be affixed to the sole of the boot or shoe, or it may be made moveable, and be attached to the strap of the trousers or gaiters, in order to be connected to the boot or shoe when occasion may require, for the purpose of attaching the tension straps. The connexion of the bar *g*, to the boot or shoe may be variously effected: one mode is shown at fig. 7, in which the end of the bar at *k*, is bent down and inserted into a socket in the heel, the reverse end having a spring catch, which will hold it fast when pressed into a cylindrical socket in the sole, as at *l*; or the bar may be made in the form of a staple, as fig. 8, which being attached to the strap of the trousers or gaiter, its ends may be inserted into sockets, or a socket in

the sole, as *b*, fig. 1, and by a spring and catches, be made to hold fast when so connected to the boot or shoe.

The plate of metal proposed to be passed through or under the sole of the boot or shoe is shown detached at fig. 9; it is to be made fast to the sole by pins or otherwise. The ends of the plate are turned up at *b, b*, and slots are cut in them for the introduction of the spring catches, and to form the bearings before described, against which they shoulder; portions of the sole leather being, of course, removed, or a recess formed through the sole for the reception of the spring catches. To these plates, at their turned-up ends, may be affixed the metal studs or bars described above, for the hooks, loops, or clasps, to be connected to.—
[*Inrolled in the Rolls Chapel Office, February, 1836.*]

Specification drawn by Messrs. Newton and Berry.

To WILLIAM GODFREY KNELLER, of Mitcham, in the county of Surrey, chemist, for his invention of improvements in evaporation.—[Sealed 24th August, 1833.]

THIS invention applies principally to the evaporation of cane juice and saline liquors for the crystallisation of sugar and salt, and is described as consisting in the employment of certain apparatus or machinery capable of effecting the sudden compression of atmospheric air, which has been conveyed by means of inverted moveable chambers under the surface of the heated liquid about to be evaporated. The said volumes of air becoming expanded by the heat of the fluid, are made to pass beneath the lower edges of the chambers into adjoining chambers, and thence through holes in their tops through the superincumbered fluid.

This description does not appear to convey a very lucid illustration of the Patentee's intentions; but from an inspection of one of the figures of the apparatus, the scheme will be tolerably well understood. Plate XV., fig. 10, is a vertical section of a salt pan *a, a*, taken transversely, which may be supposed to be erected in brickwork, with a fire beneath it; or it may be heated in any other way, the brine occupying the pan up to the level shown by the broken lines. A vibrating apparatus *b, b*, called a ventilator, formed as a plate curved upwards, is mounted upon pivots, or an axle extending across the middle of the pan, and is by any convenient means made to vibrate, and so to dip into the liquid on both sides, as shown by dotted lines.

This ventilator is proposed to be constructed of iron, and is formed with sills in its under part, each of which sills will, of course, be occupied with atmospheric air. Now, on depressing the ventilator on one side, as shown by dots, the air contained in the sills of the depressed part will become heated, and, consequently, expanded, by immersion in the hot liquor, and will thereby be made to escape from the chambers, and pass upwards in bubbles through the liquor to the surface, carrying with it portions of the aqueous parts, and thus very greatly promoting the rapid evaporation and crystallisation of the saline matter. The returning vibratory movement of the ventilator will raise the immersed part, and depress the opposite, which will then cause the air contained in its sills to be discharged through the liquor in the same way.

Thus, by the reciprocating action of the ventilator, considerable quantities of hot air will be made to pass through the liquor, and promote evaporation of the aqueous parts of the saline or saccharine liquid.

The Patentee says, he does not intend to claim any particular forms or shapes in which this apparatus may be

made, but intends to avail himself of any fit and proper shapes, varying according to the kind of boiler or other apparatus to which it may be adapted ; and also constructs the ventilator of any suitable material, according to the liquid in which it is to be immersed, of which he takes a considerable range, as in the concentration of brines, medical extracts, alum, the manufacture of acids, the cooling of worts, glue and soap making, and in all cases where evaporation forms an essential part of the process.

It is also contemplated to use this apparatus in a close vessel, to assist in generating steam both of high and low pressure.—[*Inrolled in the Inrolment Office, February, 1834.*]

To SIR THOMAS COCHRANE, Knt., commonly called Lord Cochrane, of Regent-street, in the county of Middlesex, for his having invented an improved rotary engine, to be impelled by steam, and which may be also rendered applicable to other purposes.—[Sealed 11th November, 1830.]

THE construction of this rotary engine will be perceived by reference to Plate XV., fig. 11, which represents the engine in section taken transversely through the cylinder, the piston and its shaft.

The cylinder *a, a*, is fixed upon standards, having a shaft *b*, passed through it, which shaft carries a piston *c*, revolving within the cylinder. An internal cylinder *d, d*, made hollow and divided into two compartments, *e*, and *f*, is mounted in an eccentric position within the cylinder *a*, and there revolves, the peripheries of the two cylinders touching at bottom, where packing is placed to form a steam-tight joint. The ends of the cylinder *d, d*, also fit

accurately, and are packed against the interior of the cylinder *a*, so that no steam shall pass.

The steam from a boiler is intended to be introduced by a pipe into a recess in one end of the cylinder *a*, from whence it passes by an opening into the compartment *f*, of the inner cylinder, and thence through a passage in the piston to the part *g*, of the cylinder *a*, which becomes filled with steam; the other part *h*, of that cylinder, and the compartment *e*, of the inner one, with which it has an open communication, being kept in a state of vacuo.

It will now be perceived that the elastic force of the steam exerting itself in the space *g*, will force the piston round in the direction of the arrow, and hence give rotary motion to the shaft *b*, which may be communicated as a power for driving other machinery.

As the piston *c*, goes round with its shaft *b*, the inner cylinder *d*, *d*, is made to revolve also in the excentric position shown; and in so doing, as it approaches the lower part of the cylinder *a*, it will pass completely into the recess *f*, of the inner cylinder, at which time, by the position of the openings, the steam will be drawn off from the crescent-shaped chamber *g*, *h*, leaving that part of the engine in a state of vacuum; and as soon as the piston has passed the lowest point of its rotation, it will begin to protrude from the inner cylinder again, and the steam issuing from the passage in the piston will carry it round as before.

There are several modifications of this principle of operation proposed, very slightly varying in arrangement, but the Patentee says, that he does not consider his invention to consist in arrangement, but that he claims exclusively the employment of a lunate or crescent-shaped chamber, which is formed by two cylinders of unequal diameters placed excentrically, the periphery of one touching the other, and a piston sliding in and out the smaller cylinder.—[*Inrolled in the Inrolment Office, May, 1831.*]

To JOHN WALLACE, of Leith, North Britain, brasier, for his invention of an improvement or improvements in the safety hearth for the use of vessels.—[Sealed 31st March, 1831.]

THESE improvements are described as consisting, firstly, in a mode of “suspending” a ship’s hearth, or cooking apparatus, in such a way, that it may be enabled to preserve its perpendicular position when the ship rolls in a heavy sea; secondly, in the adaptation of a damper, for the purpose of changing the direction of the heated air and flame; and thirdly, in the application of a smoke jack in the flue or chimney.

Judging from the multitude of figures in the drawings, and the long, but unmethodical description accompanying them, it would be supposed that this was a very complicated affair, but the particular points in which the improvements alone consist are very simple, and the remainder of the matter is a mere cooking apparatus, or ship’s caboose, nearly of the ordinary construction.

Plate XV., fig. 12, represent the improved caboose in front elevation; fig. 13, the same, in sectional elevation, taken longitudinally. “The safety hearth is shown as placed on a curved stand or frame, which forms a railway upon which the hearth can move from side to side in case of the heeling of the ship, and whereby the hearth will be kept in its perpendicular position.”

The base on which the cooking apparatus is mounted is fixed to the deck, and has curved ribs *a, a*, as railways, upon which rollers *b, b*, attached to the under part of the caboose, are intended to run. This is called “suspending” it; when, by the rolling of the ship, the caboose is thrown out of the perpendicular, its gravity causes it to roll to the lowest part of the railway, and hence to preserve its erect position.

In the section will be seen a flap or shutter *c*, which turns upon an axle *d*, having a handle on the outside. This flap is intended to close occasionally one of the two parallel flues *e, e'*, for the purpose of damping or shutting off the heat of the fire *f*, either from the boiler *g*, or oven *h*; a current of air is admitted through an aperture in the side of the caboose into a channel *i*, between the fire *f*, and the oven *h*, which, becoming heated in its passage, descends to a bed of sand below the bottom of the oven, and thereby communicates heat upward to the oven in addition to that obtained from the flue above.

The smoke jack is introduced into the flue in an enlarged cylindrical pan *l*, the flyer *m*, being mounted on the top of a vertical shaft, which, as the flyer goes round by means of a worm or endless screw upon the shaft, drives the wheel and axle *n*, and hence by the pulley and chain *o*, turns the roasting spit in front of the fire at *p*.

The claim of invention is confined to the three features above, and not to the minor details of the apparatus.—
[*Inrolled in the Inrolment Office, September, 1831.*]

To GEORGE ROYL, of Walsall, in the county of Stafford, whitesmith, for his invention of an improved method of making iron pipes, tubes, or cylinders.—[Sealed 21st March, 1831.]

THE Patentee states, that he first bends up the edges of the suitable strips of iron to form the skelp of a gun barrel, or other pipe or tube, by any of the ordinary known modes of bending skelps; he then heats one half of the skelp at a time in an air furnace, or other fire, and

having so heated it, he passes the skelp between a pair of grooved rollers placed at the mouth of the furnace, for the purpose of uniting (or marrying, as he terms it) the edges of the metal ; that is, causing the edges of the open part of the skelp to be pressed together, and made to adhere and form a complete cylinder.

In order to enable the end of the skelp to be introduced between the rollers with facility, it is proposed to raise the upper roller by a lever connected to its carriage, and when lowered down again, and made to pinch the skelp, rotary motion is given to the rollers, and the skelp is by that means made to pass through, and the welding operation to be performed.

After the tube has been thus welded, it is to be passed between a pair of cylindrical dies, for the purpose of cleaning and scraping off the scales, and rendering the surface smooth. The upper of these dies is raised by a lever action, in order to introduce the end of the tube into the cylindrical hole : and when the end of the tube has been pinched between the dies, the tube is drawn through by tongs by any mechanical means actuated by a steam-engine, or other power.

The novel features of this operation are not pointed out ; and, as far as we can understand the Patentee's intention, he pursues exactly the same mode, and employs the same means, as are commonly resorted to for making ordinary gas tubing.—[*Inrolled in the Petty Bag Office, September, 1831.*]

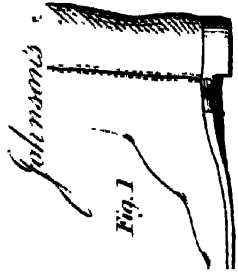

Fig. 1

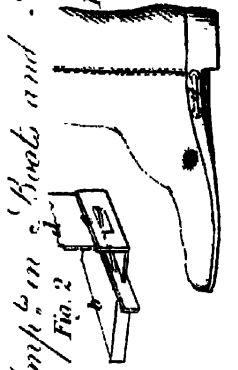

Fig. 2

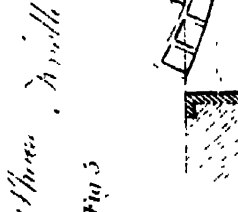

Fig. 3

Johnston's Improvement in Boots and Shoes

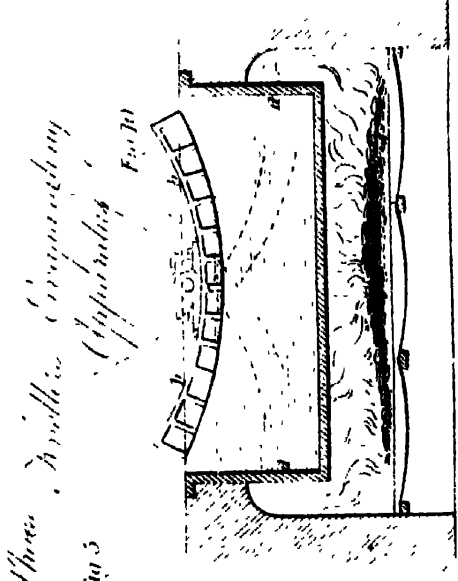

Fig. 4

Woolley's Improvements in Milling Machinery

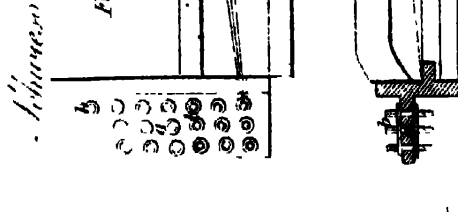

Fig. 5

Schweizer's Patent Fork

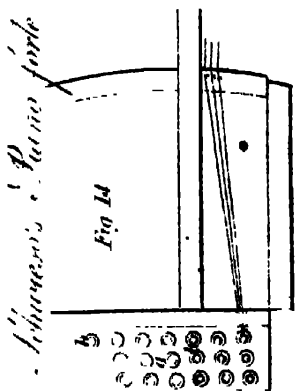

Fig. 6

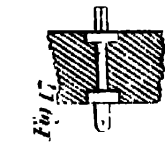

Fig. 7



Fig. 8

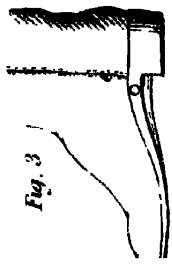

Fig. 9

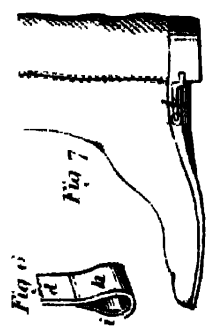

Fig. 10



Fig. 11

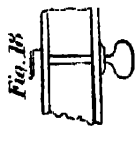

Fig. 12



Fig. 13



Fig. 14

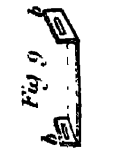

Fig. 15



Fig. 16

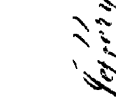

Fig. 17

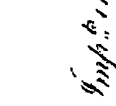

Fig. 18

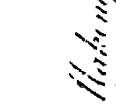

Fig. 19



Fig. 20



Fig. 21

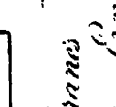

Fig. 22

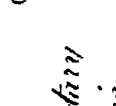

Fig. 23



Fig. 24

Walters' Shovel

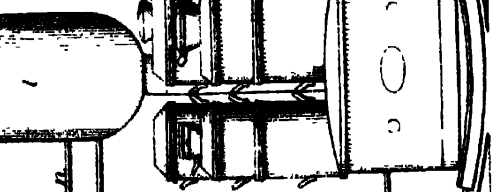

Fig. 25

Jefferys' Improved Shaking Buttons



Fig. 26



Fig. 27



Fig. 28



Fig. 29



Fig. 30



Fig. 31



Fig. 32



Fig. 33



Fig. 34



Fig. 35



Fig. 36



Fig. 37



Fig. 38



Fig. 39



Fig. 40

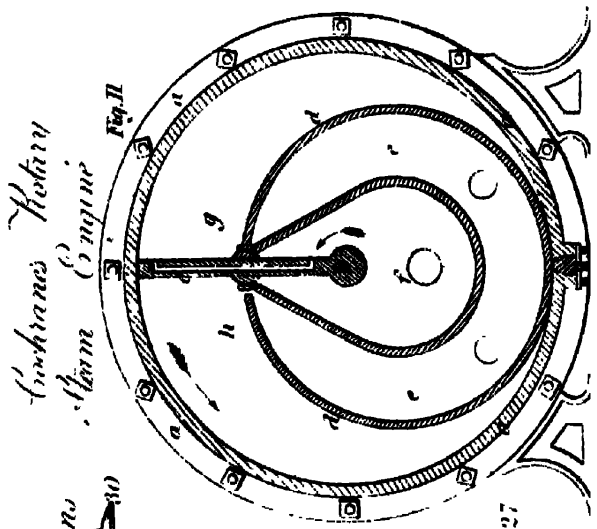

Cochran's Rotary Steam Engine

Fig. 41

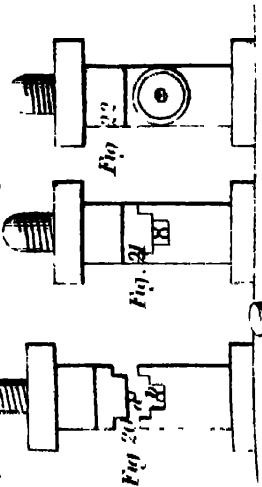

Fig. 42

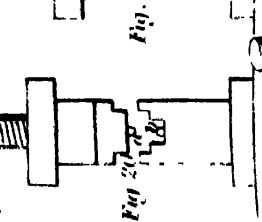

Fig. 43

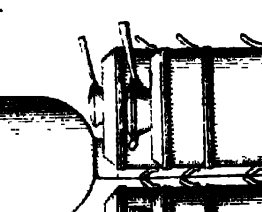

Fig. 44

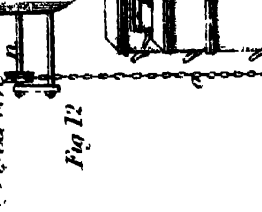

Fig. 45

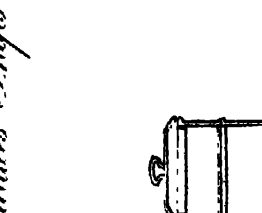

Fig. 46

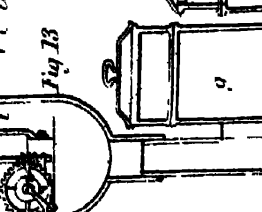

Fig. 47

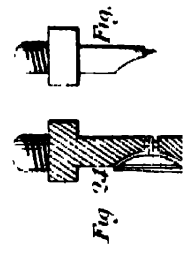

Fig. 48

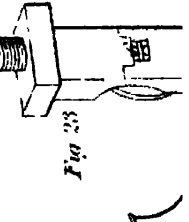

Fig. 49

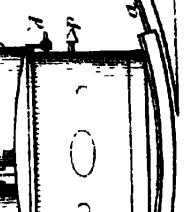

Fig. 50

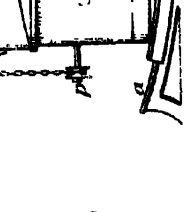

Fig. 51

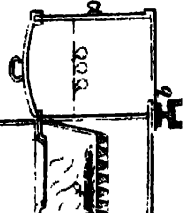

Fig. 52

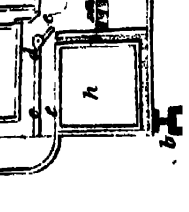

Fig. 53

To JOHN CHARLES SCHWIESO, of Regent-street, in the county of Middlesex, musical instrument maker, for his improvements in piano-fortes and other stringed instruments.—[Sealed 2nd February, 1831.]

THESE improvements relate to the manner of fixing the tuning pins of piano-fortes and other stringed instruments, in order to give such stability to the pins as shall keep the strings in tune. Plate XV., fig. 14, is a plan or horizontal view of that part of the piano-forte called the rest plank, to which is to be affixed an iron or other metal plate *a*, called the rest plate, for the reception of the pins *b*, the strength of the metal plate affording the required resistance to the tension of the strings, which cannot be obtained when the pins are set in wood.

Fig. 15, is a section of the rest plank and rest plate, taken transversely in a vertical direction. The holes drilled through the plate are countersunk on each side, for the purpose of receiving binding or friction collars, which are affixed to the tuning pins. Fig. 16, represents one of the tuning pins detached, having one fixed collar; the other collar is to be attached to it by passing over the square head, and screwing on to the shaft of the pin.

Fig. 17, shows the manner of adapting the pin to a harp, the pin being passed through the wood-work, which is shown in section; the same will apply to a guitar, if made smaller: and fig. 18, represents a tuning pin applied to a violin, or other such kind of instrument.

In conclusion, the Patentee says, that he claims, first, forming the rest plate which holds the tuning pins of cast-iron, or other sufficiently strong metal; and, secondly, constructing the tuning pins with two binding or friction col-

lars, whereby the proper pitch of the note of such strings will be more easily obtained.—[*Inrolled in the Inrolment Office, August, 1831.*]

To MARCEL ROMAN, of St. Michael's-alley, Cornhill, in the city of London, merchant, for certain improvements in, or additions to, apparatus or methods employed in throwing or winding silk, or other threads.—[Sealed 19th November, 1833.]

THE subject of this patent is an appendage to, as well as an improvement upon, the ordinary reel employed for winding off silk from bobbins, and reeling it into skeins, and consists of a train of wheels which are intended to operate by means of clicks at certain periods of the winding process, for the purpose of giving a longitudinal movement to the guides that conduct the threads to the reel. By means of this apparatus, when a certain length of silk or thread has been wound upon the reel, the guides move sideways, and cause the next coils of thread to be wound upon other parts of the reel by the side of the preceding. The advantages of this apparatus are, that when a number of skeins of equal length shall have been wound upon the reel, the train of wheels produces the lateral movement of the guides, and causes another series of skeins of the same length to be wound by the side of the former; and hence, when the operation is suspended, the several skeins may be taken off the reel all of equal lengths; and also that the train constituting a counting or measuring apparatus, will, at the end of certain lengths, throw itself out of gear, and cause the winding to cease.

This mechanism, consisting of many small wheels and pinions, with other minute parts, is necessarily complicated,

and requires many figures upon a large scale to render it evident: the description, too, is of considerable length; but as the subject is one of very limited application, we do not think it necessary to enter more fully into its details.—[*Inrolled in the Inrolment Office, March, 1834.*]

To BENJAMIN COOK, of Birmingham, in the county of Warwick, brass founder, for his invention of an improved method of making a neb or nebs, slot or slots, in shells or hollow cylinders of copper, brass, or other metal, for printing calicoes, muslins, cloths, silks, and other articles.
—[Sealed 1st November, 1830.]

THE subject of this patent refers to a temporary mode of confining cylindrical shells of copper upon an iron or steel shaft or axle in calico printing machines.

Two patents have been taken by Mr. Attwood, of Birmingham (with whom the present Patentee was, we believe, connected), for modes of attaching these shells of copper to their axles; the one by soldering, the other by means of corresponding ribs and grooves called nebs or slots, formed or cut in the internal surface of the shell and upon the axle. (See vol. x. of our First Series, page 307.) The present invention appears to have the same object in view; but instead of forming the said nebs and slots, as formerly practised, it is now proposed to cut them longitudinally, by means of what is commonly called a planing machine. The interior of the shell may be either truly cylindrical or excentric, or elliptical, corresponding with a similarly formed shaft or axle.—[*Inrolled in the Petty Bag Office, May, 1831.*]

To THOMAS SPINNEY, of Cheltenham, in the county of Gloucester, gas engineer, for his invention of an improved earthen retort for generating gas for the purpose of illumination.—[Sealed 17th November, 1832.]

THIS invention of an improved earthenware retort for generating gas for the purpose of illumination, consists of a combination of the following materials to form the earthenware of which the retort is composed; videlicet, Stourbridge fire-clay, burnt Stourbridge fire-clay, pipe or potter's clay, sand, sulphate of iron, commonly called green copperas, and potter's lead ore.

Very great nicety in the proportions in which the above materials are combined is not requisite, as the Patentee says he has found that the proportions may be varied, and yet a beneficial result obtained: his experience, however, induces him to prefer the following proportions.

Stourbridge fire-clay, one hundred pounds; burnt Stourbridge fire-clay, twenty pounds; pipe clay, twenty pounds; sand (which is recommended to be as free from lime as possible), twenty pounds.

The Stourbridge fire clay, the burnt Stourbridge fire clay, and the sand, are to be mixed together. The pipe or potter's clay must be well dried and broken into small pieces, and afterwards put into a copper or furnace, containing as much boiling water as may be requisite to dissolve or reduce it to the consistence of thick cream, which is to be added to the other materials previously mixed; and as much more water is to be added as will make the whole mass of such a consistence as will admit of its being tempered in the manner generally practised by potters.

The materials thus combined, may be moulded into retorts of any required form; but the Patentee says, I do

not mean hereby to confine myself to any particular form or size of retort ; they may be made in one or more pieces, as may be found most convenient. If made in one piece, after being dried, it must be brushed over with a glaze or cement composed of the following materials in the following proportions : of potter's lead ore, three pounds ; sand, four pounds ; sulphate of iron, one pound ; pipe or potter's clay, one pound. These are to be reduced to fine powder, and mixed with as much water as will bring them to the consistence of paint, and then applied with a brush in the same manner as paint is used by painters. The retort must then be removed to the kiln, and what is technically termed smoked from twenty-four to thirty hours, then gradually brought up to a white heat, and kept at that heat from twenty-four to thirty hours ; and afterwards cooled or let down in the usual manner of cooling down earthenware. If the retort is made in more than one piece, the pieces should be formed to fit each other, and joined together with the above-mentioned cement or glaze. The retort so formed is also to be brushed over with the said glaze or cement in the manner explained when the retort is made in one piece.

In conclusion, the Patentee says, I do not mean or intend to limit myself to the use of Stourbridge fire clay, but to avail myself of any other clay which may be fit for the purpose ; neither do I limit myself to the exact proportions of any of the materials above set forth, my invention being essentially the combination of the above materials to make an earthenware retort for generating gas for the purpose of illumination.—[*Inrolled in the Inrolment Office, May, 1833.*]

TO JOHN HEATON, WILLIAM HEATON, GEORGE HEATON, and RUBEN HEATON, of Birmingham, in the county of Warwick, manufacturers and co-partners, for their invention of certain machinery, and the application thereof to steam-engines, for the purpose of propelling and drawing carriages on turnpike roads, and other roads and railways.—[Sealed 6th October, 1830.]

THE subject of this patent is a locomotive engine intended to run upon ordinary roads. It is represented in the drawings in three very indifferently executed perspective views, and appears to be extremely complicated in its construction. The description of this machine, containing two steam-engines mounted on a frame supported by springs, and running upon four wheels, is so exceedingly long (occupying eleven skins of parchment), that we feel unable to condense it into any thing like an intelligible form. We can, however, say, that it contains no new features, beyond the precise arrangement of its multitude of wheels, pinions, cranks, rods, and levers. The elementary parts of the machinery, taken separately, are considered as old, and are, therefore, disclaimed by the Patentees; but the arrangement of the whole mechanism, in the way it stands, is claimed as a novelty. The particular utility, however, of this arrangement, the Patentees have not pointed out, and from a careful perusal we have not been able to discover it.—[Inrolled in the Petty Bag Office, February, 1831.]

To THOMAS JEVONS, of Liverpool, in the county of Lancaster, merchant, for an invention communicated to him by a foreigner residing abroad, of certain improved machinery to be used in manufacturing bar or wrought iron into shoes for horses, and also into shapes for other purposes.—[Sealed 8th October, 1835.]

THIS invention consists in the construction and employment of three distinct machines for effecting, in consecutive succession, the several parts of the operations of cutting, stamping, and forming the shoe, from a bar of red hot iron.

The first machine receives the bar of heated iron, which has been previously rolled to the desired width and thickness, and after cutting off the proper length to constitute one shoe, spreads the middle of the piece between a pair of rolling segmental swages, and then lets it fall upon an inclined plane, which conducts it toward the second machine. The workman then takes up the prepared piece of iron, still red hot and of a straight form, and by a pair of tongs, introduces it into the second machine, where, by the action of a pair of rolling segment dies, the grooves, and also the recesses for the nail holes, are indented in the face of the straight piece. From this machine, the prepared and indented piece of iron, still in a straight form, is conducted in a similar manner to the third machine, and is then, by the workman attending, introduced between a pair of excentric cam rollers, which bends the piece (still in a red hot state) into the curved form of a horse-shoe, or other desired form.

In the accompanying drawing, see Plate XVI., fig. 1, represents a side elevation of the first mentioned machine; fig. 2, is a horizontal view of the same, some of the upper parts of the machine being removed to show the other ope-

rating parts more clearly; fig. 3, is a sectional elevation taken longitudinally through about the middle of the machine; and fig. 4, is a sectional elevation taken transversely at right angles to the former, through the machine in front of the swaging segments. The several letters of reference indicate the same parts of the machine in these four figures: *a, a, a, a*, is a rectangular frame, standing horizontally upon legs, and supporting the working parts of the machinery; *b, b*, are two side standards, fixed to the frame, in which two tumbler frames *c, c*, vibrate upon centres. These tumbler frames move simultaneously, carrying a pair of segment cams *d, d*, which I call the swaging rollers, as between the peripheries of these cams the heated iron is passed in order to be compressed. A sliding carriage *e, e, e*, is supported upon horizontal ledges *f, f*, fixed to the inner sides of the frame *a*; which carriage is moved to and fro by a crank rod *g*, connected to the main driving shaft *h*. Upon the horizontal sliding carriage *e*, a pair of cheeks *j, j*, are mounted in jaws *i*, and *k*; the one *i*, is firmly fixed to the carriage, the other *k*, is moveable, as a lever upon a pivot at *l*, set into the carriage. In the moving jaw *k*, one of the pair of cutters *m, m*, is fixed, the other corresponding cutter *m*, is mounted in a lever *n*, turning upon a fulcrum pin at *o*; and when the heated rod of iron has been introduced into the machine at *A, A*, the closing of these cutters *m, m*, sever that portion of the length of the bar of iron which will be required to form one horse-shoe; at the same time the jaw *k*, closing, the piece of iron becomes confined laterally between the cheeks *j, j*, and the segment cams *d, d*, rolling, conduct the piece through, compressing and expanding its parts to the breadth and thickness of the required shoe, which constitutes the first part of the operation of making the shoe.

On the upper surface of the sliding carriage *e*, a hori-

Jevons's Imp^{ro} in Making Horse Shoes

Fig 8

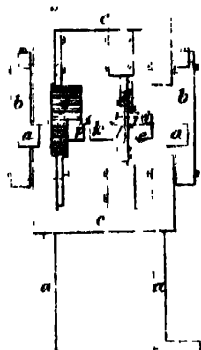
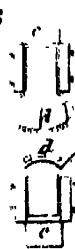

Fig 1

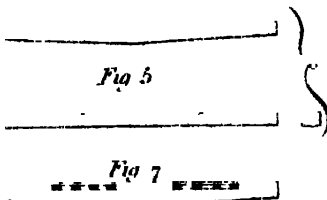

Fig 5

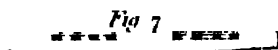

Fig 7



Fig 14

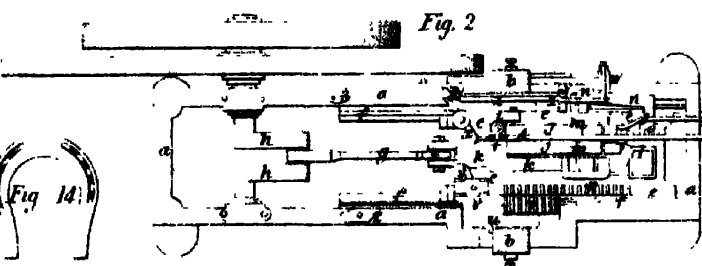

Fig 2

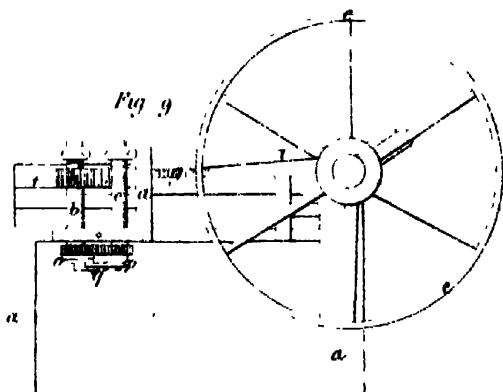

Fig 9

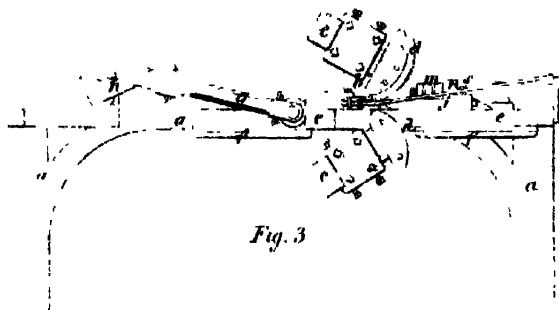

Fig 3

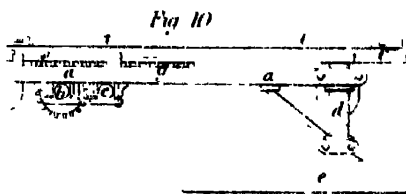

Fig 10

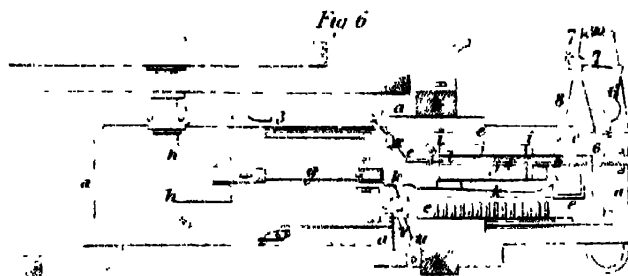

Fig 6

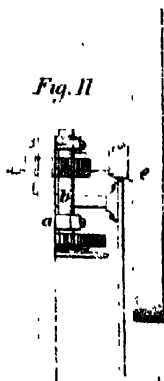

Fig 11

Brown's Ship Railway

Fig 15

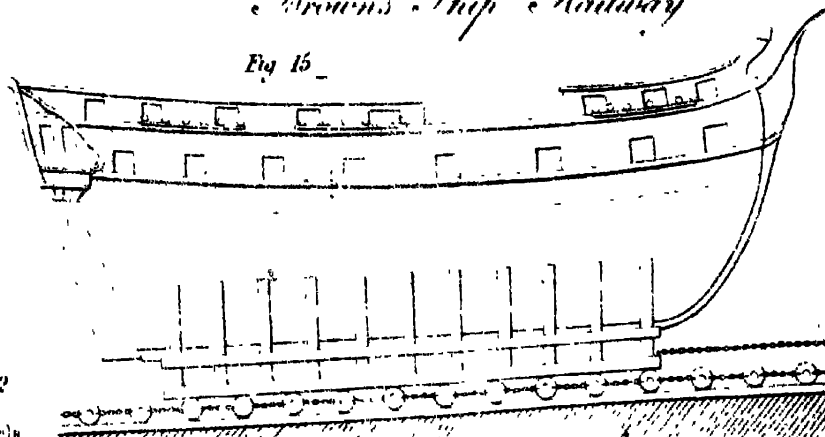

Fig 13



Fig 12



•

zontal rack p , p , is formed, which takes into a toothed sector q , affixed to the upper tumbling frame c . This upper toothed sector q , is made sufficiently wide to take into, not only the rack p , but also into another toothed sector r , affixed to the lower tumbling shaft; hence it will be perceived, that by the reciprocating sliding movements of the carriage e , worked to and fro by the crank rod g , the rack p , will, through the agency of the toothed sectors q , and r , cause the tumbling frames, with the segment cams d , d , to perform oscillating movements.

The general construction of the machine being now understood, I proceed to explain its details, and the manner in which it effects the desired object of cutting off the portion of iron from the rod, and compressing and expanding it. The required driving power being applied to the crank shaft h , the carriage e , e , will be slidden to and fro upon its ledges by the crank rod g ; and the segment cams d , d , will be made to reciprocate by the rack and toothed sectors.

The parts being situate as shown in fig. 3, the heated bar of iron is now to be introduced into the machine as represented at A , guided by a rest s , affixed to the front of the frame. The bar being pushed onward until its end comes against a stop piece t , the carriage e , e , in advancing, causes the back of the jaw k , (see fig. 2,) to be acted upon by the end of the wedge lever v ; the reverse end of which lever is brought in contact with a stop u , as the carriage proceeds, and the lever being thereby moved into a position at right angles to the back of the jaw, is made to push it forward by its wedge-like action, and the checks j , j , are thereby closed, and made to confine the bar of iron between them. By the same forward movement of the carriage, an inclined plane at the back of the lever n , is brought against an inclined stud w , which forces the lever n ,

forward, and with it the cutter *m*. By these means, the two cutters *m*, *m*, are brought together, as shown by dots in fig. 2; and the bar of iron *a*, being between them, is severed, leaving the piece of iron which is to form one horse-shoe between the cheeks *j*, *j*.

The further rotary movement of the crank shaft now slides the carriage *e*, backward, and in so doing, causes the rack *p*, to give the rolling action of the tumbling frames *c*, *c*, and to the segment cams *d*, *d*, which, in rolling, compress and expand the parts of the piece of iron to the required shape, as shown in different views at fig. 5.

It must be here observed, that in order to give the proper figure to the piece of iron, one of the cheeks *j*, must be slightly curved; and also, that the swaging cams *d*, *d*, must be made in a slight degree excentric and bevelled, so as to render the piece thinner in the middle, and on the edge intended to form the inner part of the shoe, and leaving the heel parts thick: of course, these may be varied to suit taste and circumstances, and for the purpose of producing other forms. At the commencement of the retrograde movement of the carriage *e*, a pin *y*, set in the upper surface of the lever *n*, works against the side of a bar *z*, *z*; and when this pin *y*, comes against the inclined plane *l*, on the side of the bar, the lever *n*, with the cutter *m*, is forced back, and brought into the situation shown in fig. 2, which opening of the cutters makes way for the rolling swages. The further retrograde movement of the carriage *e*, causes the tail of the wedge lever *v*, to come in contact with the stop 2, fixed on the side frame, which throws the lever into the oblique position, and allows the jaw *k*, to open. On the carriage *e*, proceeding a little further in its retrograde movement, the tail of the lever *x*, comes in contact with another stop 3, fixed on the opposite side of the frame; which stop brings the lever into a position at right

angles to the carriage, and causes it to force back the moving jaw *k*, which releases the piece of iron from beneath the cheeks *j, j*, and allows it to fall through into an inclined plane placed beneath the machine, by means of which the piece is conveniently conducted towards the workman, who instantly places it in the second machine, where it is to be stamped, that is, the grooves and nail holes formed.

The construction of the second machine is the same in most of its operating parts as that already described. The piece of iron is put into the machine in the same situation as the red-hot bar was first introduced, and the piece is passed between segment rollers in the same manner; but in this machine the segment rollers are dies, by means of which the grooves and recesses for the nail holes are formed.

Fig. 6, is a horizontal view of the second machine, partly in section as fig. 2, the upper tumbling frame *c*, the tooth sector *q*, and upper segment die, being removed, to show the other working parts more clearly. A narrow bar 4, extends horizontally about half-way between the cheeks *j, j*, in the jaws *i, k*. This bar is fixed to the front of the frame *a*, and upon it, between the cheeks, the piece of hot iron prepared in the former machine is to be placed.

In order to bring this piece of iron into a situation for the rolling dies to act properly upon it, a projector 5, is made to slide horizontally on the upper surface of the bar 4. This projector is attached to one end of a double-armed lever 6, 6, turning horizontally upon a fulcrum pin, fixed in the front part of the frame *a*. Now, as the carriage *e, e*, advances, one end of a right-angled lever 7, 7, mounted in a bracket arm 8, extending from the carriage, comes in contact with the outer end of the double-armed lever 6, which causes the projector 5, to push the piece of iron into the proper situation between the cheeks; and

when the projector has moved sufficiently far, it is withdrawn by the force of a spring 9, acting upon the double-armed lever 6, the right-angled lever 7, having been withdrawn from the end of the lever 6, by an adjustable stop 10, fixed at the side of the frame. The receding of the carriages *e, e*, now causes the rolling dies to act upon the piece of heated iron as it passes between them; but in this instance its figure is not altered, the upper rolling die simply impressing the surface of the piece of iron, and forming the grooves and recesses for the nail holes, as shown in fig. 7, which represents the piece in the second stage of the operation of making a horse-shoe. The further receding of the carriage *e, e*, brings the levers against the stops, as described in reference to fig. 2, by which the jaw *k*, is opened, and the piece of iron let fall on to an inclined plane, ready to be taken and introduced into the third machine.

Fig. 8, shows the pair of rolling dies mounted in the tumbling frames, as they would appear on the reverse side to fig. 3. The edges of the dies are bevelled, to form the grooves in the horse-shoe; and these are made with projecting studs or points, which produce the impressions for the nail holes. It is scarcely necessary to say, that these dies are adjustable by screws shown in the last described figure.

The machine for effecting the third part of the operation, that is, bending the piece of iron into the form of a horse-shoe, is shown in side elevation at fig. 9, in horizontal view at fig. 10, and in front elevation at fig. 11: *a, a, a*, is the framework, in which are mounted two spindles or vertical shafts *b*, and *c*. Upon the end of a horizontal shaft *d*, a pulley *e*, is fixed, round which a driving strap is to be passed, communicating with the steam-engine, or other first mover. A horizontal sliding bar *f*, is mounted in

grooved brackets at the back of the frame, on the face of which bar a rack or row of teeth g, g , is formed. Upon the vertical shaft b , a toothed wheel h , is mounted, which takes into the rack g , of the sliding bar. At the back of the framework a crank rod i, i , is connected at one end to the sliding rack bar by a joint k , and at the other end to a crank l , on the back end of the driving shaft.

Fig. 12, is a horizontal section of the vertical shafts b , and c , with the excentric gear m , and n , affixed to the lower parts of those shafts. At the bottom of the shaft b , the block o , for forming the shoe, is affixed; and at the bottom of the other shaft c , the cam or follower p , is attached, and also the plate q , intended to operate as a guider in the act of bending the piece of iron round the block.

Fig. 13, is a horizontal view of the lower ends of the spindles b , and c , with the block o , and following cam p , their reverse or under sides being represented upwards. The piece of iron prepared as above described, is to be introduced into this machine in front, as shown at Λ^* , in figs. 12, and 13. A small nipper lever r , turns upon a pin set in the bent arm s , extending from the back of the block; which nipper lever, on the opening of the cams (that is, the block and follower) to receive the piece of iron to be bent, is brought into the position shown in figs. 12, and 13, taking hold of the end of the piece of iron, and keeping it firmly against the block. Rotary motion being now given to the spindle b , by the sliding rack bar f , actuated by the crank l , as described above, the excentric gear m , and n , of the two spindles b , and c , with the block o , and follower p , will revolve together, and cause the piece of iron Λ^* , to be bent round to the shape of the block o , which finishes the operation of forming the horse-shoe, fig. 14. On the nipper lever r , coming round, it will strike against the end of a

curved horn *t*, attached to the block of the follower, which will throw open the nipper lever, and allow the shoe to fall down from the machine.—[*Inrolled in the Rolls Chapel Office, April, 1836.*]

Specification drawn by Messrs. Newton and Berry.

To JOHN COLLINGE, of Lambeth, in the county of Surrey, engineer, for his having invented an improvement or improvements on the apparatus for hanging or suspending the rudders of ships or vessels of different descriptions.—
[Sealed 1st November, 1830.]

THE subject of this patent is merely the adaptation to a ship's rudder (in place of the pintle) of the ball and socket hinge, which the Patentee invented and obtained a patent for in November, 1821. (See vol. vi. of our First Series, p. 249.)

The upper bearing joint or pintle of the rudder is formed with a spherical end bearing in a cup or concave hemispherical socket fixed to the stern post. The ball has a groove formed round it in a vertical direction, for the purpose of allowing oil to flow freely to lubricate the joint, and a leather cap is placed over the ball and socket for the purpose of excluding the sea water.

By this contrivance it is considered that the rudder of a ship may be more readily shipped and unshipped when required, and that the wear will be more uniform, the rudder more steady in its action, and the joint or pintle less likely to be broken off.—[*Inrolled in the Petty Bag Office, May, 1831.*]

To CHARLES STUART COCHRANE, of Great George-street, in the city of Westminster, Esq., in consequence of a communication made to him by a certain foreigner residing abroad, for certain improvements in the preparing and spinning of Cashmere wool.—[Sealed 13th November, 1830.]

It is stated by the Patentee, that the wool of the Asiatic or Thibet shawl goat, called Cashmere or Indian wool, has not hitherto been prepared in Great Britain; but that all the imitations of Cashmere shawls, and other goods of that description, which have been manufactured in this country, have been woven here from yarns prepared and spun in France, and imported into this country, and that it has been much desired that the French process of preparing and spinning this material should be made known to British manufacturers. In consequence of this information being required, the Patentee has procured from M. Hinderlang, of Paris, the particulars of the manner in which he prepares the Cashmere wool in his factory; which process forms the subject of the present patent.

The wool, after being unpacked from the bag in which it is imported from India, is spread out upon a sort of large sieve, and beaten with sticks by women, for the purpose of opening its fibres and clearing away the dirt: when that has been done, the wool is to be washed in water with soft soap and sorted, the coarse hairs being picked out by children; and after such sorting and picking, the finest portions of the wool are to be combed, as is usually done in preparing wool for spinning worsted, and bleached by the process of sulphur. The short and inferior part of the wool left in

the teeth of the combs is to be sold with the coarse hair to hatters; and the long wool thus prepared by combing, &c. is then operated upon in the way usually practised in making worsted goods.

The second or inferior quality of Cashmere wool, suited for spinning up to No. 45, after having been opened, picked, and washed as above, is introduced into a preparing machine, constructed with a series of revolving cylinders placed in a consecutive horizontal range, the several cylinders being covered, every other one with bristles, and the intervening ones with needle points. Into this machine the wool is fed between rollers; and as it is drawn along, its fibres become straightened by the rotary action of the bristles and needles, and at the end of the range is wound upon a drum in the ordinary way of capping. The lapped roll of wool is then taken to a carding engine, and carded as usual; from whence it is conducted between drawing rollers, and is then roved, slubbed, and spun in the ordinary way.

The Patentee says, that he does not claim any of the machinery employed as new, excepting that first described for operating upon the inferior quality, consisting of cylinders of brushes and points; and that his claim consists in preparing Cashmere wool for the manufacture of imitation Indian shawls, and such kind of goods which has never before been done in these kingdoms.—[*Inrolled in the Petty Bag Office, May, 1831.*]

To HUMPHREYS JEFFERY, of Birmingham, in the county of Warwick, goldsmith and jeweller, for his invention of certain improvements in buttons.—[Sealed 28th November, 1835.]

THIS invention is described as an improvement in those kinds of metallic shanks which are raised or formed out of the piece of metal intended for the button or button back, and also in an improved shank made of wire, and fastened to the button blank by means of a stamp or press, without the use of solder or any other extraneous matter. To make a button, commonly called a brace button, also the back or underside for a metallic shell button, or for a Florentine silk cloth or other covered button, I take a circular piece of sheet iron, or other metal suitable for the purpose, and of the requisite size and substance, and by stamping or pressing the back or underside of the button with a rim at the edge, and a swell in the centre, as shown in the drawing, see Plate XV., fig. 19 : I then, by means of a pair of piercing tools, figs. 20, and 21, holding the button bottom in the form or position shown in figs. 22, and 23, cut or pierce two sides of the central swell (which swell may be either circular or oblong), and at the same time turn the edges of the metal where so cut or pierced, and intended to form the shank under and not over the shank, in such manner as to round the edges in all parts, to avoid cutting the thread or cloth.

The edges so turned should not be made merely to approach or go near to each other, but they should be actually doubled under until they touch the underside of the shank, and be pressed against it ; and it is a feature of this mode of forming the shank by doubling under the edges of the elevated and pierced centre, that it may be done in iron as well as in copper or brass ; the operation and the tools used in effecting it are of the most simple description.

The iron for the button back must be the best charcoal iron, and it should be annealed during the process. Fig. 25, shows the concave side of the button back, and 26, the convex side, with the shank complete.

The tools used for cutting or piercing the shank, and at the same time turning or rounding the edges thereof, must be formed with great accuracy in order that they may take off the rough edges of the metal forming the shank, otherwise if any rough or sharp edge be left, it will cut the button-hole, and also the thread or other material, in sewing the button on the garment. Fig. 20, shows the punch *a*, and the bed *b*, in the position for piercing and bevelling and throwing back the edges; and fig. 21, the same tools when the shank is pierced. Fig. 24, shows a section of the piercing and bevelling punch, one side being flat and the other round; and fig. 23, *F*, shows a perspective view of the piercing tools with the button in them; figs. 22, and 23, show respectively the outside and inside of the button back in the act of piercing.

To make solid metal buttons, take a common metal button shank of the size required, and by means of a stamp or press from two small square concavities, (see fig. 28) near the centre, at proper distances, to receive both ends of the shank; I then take a common button shank of the form shown by fig. 29, the ends of the shank being made to fit into the concavities of the button blank; I then put the shank into a shank die with the ends inserted into the concavities of the blank, and then with a top die to be forced or struck down upon it by means of the press or stamp, unite or fasten the shank and blank together, and at the same time by the use of the press or stamp impress upon the button any fancy pattern if required. Fig. 30, shows this shank complete.

Now, whereas I claim as my invention the following improvements, (that is to say) the improved shank to the brace

button or bottom for a metallic shell, Florentine or other covered button, which shank being raised as aforesaid out of the metal, is so cut or pierced that the edges of the shank are turned under as aforesaid, which turning under prevents the cutting the thread of the button-holes complained of in the raised and cut or pierced shank, the edges of which are not turned under as aforesaid. Secondly, the wire shank fixed or rivetted to the button without the use of solder.—
[*Inrolled in the Inrolment Office, May, 1836.*]

[The same object, viz. making apertures in a button shank pressed out of a metallic disc, formed the subject of a patent granted to Dr. Church, 26th March, 1829.—[See our Second Series, vol. v. p. 249; and also another patent to John Holmes, 4th May, 1833. See the present conjoined series, vol. iii. p. 69.—EDITOR.]

To DAVID NAPIER, of Warren-street, Fitzroy-square, in the county of Middlesex, engineer, for his having invented certain improvements in printing and in pressing machinery, with a method of economising power applicable to the same; which method of economising power is also applicable to other purposes.—[Sealed 13th October, 1830.]

THESE improvements are divided into four distinct heads; the first of which apply to a rotary printing machine, the second to an inking apparatus, the third to pressing paper after it has been printed and dried, and the fourth to a means of overcoming the dead point of a crank or winch.

The general features of the machine are the same as those usually employed for printing, called Napier's, having two printing cylinders, two tables and forms of type, and in

which the sheets of paper are conducted by endless tapes from the laying-on boards above. The Patentee has therefore not considered it necessary to describe the whole machine in detail, as most of its parts are old and well known.

The first head of the invention is described as consisting in keeping two printing cylinders in rotary motion by their being acted upon by two reciprocating racks. The construction is this—two horizontal tables with their respective forms of type are connected together, mounted upon rollers set in the side frames, which enable the tables to travel to and fro horizontally; two printing cylinders placed across the machine turn with their axles in bearings upon standards at the sides of the frame, for the purpose of pressing the paper upon the forms of types as it passes beneath, and thereby obtaining the impressions. The axle of each cylinder has a pulley or rigger affixed to it, and these are connected together by a band which is crossed, so that when rotary motion is given to one axle by a winch or by a crank and steam power, both cylinders turn in opposite directions.

A horizontal rack is fixed at the side of each table, and upon the axle of each printing cylinder a wheel turns loosely: these wheels have half their circumference cut with teeth, intended to take into the rack, and the other half plain. At the side of each of these wheels a spring click or catch is attached, which is, by its spring, brought into contact with a stop in the end of each cylinder; hence it will be perceived, that as the cylinders keep continually revolving, the spring click or catch will cause the wheels to be carried round with the cylinders.

The half circle of teeth of one wheel being, as the wheels revolve, brought into gear with one of the horizontal racks, the tables, with the forms of type, will be carried along under the printing cylinders; the one to produce the impres-

sion upon a sheet of paper conducted on to it by tapes, the other to receive its ink from the inking rollers ready to give to the next impression.

By this horizontal movement of the tables, the other rack, at the reverse end, will now be brought into gear with the half circle of teeth on the other wheel; and, as the printing cylinders continue revolving in opposite directions, the tables and forms of type will now be slidden the reverse way, and a sheet of paper be printed from the form last inked. Thus, the reciprocating horizontal movement of the tables and forms are produced, and the machine is made to give impression to the sheets of paper as it traverses to and fro.

The second head, is the adaptation to the above printing machine, that combination of levers called Bolton and Watt's parallel motion, for the purpose of conducting the inking rollers to and fro, for the purpose of receiving the ink from the duct and depositing it upon the types. This apparatus may be worked by hand, or by any convenient mechanism connected with the rotary motion of the cylinders.

The third feature of the invention, that is, pressing the sheets of paper after they have been printed and dried, is intended to supersede the old press worked by a screw, or by hydrostatic power, and consists in passing the sheets between a pair of rollers covered with glazed paper. This is only to be considered as new, in its application to pressing paper which has been printed.

The fourth object, viz. that of economising power, is by applying a coiled spring, like those employed in clocks, to assist in passing a crank or winch over the dead point of its rotation. This spring may be so connected, that it shall exert its power at the dead point, and be wound up into tension when the crank or winch has its full power. A lever is proposed to be attached to the barrel of the spring

for the purpose of bringing it into tension; which lever may be raised by hand, or by any connexion with the stroke of the steam piston; and it is suggested that this contrivance may be adapted to other machinery where the crank or winch is employed.—[*Inrolled in the Inrolment Office, April, 1831.*]

To JOHN TYRRELL, of St. Leonard's, in the county of Devon, Esq., barrister-at-law, for his invention of a method and apparatus for setting sums for the purpose of teaching some of the rules of arithmetic.—[Sealed 13th November, 1830.]

THIS is one of the most extraordinary schemes that we ever remember to have seen dignified with the title of patent. This “*apperatus, for setting sums for the purpose of teaching some of the rules of arithmetic,*” is described as consisting simply of several strips of parchment or stiff paper, on which numerical figures are to be written. These strips are to be placed one above the other, and wound upon small rollers enclosed within a box, in which a small aperture is cut for the purpose of exposing to view so many of the figures only as are required, when arranged, to constitute the sum intended to be worked, which is done by drawing along or winding up the strips until such figure are seen through the aperture.

No directions are given as to any mode of applying these figures, or of working the sums, nor is any novelty in the process of making the caculation proposed; it seems that the apparatus above described is merely designed to show the figures of a sum in black and

white, in order to save the trouble of writing them upon paper or upon a slate.

Apertures of different shapes are proposed to be cut in different boxes, and strips figured in different ways, to suit the kind of sum to be stated in either of the four first rules of arithmetic, whether in simple numbers, or of pounds, shillings, and pence, or of weights or measures.

It is proposed that a teacher, after having set any sums by arranging the figures in certain ways, shall cast them up and write the result in a pocket book, in order that, at a future time, when looking over a pupil with the same sum, he may refer to his book, and save the trouble of casting it up. This appears to be the whole matter of the invention.—[*Inrolled in the Inrolment Office, May, 1831.*]

To SAMUEL BROWN, of Billiter-square, in the city of London, commander in the royal navy, for his invention of certain improvements in the means of drawing up ships and other vessels from the water on land, and for transporting or moving ships, vessels, and other bodies on land from one place to another.—[Sealed 6th December, 1830.]

IN order to effect the drawing of ships from the water on to land, a strong tramway of three parallel lines of large stones is to be laid as an inclined plane, extending from the land down into the water to the low water mark. Upon this tramway the ship is to be drawn up out of the water, by first floating a cradle under her hull when she rides high enough in the water, as at high tide; and then having brought the cradle, with the vessel in it, exactly over the

tramway, and placed rollers under it, she is allowed to come to rest in that situation when the tide has subsided. A drag chain is then attached to the hull of the vessel, and by means of a windlass or capstan, worked by manual, or by steam, or any other power, the cradle with the vessel is drawn forward upon the rollers until she is completely upon the dry land.

Plate XVI., fig. 15, shows the manner in which a vessel would be conducted upon an inclined plane from the water. This mode of drawing a ship from the water on to dry land, appears to us to be precisely the same as the mode proposed by Mr. Thomas Morton, of Leith, and for which he obtained a patent in March 1819. (See the First Series of the London Journal of Arts, vol. i. p. 17.)

The present Patentee, however, states, that one of his principal novel features is the adaptation of a chain of rollers to be placed under the cradle, to assist in drawing the vessel forward, instead of pulleys or wheels turning upon axles attached to the frame or cradle, and running upon the edges of iron rails.

The construction of these chains of rollers are not very well explained, but as far as we understand the Patentee, there are to be series of long rollers connected by chains attached to their axles; and that three series of these chains of rollers are to be employed, one rolling upon each of the lines of stone railway, and supporting the cradle with the vessel; and that edge rails of iron are to be placed to the rollers to prevent them from deviating out of their direct course.

Having brought the vessel to land in the cradle upon rollers, the Patentee proposes that it may be, in like manner, conducted to any desired distance over land by means of truck chains or ropes drawn by locomotive engines. In order to withdraw the vessel from the direct line of tram-

way and place it on one side of the line, certain parts of the line have transverse framings, by which the cradle, with the vessel, may be moved in a lateral direction; and in order to raise the vessel from one level to another, temporary inclined planes are proposed to be constructed of iron, much in the same way as iron bridges.

These are all the features which appear to be considered by the Patentee as new, though he has, in his specification, given a very elaborate description of the invention, and exhibited it in various positions in several rudely executed landscapes. Enough, however, has been said to render the intention evident.—[*Inrolled in the Inrolment Office, June, 1831.*]

The specifications of some few of the inventions for which patents were granted in 1830, having, by accident, been omitted in their proper order of time, we have inserted them in this present volume, in fulfilment of our pledge to report every new invention for which a patent should be obtained.

Of the one hundred and eighty patents granted in England in that year, one hundred and seventy-five have been described in the pages of our journal; of the remaining five, no specifications have been inrolled in Chancery, therefore, these patents have become *null and void*.—ED.

BILL FOR REGULATING TOLLS PAYABLE BY STEAM-CARRIAGES.

WE are happy to inform our readers that the above Bill, referred to in our last number, has been rejected by the House of Lords, and we now give the Report of the Select Committee appointed by the Lords to investigate the matter and hear evidence thereon; and although we do not agree with the opinion expressed in their report, yet we congratulate our friends who are interested in steam locomotion, that the intended Bill has met with that fate anticipated in our last.

*Report of the Select Committee of the House of Lords (presented
by the Duke of Richmond) on tolls for steam-carriages.*

That the Committee have proceeded to the examination of witnesses, and have to report that the evidence of the principal engineers who have turned their attention to the construction of carriages impelled by steam upon the highways, proves that very considerable progress has been made towards their perfection, and that they can travel with great rapidity.

The noise and smoke attendant upon their use have been very materially diminished, but it has been shown in evidence that they still have the effect of terrifying horses, and that accidents have occurred in consequence. Much conflicting evidence has been tendered to the Committee as to the safest shape and proper limitation of the vessels for the generation of steam to be used in these carriages. All the witnesses, however, agree, that in whatever shape the boilers may be made, their size should be such that, in case of explosion, they would not endanger the safety of the public. And the Committee do not feel themselves at present competent to come to such a conclusion on these two important points as would enable them to recommend the necessary enactments.

No adequate means have as yet been provided to guard against the emission of sparks from the chimneys of the engines which

would guard effectually against the danger arising from them, although, with proper care in the selection and preparation of fuel, it does not appear that the danger is very imminent.

It also appears, by the evidence of some of the witnesses examined, that although the management of the carriages is by no means difficult, when under the superintendence of an experienced conductor, yet that they require much greater skill than is necessary in the management of locomotive engines upon railways; and to find persons properly qualified, might be a matter of considerable difficulty.

It is essential that the size and weight of the carriages to be employed should be regulated, so as to prevent their being of that weight and size as to prove destructive to the roads, and serious nuisance to the public.

It appears, also, that the tolls intended to be imposed by the bill on the subject, are calculated upon an erroneous view of the power of a horse; the rate of toll is calculated upon by a supposition, that each horse is able to draw a ton weight; whereas, it is shown that a horse at a rapid pace cannot, upon ordinary roads, draw more than half that weight.

The Committee entertain serious objections to the Bill referred to them; and they are not of opinion that these objections are counterbalanced by the prospect of any great public advantage. The evidence, on the contrary, proves that the proposed mode of conveyance can only be applied to passengers; and it appears that some experienced engineers, after a careful examination of the expenses attendant upon it, have been induced to abandon all hopes of its success as a profitable undertaking.

It is probable, therefore, that any encouragement on the part of the Legislature would only give rise to wild speculations, ruinous to those engaging in them, and to experiments dangerous to the public. The Committee, therefore, recommend that the Bill should not at present be proceeded with; at the same time, they have no doubt that the further imposition of prohibiting tolls in local acts is not a desirable mode of legislation upon such a subject.

SCIENTIFIC NOTICES.

 (Continued from p. 386.)

PARIS.—IRON RAIL-ROAD FROM PARIS TO ST. GERMAIN.

We are informed that the anonymous society which has undertaken this line of rail-road, consists of MM. Rothschild, brothers, J. C. Davilliers and Co., and several other eminent names. M. E. Pereire, in the capacity of acting director, will superintend the execution of the determinations of the board of administration of the Society. The execution of the works, and of the machines to be employed, is intrusted to three engineers. The capital consists of five millions of francs (200,000*l.*), divided into ten thousand shares.—*An. de la Société Polytechnique*, No. 17. p. 151.

GAS-LIGHTS.

It is stated that the lighting of the Triumphal Arch de l'Etoile (Champs Elysée) of the Prefecture of the Police, and of the Mint, will be shortly effected by means of *portative gas, uncompressed*. This mode will exclude the necessity of laying subterraneous gas-pipes: it has been for some years past adopted in the city of Rheims. The discovery of uncompressed gas is attributed to M. Houzeau-Nuiron, our distinguished chemist.—*Ibid.*

LIQUIFIED CARBONIC ACID.

We are indebted to M. Thilorier for the discovery of the process by which this acid may be obtained in quantities in a very few moments. By means of his apparatus, he obtains, from chemical combination, a litre (quart) of liquified carbonic acid in a short space of time; and he has already studied its principal properties, which had engaged the attention of M. Faraday, who obtained it only in small quantities. It is the substance of all others, not excepting carbonated hydrogen gas, which expands and contracts to the greatest degree: this property may become the powerful instrument of effecting great changes in our machi-

nery and motive principles, as it is infinitely more effective and economical than any based upon the evaporation and condensation of fixed liquids, such as steam from water.

Another singular property of this new agent, is the excessive degree of cold produced by the sudden evaporation or volatilization of the acid, the temperature becomes lowered to 95° below zero of the centigrade thermometer; and M. Thilorier, who has obtained this result, expects to be able to reduce the temperature below 150° under zero. This property of the liquified acid may become of the highest importance in numberless processes of the arts and sciences.—*Ibid.* p. 152.

EUROPE.

The atmosphere of Europe is more highly and generally charged with electric fluid than any other portion of the globe; storms and hail are here more frequent than in any other quarter. The highest point of Europe is about 17,000 feet (French) above the level of the sea; that of America is 20,000 feet; and that of Asia, 25,000 feet. The mountains of Europe contain vast masses of water, which tend to the advantages of commerce, by means of six hundred navigable rivers. About two-thirds of the surface of Europe are applicable to the purposes of cultivation and vegetable production: in this respect it is nearly on a par with America, and has the advantage of Asia and of Africa; in the latter portion of the globe, only one-third of the soil is capable of cultivation; but as to the *power of vegetation*, Europe is inferior to the other quarters. Lemons, oranges, olives, and rice, may be cultivated to the 43° of latitude; the vine to the 50° ; wheat, and the most valuable commercial products—such as flax, hemp, and tobacco, and fruit trees generally, may be cultivated to the 60° ; at 62° , plum trees, hemp, hops, the cole genus, the oak, poplar, &c. cease to prosper. Up to the 70° of latitude, pines, firs, rye, oats, mosses, and common grasses may be found. As to animals, fine breeds of horses will not be found beyond 55° , nor hogs beyond 60° . The precious metals are to be found in the south of Europe; almost every other metal and mineral in the northern parts.

RAILROAD CARRIAGES.

The Academie des Sciences of Lyons have offered a prize, consisting of a gold medal of the value of 300 francs, to any person who could answer the following question:—"What are the modifications necessary in the construction of carriages employed on railroads, or in the disposition of the rails to diminish friction, and allow the carriages to run upon a road slightly curved with great velocity?" The prize has been adjudged to M. Alexandre Fournet, civil engineer. The means which he adopts are as follows:—The wheels of his carriages move in the direction which is given to them by the curved road upon which they run. They follow one after the other, and are attached to each other by the axletrees, the ends of the axles being connected together by rods. The felly of the wheel presents a deep channel, the edges of which embrace the rail.

THE NUMBER OF STEAM-ENGINES IN USE IN BELGIUM, IN COMPARISON WITH THOSE EMPLOYED IN FRANCE.

There are at the present time in action in the province of Liege 216 steam-engines, producing altogether the united power of 5446 horses. Of these 216 machines, there are 139 on the right side of the river Meuse, and producing a power equal to 2176 horses, and 79 on the left side of this river of the aggregate power of 3269 horses. Of the whole number of engines, there are only three of foreign manufacture. The most powerful is one of 300 horse power, and the weakest is of $1\frac{1}{2}$ horse power.

In France, there is no engine exceeding 100 horse power. In the province of Liege there are eighteen engines of from 100 to 300 horse power; 20 from 50 to 100; 38 from 20 to 50; 139 from 5 to 20; and 1 of $1\frac{1}{2}$ horse power. If the power of the engines in the province of Liege be added to that of the other Belgic provinces, the total amount of steam power will equal that exerted by 20,000 horses. It is principally at Charleroi and in its vicinity that the most powerful engines are found.

According to the notice published by the administration of bridges and roads in France, the united power of the 946 engines

in that kingdom, only amounts to a force equal to that exerted by 14,051 horses. The united power of the Belgic ones, according to this statement, then surpasses the aggregate power of all the steam-engines in France.

In comparing the respective population of the two countries, we find, according to this report, that the industry of the Belgians is twelve times more developed *than that of the French.*—*Recueil Industriel.*

EMPLOYMENT OF HOT AIR AS A MOVER, INSTEAD OF STEAM, PROPOSED BY M. BURDIN, CHIEF ENGINEER OF THE MINES.

The author considers that he can, with very great advantage, use compressed hot air instead of steam as a moving power. He supposes that atmospheric air at zero, and with a pressure of four atmospheres, will be forced, by means of a forcing pump, into a plate iron cylinder, furnished with bricks in the interior, for the purpose of preserving the heat and shutting in the furnace, covered with a layer of coal, sufficient to convert half the oxygen of the air into carbonic acid. This air thus acquires a temperature of 800° at least, and quadruples the volume without diminishing the pressure. He will then be able to produce, with the aid of two pistons, which he works by turns, a power much superior to that which was necessary for the introduction of the air, that is to say, at least double.

M. Burdin, in calculating all its effects, demonstrates that one kilogramme (about 2lbs.) of coal will produce, in this case, a force represented by 598,600 kilogrammes raised to six or seven times the real force of the best steam-engines constructed by Woolf. This advantage partly proves that, in the hot-air apparatus, the caloric disengaged by the combustible materials is entirely employed to the effect proposed; whilst in the boilers of steam-engines, one-half of the heat escapes by the chimney, and does not fulfil the proposed end of heating.—*Bulletin de la Société d'Encouragement.*

In a note under this notice, the Editor of the Bulletin says that the Society does not warrant the advantages of the machines

or instrument, nor the success of apparatus which appear in these notices; and that as this machine is only in contemplation, time and experience alone can pronounce judgment upon its advantages.

CONSUMPTION OF COAL IN STEAM-ENGINES.

Mr. Taylor stated, that the work done in the best engines now employed in Cornwall, by the consumption of one bushel of coal, required, ten or twelve years ago, the consumption of two bushels; that during the period of Bolton and Watt's patent, four bushels were consumed to do the same work; and that, in the earlier stages of the employment of steam power, the quantity of coal used was sixteen bushels. The steam-engines now at work in the mines of Cornwall, are equal in power to at least 44,000 horses.

CONTINENTAL RAILWAYS.

A Brussels journal says, "We may now go to Antwerp in one hour. Shortly, we shall be able to reach Paris in six hours, Berlin in sixteen, and St. Petersburg in sixty. If it were possible to make a journey round the world on a continuous railroad, it would be accomplished in six weeks."

SUBSTITUTE FOR HOPS.

An inhabitant of Chatalet, Department du Nord, is said to have discovered that egg-shells may be used as a substitute for hops in brewing beer.—*Morning Herald.*

FRANKFORT.

A communication has been made to the Society of Natural Sciences in this city, of the discovery of a new motive power, created by means of a galvanic battery. This discovery, it is calculated, may supersede the use of steam; it is stated to be more powerful, much less expensive, and less dangerous than steam.

CULTURE OF THE POTATOE.

A practical farmer, in the neighbourhood of Haddington, has ascertained, that in growing potatoes a great advantage may be

derived by plucking off the bloom from the stem, which practice prevents the ripening of the heavy crop of seed-apples, and produces an increase of at least 14 per cent. in the produce of the potatoes.—*Agriculturist.*

List of Patents

Granted in Scotland from 21st June to 21st July, 1836.

- To John Woolrick, of Birmingham, professor of chemistry, for certain improvements in producing or making the substance commonly called or known by the name of carbonate of baryta, or carbonate of barytes.—21st June.
- William Taylor, of Southwark, and Henry Davies, of Stoke Prior, both engineers, for certain improvements in machinery or apparatus for introducing water or other fluids into steam-boilers or evaporating vessels; also for obtaining mechanical power by the aid of steam, and for communicating motion to vessels floating in water.—27th June.
- John Wilde, late of New York, now in Manchester, merchant, and Joseph Whitworth, of Manchester, engineer, partly communicated to them by foreigners residing abroad, for certain machinery for effecting the operation called knitting, and producing a fabric similar to that of knitted stockings.—29th June.
- David Fisher, of Wolverhampton, mechanic, for an improvement in steam-engines.—7th July.
- Hamer Stansfield, of Leeds, merchant, communicated to him by Christian William Schonherr, of Schneeberg, Saxony, for improvements in machinery for preparing certain threads or yarns, and for weaving certain fabrics.—8th July.
- Thomas Hock Shute, of Watford, silk throwster, for improvements in spinning and doubling organzine silk.—8th July.
- Robert Walter Kimburne, of South Shields, agent, for certain improvements in the manufacture of plate glass.—12th July.

- To Edward Jelowicki, of 8, Seymour-place, Bryanstone-square, London, communicated by a foreigner residing abroad, for certain improvements in steam-engines.—15th July.
- Benjamin Simmons, of Winchester-street, Southwark, engineer, for improvements in chemical retorts, stills, and other apparatus, and in the machinery connected therewith, and by the use or employment thereof, various processes can be speedily, conveniently, and economically performed.—18th July.
- John Isaac Hawkins, of Chase Cottage, Pancras Vale, Hampstead-road, London, engineer, communicated by a foreigner residing abroad, for an improvement in the art of manufacturing iron and steel.—18th July.
- John Archibald, manufacturer, Alos, Stirlingshire, for certain improvements in machinery or apparatus for carding wool, and doffing, strengthening, piecing, roving, and drawing rolls or cardings of wool.—21st July.
- William Wainwright Potts, of Burslem, Staffordshire, china and earthenware manufacturer, William Machin, china manufacturer, of Burslem, aforesaid, and William Bourne, also of Burslem, manager, for an improved method or process whereby impressions or patterns in one or more colours or metallic preparations are produced, and transferred to surfaces of metal, wood, cloth, paper, papier-machée, bone, slate, marble, and other suitable substances, prepared or otherwise, not being used or known as earthenware, porcelain, china, glass, or other similar substances.—29th July.
- Walter Hancock, of Stratford, engineer, for an improvement or improvements upon steam-engines.—29th July.
- John Macdowall, of Johnstone, Renfrewshire, engineer, for certain improvements in machinery for sawing and cutting, and likewise in the mode of applying motive power thereto.—2nd August.
- Henry Walker Wood, 29, Austin-friars, London, merchant, for certain improvements in certain locomotive apparatus.—4th August.
- John Burns Smith, of Salford, spinner, and John Smith,

of Halifax, dyer, for a certain method or methods of tentering, stretching, or keeping out cloth to its width, made either of cotton, silk, wool, or any other fibrous substances, by machinery.—11th August.

To Henry Gore, of Manchester, machine-maker, for certain improvements in the machinery or apparatus for spinning or twisting cotton and other fibrous substances.—11th August.

— Samuel Hall, of Basford, for improvements in propelling vessels ; also improvements in steam-engines, and in the method or methods of working some parts thereof, some of which improvements are applicable to other useful purposes.—15th August.

— Thomas Earl of Dundonald, of Regent's-park, London, for improvements in machinery or apparatus applicable to purposes of locomotion.—15th August.

— Joshua Bates, of Bishopsgate-street, London, merchant, in consequence of a communication made to him by a foreigner residing abroad, for certain improvements in machinery for cleaning and preparing wool.—19th August.

New Patents

SEALED IN ENGLAND,

August, 1836.

To Nathau Bailey, of Leicester, in the county of Leicester, framesmith, for his invention of certain improvements in, or additions to, machinery for manufacturing stocking fabric.—Sealed 1st August—6 months for inrolment.

To John Thomas Betts, of Smithfield Bars, in the city of London, rectifyer, for improvements in the process of preparing spirituous liquors in the making of

brandy, being a communication from a foreigner residing abroad.—Sealed 3rd August—6 months for enrolment.

To Webster Flockton, of the Spa-road, Bermondsey, in the county of Surrey, turpentine and tar distiller, for his invention of certain improvements in preserving timber.—Sealed 3rd August—6 months for enrolment.

To John Archibald, of the parish of Alva, in the county of Stirling, in the kingdom of Scotland, manufacturer, for his invention of certain improvements in machinery or apparatus for carding wool, and dosing, straightening, piecing, roving, and drawing rolls or cardings of wool.—Sealed 6th August—6 months for enrolment.

To Ramsay Richard Reinagle, of Albany-street, Regent's-park, in the county of Middlesex, Esq., for his invention of improvements in the construction of carriages for the conveyance of persons and goods, or merchandise.—Sealed 6th August—6 months for enrolment.

To Thomas Binns, of Mornington-place, in the Hampstead-road, in the county of Middlesex, civil engineer, for his invention of improvements in railways, and in the steam-engines to be used thereon and for other purposes.—Sealed 6th August—6 months for enrolment.

To Thomas John Fuller, of the Commercial-road, Limehouse, in the county of Middlesex, civil engineer, for his invention of a new or improved screen for intercepting or stopping the radiant heat arising or proceeding from the boilers and cylinders of steam-engines.—Sealed 9th August—6 months for enrolment.

To John Burns Smith, of Salford, in the county of

Lancaster, spinner, and John Smith, of Halifax, in the county of York, dyer, for their invention of a certain method or methods of tentering, stretching, or keeping out cloth to its width, made either of cotton, silk, wool, or any other fibrous substances, by machinery.—Sealed 10th August—6 months for enrolment.

To Henry Pershouse Parkes, of Dudley, in the county of Worcester, iron merchant, for his invention of improvements in flat pit chains.—Sealed 11th August—6 months for enrolment.

To Joseph Douglass, of Morpeth, in the county of Northumberland, rope maker, for his invention of improvements in the manufacture of oakum.—Sealed 11th August—2 months for enrolment.

To Edward Light, of Royal-street, Lambeth, in the county of Surrey, civil engineer, for his invention of certain improvements in propelling vessels and other floating bodies.—Sealed 11th August—6 months for enrolment.

To William Newton, of the Office for Patents, Chancery-lane, in the county of Middlesex, for improvements in the means of producing instantaneous ignition, being a communication from a foreigner residing abroad.—Sealed 11th August—6 months for enrolment.

To Robert Allen Hurlock, of Whaddon, in the County of Cambridge, clerk, for his invention of improvements in axletrees.—Sealed 11th August—2 months for enrolment.

To Joshua Butters Bacon, of Regent-square, in the county of Middlesex, gentleman, for improvements in the structure and combination of certain apparatus employed in the generation and use of steam.—Sealed 13th August—6 months for enrolment.

To Thomas Gauntley, of the town and county of the town of Nottingham, mechanic, for his invention of certain improvements in machinery for making lace and other fabrics, commonly called warp machinery.—Sealed 15th August—6 months for enrolment.

To George Leech, of 25, Norfolk-street, in the parish of Islington, in the county of Middlesex, carpenter, for his invention of a certain improved method of connecting window sashes and shutters, such as are usually hung and balanced by lines and counter weights with the lines by which they are so hung.—Sealed 15th August—6 months for enrolment.

To William Fothergill Cooke, of Bellayse College, in the county of Durham, Esq., for his invention of improvements in winding up springs to produce continuous motion, applicable to various purposes.—Sealed 17th August—6 months for enrolment.

To Joseph Hall, of Margaret-street, Cavendish-square, in the county of Middlesex, plumber, for his invention of improvements in the manufacture of salt.—Sealed 17th August—2 months for enrolment.

To Francois de Tausch, of Percy-street, Bedford-square, in the county of Middlesex, military engineer to the King of Bavaria, for his invention of improvements in apparatus or machinery for propelling of vessels for raising water, and for various other purposes.—Sealed 25th August—6 months for enrolment.

CELESTIAL PHENOMENA, FOR SEPTEMBER, 1836.

D. H. M.		D. H. M.	
1	Clock after the ☉ 9m. 14s.	17	Pallas R. A. 20h. 41m. dec. 5. 14. N.
—	☽ rises 9h. 3m. A.	—	Ceres R. A. 23h. 24m. dec. 21. 6. S.
—	☽ passes mer. 4h. 22m. M.	—	Jupiter R. A. 8h. 49m. dec. 18. 15. N.
—	☽ sets 0h. 18m. A.	—	Saturn R. A. 14h. 0m. dec. 10. 25. S.
—	Occul. A Tauri, im. 16h. 54m., em. 18h. 11m.	—	Georg. R. A. 22h. 15m. dec. 11. 37. S.
2 11 48	☽ in ☐ or last quarter.	—	♃ passes mer. 1h. 20m.
4 13	☽ in Apogee.	—	♀ passes mer. 20h. 59m.
21 51	♃ in the descending node.	—	♂ passes mer. 19h. 30m.
23 47	♂ in conj. with the ☽ diff. of dec. 3. 49. S.	—	♃ passes mer. 21h. 1m.
5	Clock after the ☉ 1m. 31s.	18 4 19	☽ in ☐ or first quarter.
—	☽ rises 11h. 35m. A.	15 47	♀ in conj. with ♃ diff. of dec. 3. 36. S.
—	☽ passes mer. 7h. 39m. M.	19 20	☽ in Perigee.
—	☽ sets 4h. 35m. A.	—	Clock after the ☉ 6m. 42s.
10	♀ in conj. with the ☽ diff. of dec. 9. 43. S.	—	☽ rises 4h. 46m. A.
7 5 2	♃ in conj. with the ☽ diff. of dec. 4. 46. S.	—	☽ passes mer. 8h. 29m. A.
13 16	Ceres in oppo. ☉ intens. of light 0,678.	—	☽ sets morn.
10	Clock after the ☉ 3m. 12s:	—	Occul. Capri, im. 5h 25m., em. 6h. 29m.
—	☽ rises 4h. 22m. M.	15 32	♃'s first sat. will im.
—	☽ passes mer. 11h. 40m. M.	22 4 57	♃ in conj. with the ☽ diff. of dec. 4. 23. N.
—	☽ sets 6h. 40m. A.	12 37	☉ enters Libra, Autumn commences.
11 0 43	Ecliptic conj. or ☉ new moon.	24 11 48	Ecliptic oppo. or ☉ full moon.
12 5 43	♃ in conj. with the ☽ diff. of dec. 3. 57. S.	16	♃'s second satt. will im.
16 36	♃'s fourth sat. will em.	25	Clock after the ☉ 8m. 26s.
13 22 11	♃ in conj. with the ☽ diff. of dec. 1. 33. N.	—	☽ rises 6h. 21m. A.
15 1 13	♃ in Aphelion.	—	☽ passes mer. morn.
17	Mercury R. A. 10h. 4m. dec. 13. 40. N.	—	☽ sets 6h. 23m. M.
—	Venus R. A. 8h. 45m. dec. 14. 44. N.	26 23 27	♃ greatest elong. 25. 46. E.
—	Mars R. A. 7h. 17m. dec. 22. 57. N.	30	Clock after the ☉ 10m. 6s.
—	Vesta R. A. 14h. 19m. dec. 9 27. S.	—	☽ rises 7h. 55m. A.
—	Juno R. A. 11h. 24m. dec. 3. 28. N.	—	☽ passes mer. 3h. 49m. M.
		—	☽ sets 0h. 26m. A.

METEOROLOGICAL JOURNAL,

FOR JULY AND AUGUST, 1836.

1836.	Thermo.		Barometer.		Rain in in- ches.	1836.	Thermo.		Barometer.		Rain in in- ches
	Hig.	Low.	Hig.	Low.			Hig.	Low.	Hig.	Low.	
July						Aug.					
26	69	53	30,02	29,99	,025	10	72	42	30,11	30,10	
27	73	57	30,05	30,03		11	71	49	30,24	30,20	
28	77	50	30,00	29,90		12	71	53	30,25	30,21	
29	63	57	29,66	29,55	,175	13	75	47	30,16	30,00	
30	64	52	30,12	29,81	,1	14	73	54	29,86	29,82	,025
31	68	47	30,40	30,26	,025	15	69	53	29,96	29,82	,075
Aug.						16	70	51	30,06	30,01	
1	68	50	30,10	29,95	,0125	17	74	56	30,01	29,99	
2	67	47	29,99	29,94		18	73	48	29,98	29,86	
3	75	52	29,96	29,76		19	69	53	30,07	30,03	,025
4	71	53	29,83	29,76		20	63	44	29,91	29,56	
5	72	56	29,95	29,89		21	64	44	29,85	29,81	,05
6	67	54	30,06	30,02		22	67	47	29,74	29,62	
7	70	46	30,11	Staty.		23	61	53	29,64	29,54	,05
8	72	50	30,09	30,08		24	61	47	30,05	29,83	,875
9	69	44	30,11	Staty.		25	66	43	30,07	29,98	

Edmonton.

CHARLES HENRY ADAMS.

Latitude 51° 37 32 N.

Longitude 3 51 West of Greenwich.

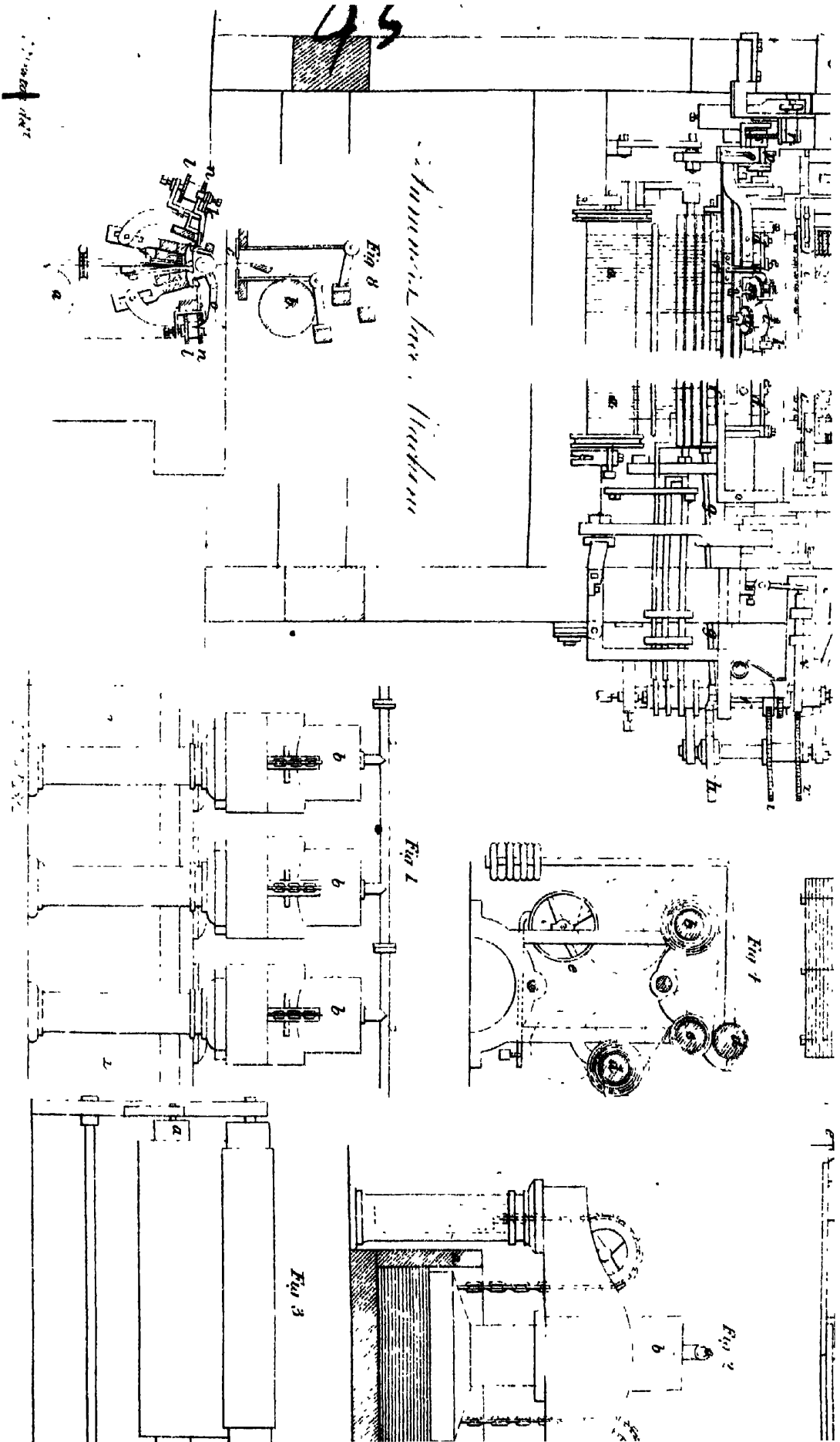

THE
London
JOURNAL OF ARTS AND SCIENCES.

No. XLV.

[SECOND SERIES.]

Recent Patents.

To SAMUEL ROSCOE BAKEWELL, of Whiskin Street, in the parish of St. James, Clerkenwell, in the county of Middlesex, brick and stone ware manufacturer, in consequence of communications made to him from certain foreigners residing abroad, and subsequent improvements made by himself, for an invention of certain improvements in machinery, apparatus, or implements to be used in the manufacture of bricks, tiles, and other articles, to be formed or made of clay or other plastic materials; parts of which said machinery are also applicable to other useful purposes.—[Sealed 18th August, 1830.]

THESE improvements may be arranged under three heads; first, in the machinery or apparatus for grinding the clay

and other materials for making bricks, tiles, &c.; second, in the contrivance of a press for the purpose of squeezing or compressing the bricks, when partially dried into a more solid and compact state than bricks of the ordinary kind; and third, in a peculiarly constructed hand mould, in which the bricks are to be formed. The particulars of which the Patentee has set out in the following description, referring to the figures shewn in Plate VII.

Fig. 1st is a section and elevation, and fig. 2, a plan of a machine, for mixing, grinding and tempering clay or other plastic substances, so as to prepare and render them fit to be applied to the forming or making of bricks, tiles, cornices, copings, &c., and also for the grinding, mixing, and tempering sand, lime, chalk, barilla, and for various other useful purposes, part only of the circular pit being shewn; *a, b*, represent the edge or border of the pit, which may be from thirty to forty feet in diameter, and from nine to eighteen inches in depth. A circular platform or mound *l*, being formed in the centre from twelve to sixteen feet in diameter; *c, c*, is a wheel, which may be from six to nine feet in diameter, and from three to nine inches broad on its rim; the rim of this wheel must be made to come into contact with the bottom of the pit *n, n*; the wheel may be made to traverse from *a*, to *b*, and *b*, to *a*, by placing the arm *d, d*, in various situations, varying from a radius line, or a line pointing to the centre of the pit, and which may be effected in different modes, namely, by turning the pinion *g*, by means of its handle or winch, so as to cause the metal tooth arc *i, i, i*, to bring the arm connected with it, and which moves upon the pin *m*, into such a position as is shewn by the dotted lines in fig. 2, the pinion being prevented from moving, by means of a peg placed in one of the holes formed in the circular plate *o*. to

receive it, and which acts against the winch or handle of the pinion *g*.

The wheel *c, c*, is made to traverse in the contrary direction, by changing the position of the arm *d, d*, accordingly from *h*, to *k*; *e, e*, and *f', f*, are supporting wheels to keep the shaft *d, d*, from bending, but which, however, may occasionally be dispensed with. The clay or other materials spread all over the circular pit, will thus be mixed, ground, or tempered by the repeated action of the wheel *c, c*, in spiral courses passing over them.

The top of the circular mound or platform *l*, in the centre of the pit, is made perfectly flat, for the wheel *f', f*, to travel on, and a square hole or pit is made in the centre of it, to receive the post and frame *j, j, j*, which supports the arm *d, d*; *m, m*, are the branches of the yoke, to which horses or other animals are to be affixed, in order to actuate the machine, although it may also be turned by other powers, such as steam, water, or wind, if found desirable. A counterbalance or weight, as shewn in *fig. 1*, may be hung upon the shorter end of the arm *d, d*, to steady it; and the spindle *p*, at the end of it must be made cylindrical, and of a sufficient length to allow of it rising or falling in the post and frame *j, j*, according to the greater or lesser quantity of clay or other materials to be spread in the circular pit, in order to be operated upon. *Fig. 2**, is an end view, the different parts being indicated by the same letters of reference as in *fig. 1*.

Fig. 3, is another method of varying the position of the arm *d, d*, where, instead of the toothed arc, and pinion before described, two small windlasses *g, g*, shewn in *fig. 3**, are mounted upon the upper part of a metal frame *i, i*, and around the barrels of which said windlasses,

ropes or chains, may be coiled and uncoiled by means of a winch or handle applied upon the axis of the windlasses, and which said ropes or chains being affixed to the arm d, d , the windlasses may be kept in their required position, by means of pegs being inserted into the rings of holes provided for the purpose, as shewn in fig. 3*, and as before mentioned.

Another mode of causing the wheel c , to traverse over the whole extent of the pit a, b , in circles instead of spirals, as above described, is shewn in elevation in fig. 4, in plan in fig. 5; and endways in fig. 4*; in which figures, a toothed metal rack is shewn, as affixed upon the upper surface of the arm d, d , into which a pinion acts, which is mounted upon an axis, working in holes formed to receive it in the metal frame, which is mounted upon the top of the upright cylindrical stem p , and by means of a winch or handle affixed upon the said axis, the pinion may be turned a little at each revolution of the wheel c , around the pit, in order to cause it to run in fresh circular paths; or instead of a rack and pinion, two barrels q, q , may be employed turning upon axes, working in holes formed in the upper part of the metal frame, with squared parts at their ends to receive a handle or winch; and around these barrels cords or chains may be applied, which are likewise affixed to two studs or pins, driven or otherwise secured into the upper surface of the arm d, d , and which cords pass underneath two loose barrels q, q , also turning on an axis mounted in the said frame, and thus by turning either of the two uppermost barrels a little at each revolution of the wheel c , the cords or chains will move the arm d, d , within the metal frame a sufficient quantity to cause the wheel c , to move continually in fresh circles. Two friction rollers are mounted in the lower part of the metal frame, to assist the motion

of the arm *d, d*, and a supporting roller mounted in a proper frame, may be also applied, as shewn in fig. 4, to run upon the level surface of the central platform or mound, and instead of one wheel *c*, only, two or more may be employed, and these also on each side of the mound or platform, if thought necessary.

Fig. 6, represents another mode of effecting the latter object ; here a female screw is formed in a wood or metal head, which is affixed upon the top of the cylindrical spindle *p*, and a corresponding screw is made upon the arm *d, d*, which can be turned a little at each revolution of the wheel *c, c*, around the pit, by means of a pin or lever inserted into either of the holes, formed through the screw to receive it.

Figure 7, exhibits an arm *d, d*, mounted upon the top of the spindle *p*, which has a cylindrical stem and shoulder formed upon it, the cylindrical part being passed through a hole formed to receive it, in the centre of the arm *d, d*; this arm has a right and left threaded screw, upon which female right and left threaded screws, made in sockets, naves or boxes, fitted into the centres of the wheels *c, c*, act ; and thus cause those wheels to run in spiral courses over the whole extent of the circular pit. It being however necessary to reverse the motion of the arm, to cause them to move in the contrary direction, other modes may also be employed to produce a backward and forward lateral movement of the wheel *c, c*, such, for instance, as the well known mangle motion ; namely, by affixing a windlass, barrel or wheel, upon the moveable head, upon which a chain, strap, or rope may be wound and unwound, by means of a winch or handle applied upon the axis of the windlass or barrel. The arm *d*, may be prevented from rising too high, by affix-

ropes or chains, may be coiled and uncoiled by means of a winch or handle applied upon the axis of the windlasses, and which said ropes or chains being affixed to the arm *d, d*, the windlasses may be kept in their required position, by means of pegs being inserted into the rings of holes provided for the purpose, as shewn in fig. 3*, and as before mentioned.

Another mode of causing the wheel *c*, to traverse over the whole extent of the pit *a, b*, in circles instead of spirals, as above described, is shewn in elevation in fig. 4, in plan in fig. 5; and endways in fig. 4*; in which figures, a toothed metal rack is shewn, as affixed upon the upper surface of the arm *d, d*, into which a pinion acts, which is mounted upon an axis, working in holes formed to receive it in the metal frame, which is mounted upon the top of the upright cylindrical stem *p*, and by means of a winch or handle affixed upon the said axis, the pinion may be turned a little at each revolution of the wheel *c*, around the pit, in order to cause it to run in fresh circular paths; or instead of a rack and pinion, two barrels *q, q*, may be employed turning upon axes, working in holes formed in the upper part of the metal frame, with squared parts at their ends to receive a handle or winch; and around these barrels cords or chains may be applied, which are likewise affixed to two studs or pins, driven or otherwise secured into the upper surface of the arm *d, d*, and which cords pass underneath two loose barrels *q, q*, also turning on an axis mounted in the said frame, and thus by turning either of the two uppermost barrels a little at each revolution of the wheel *c*, the cords or chains will move the arm *d, d*, within the metal frame a sufficient quantity to cause the wheel *c*, to move continually in fresh circles. Two friction rollers are mounted in the lower part of the metal frame, to assist the motion

of the arm d, d , and a supporting roller mounted in a proper frame, may be also applied, as shewn in fig. 4, to run upon the level surface of the central platform or mound, and instead of one wheel c , only, two or more may be employed, and these also on each side of the mound or platform, if thought necessary.

Fig. 6, represents another mode of effecting the latter object ; here a female screw is formed in a wood or metal head, which is affixed upon the top of the cylindrical spindle p , and a corresponding screw is made upon the arm d, d , which can be turned a little at each revolution of the wheel c, c , around the pit, by means of a pin or lever inserted into either of the holes, formed through the screw to receive it.

Figure 7, exhibits an arm d, d , mounted upon the top of the spindle p , which has a cylindrical stem and shoulder formed upon it, the cylindrical part being passed through a hole formed to receive it, in the centre of the arm d, d ; this arm has a right and left threaded screw, upon which female right and left threaded screws, made in sockets, naves or boxes, fitted into the centres of the wheels c, c , act ; and thus cause those wheels to run in spiral courses over the whole extent of the circular pit. It being however necessary to reverse the motion of the arm, to cause them to move in the contrary direction, other modes may also be employed to produce a backward and forward lateral movement of the wheel c, c , such, for instance, as the well known mangle motion ; namely, by affixing a windlass, barrel or wheel, upon the moveable head, upon which a chain, strap, or rope may be wound and unwound, by means of a winch or handle applied upon the axis of the windlass or barrel. The arm d , may be prevented from rising too high, by affix-

ing a screwed nut upon the top of the spindle *p*, as shewn in fig. 7, or upon the lower end of it, as shewn in fig. 3.

Having thus described various machines for mixing, grinding, and tempering the materials, the Specification next proceeds to describe various machines for forming or pressing bricks, tiles, &c. when in a partly dried state.

Fig. 8, is an external elevation or side view of such a machine; figs. 9, and 10, two internal views of it, in different situations; and fig. 11, a plan or top view of it, in all of which figures, the same letters of reference indicate the similar parts of the machine; *a, a*, &c. is the wooden or cast iron frame of the machine; *b, b*, the sides of the mould; *c*, the swinging frame, for keeping down or removing the upper part of the mould; this frame is mounted upon a strong axis *d*, which moves in bearings formed in the lower ends of the swinging frame *c*, on the ends of the pivots of the axis *d*, and these must be screwed nuts, to keep the swinging frame steady on the same; *e*, the main lever united to, or affixed firmly to the axis *d*; *f, f*, two side links, which connect the main lever *e*, with a shorter lever *g*, affixed upon another axis *h*, shewn in fig. 11*, which turns in bearings or eye bolts affixed in the end of the frame.

Upon a square, formed on the end of the axis *h*, a hand lever *j*, fig. 8, is affixed, in order to actuate the apparatus, as will be hereafter described; *k, k*, are two webs affixed upon the axis *d*, to keep it in its place within the gaps formed to receive it on each side, within the lower side rails of the frame *a*; *l*, is a short lever, affixed upon the axis *d*, the use of which is to raise the stem *m*, of the piston *n*, which forms the bottom of the mould, when the hand lever *j*, is brought into the position shewn in fig. 8, and by the dotted lines in fig. 9, in order to compress the brick in the mould.

When this has been effected, the cover of the mould *c*, is to be thrown aside; the hand lever *j*, is then to be brought into the position shewn by the dotted lines in fig. 10; and the piston *n*, is to be farther elevated, so as to push the brick out of the mould in the following manner:—

In fig. 10*, at *o*, is shewn the necks or pivots, the ends of which turn in bearings affixed underneath the upper side bars of the frame *a*; *p*, is an arm or lever, affixed upon the axis *o*; to the end of which, the two links *q, q*, are jointed, and which are also jointed to the stem *m*, of the piston *n*. A hand lever *r*, is affixed upon a squared part, formed upon the outer end of the axis *o*, which rests in the position, shewn in figs. 8 and 9, whilst the brick is in the mould: but upon bringing it into the situation shewn by the dotted lines in fig. 10, it raises the piston *n*, and lifts the brick out of the mould, ready to be taken away.

The pressing of the brick in the mould is effected by bringing the hand lever *j*, into the position shewn in figs. 8 and 9, which depresses the levers *g*, and *e*, and raises the short lever *l*, which acts against and elevates the piston *n*, at the part *s*, of its stem, as shewn in figs. 8 and 9. The lower end of this piston stem is guided and steadied by means of five screws; three of which are passed through a strong cross bar *t*, one of them *u*, acting against the edge of the stem on one side, whilst the two others *v, v*, bring a back plate into contact with its opposite edge, two other screws *w, w*, fig. 11, also pass through the lower side rails of the frame, which act against the side of the stem.

In order to keep the piston *n*, steady whilst the brick is removed, the lever *r*, is to be lodged between two pins *x, y*, let into sockets and moveable at pleasure. The

lower one *x*, preventing the piston *n*, from rising too high, and the upper one keeping it steady. In figs. 8, 9, and 10, *z*, is another pin let into a socket in the side of the frame *a*, in order to limit the rise of the piston *n*, and thus to cause all the bricks to be made of an uniform thickness.

Across the upper plate *c*, of the mould, a strong cross bar is affixed by means of screws, and having holes at each end of it, through which the upper ends of the sides of the swinging frame *c*, are passed and secured by screwed nuts, above and below the cross bar, as shewn in fig. 8.

Figs. 12 and 13, are a front and side view of the piston *n*, and its stem *m*. Fig. 14, a plan of the axis *d*, and lever *e*, a side view of which is shewn in fig. 15; and fig. 16, is a plan of the axis *h*, with its lever *g*.

Fig. 17, is another press for bricks, in which the piston *n*, is raised and lowered by means of a toothed metal rack *c*, formed upon its stem *m*, into which a pinion *d*, acts, upon the axis of which a winch or handle may be affixed to turn it; and it has also a ratchet wheel *e*, affixed upon it, into the teeth of which a click, catch, or pall *f*, falls, in order to retain the piston in its position. A friction roller *g*, is placed at the back of the stem, to keep the rack *c*, in its place.

Fig. 18. represents another press for bricks, in which the movements of the piston *n*, in the mould are effected by means of two metal rods, one of which is shewn at *h*, in fig. 18, and which are jointed to the piston above; and to a stud or pin *i*, below, which is affixed in one of the arms of a wheel *i*, which has teeth formed partly around it, into which a pinion *d*, acts, when turned by means of a winch or handle, affixed upon its axis. A ratchet wheel *e*, with a click *f*, is also here provided, to

retain the pinion in its position. Fig. 19, is a plan or top view of the press shewn in fig. 17; and fig. 20, is another plan of the press exhibited in fig. 18.

In fig. 17, the top of the mould *c*, is closed by means of a metal plate dovetailed on its edges, and which slides in dovetailed grooves made in the sides *b, b*, of the mould to receive it. Fig. 19, shews the same in plan; in figs. 18, 20, 21, and 23, the top of the mould is shewn as closed, by means of a metal lid *c*, mounted either upon a rule joint hinge, or upon hinges on one side of it, and the other kept closed when in use, by means of a catch, either with or without a spring. Fig. 22, exhibits the top of the mould as opened.

For compressing curved tiles in the mould, the under side of the top of the mould must either be hollowed, or hollow blocks be introduced, as shewn in figs. 22, and 23; the top of the piston being also rounded to correspond therewith; or another rounded block be also introduced into the mould, as shewn in figs. 22 and 23.

Fig. 24, is a top view of a spring catch brick mould, intended to mould bricks by hand; and fig. 25, represents the same as opened; *a, a*, are the sides of the mould; a joint *b*, is made at one of its angles, extending the whole depth of the mould. Two angular ears, one of which is shewn at *d*, in both figures, are formed one upon the upper, and the other upon the lower edges of the end of the moveable part of the mould; and are passed through corresponding slits or holes, formed to receive them in the counter part of the mould, and thus to keep the sides steady. The end *c*, being also received into another gap made inside of the mould, a spring catch is affixed by screws upon the outside of the end of the mould (between the ears) which passes through a square hole made to receive it, in the corresponding side of the

mould, and hooks itself fast when the mould is shut, but can be readily released, by pulling the spring catch back.

Having thus shewn and described various modes of carrying these inventions into effect, the Patentee lastly declares that he does not mean or intend hereby to claim as his improvement, any of the various parts which may have been already known or in use, but only in combination; nor does he mean to claim the mode of grinding clay or other materials, or mixing, or tempering them in mills, by means of large stones employed as wheels, where they always run in the same circle or track; but he does hereby claim the power of causing them either to run in spiral paths, or in circular ones, continually varying in their diameter, until the materials spread over the whole bottom of the pit shall have been repeatedly operated upon. The Patentee says he has seen in Lancashire, in several of the potteries, stones of four or five feet in diameter, used in grinding or tempering clay, and revolving spirally, by the action of screwed shafts; but one end of which shafts rested on a wheel, and the other end supported upon a post in the centre of the floor, so that the stones were suspended upon the shaft at the height of two or three inches from the floor; and which said floor was merely a flat surface, without borders or forming a pit; whereas his wheels came into contact with the floor of the pit, excepting when the clay or other substances intervene, and raise them therefrom. The borders of the pit also confine the clay or other materials, and prevent them from spreading sideways, as in the ordinary methods. To the clay mills, or stones revolving on a screwed shaft, as above described, he has therefore no claim whatever. It may be well to observe that the bricks or balls of clay, previously to being

placed in the press must be in a half dried state, or in the same state as common bricks are taken, to be "smoothed or polished," and their external surface, or sides, ends and faces be rubbed with fine sand or dust (the latter of which is generally found in abundance in or near brick kilns), in order to prevent them from adhering to the moulds. It is also observed that this Patent is not for pressing bricks, tiles, cornices, &c. generally, but only for the particular description of presses that have been herein shewn and described.—
[*Inrolled in the Rolls, Chapel Office, February, 1831.*]

Specification drawn by Mr. Gill.

To SAMUEL HALL, of Basford, in the county of Nottingham, cotton manufacturer, for his having invented or found out a new method of, and apparatus for generating steam and various gasses to produce motive power.—[Sealed 31st May, 1828.]

THE intention of the Patentee is, to combine highly elastic airs with steam, for the purpose of working the piston of an engine constructed upon the principle of the single stroke atmospheric steam engine.

The very great advantage expected to result from this union of elastic air with steam as a motive power, induced us to withhold our report of this invention, until sufficient time had been afforded to the Patentee to bring his plans into effective operation; it does not however appear, that the anticipated advantages have yet been realized, whether from defects in the construction of the apparatus, or in the principles upon which it is founded, we are not informed; but, that a something is still wanting, appears evident, and that something we understand, the inventor is about to supply, under the protection of a new patent.

The invention specified under the above title, is divided into four heads; first, the construction and adaptation of an air cylinder, which is to be employed as a pump, to inject and condense a quantity of atmospheric air intended to be heated by passing through the furnace; second, the peculiar construction of generator from which the steam is to be evolved; third, the receiver, into which the steam and heated air is passed, previous to its admission into the working cylinder; and fourthly, the working cylinder itself, furnished with peculiar entrance, and exit valves for the admission, and discharge of the heated air and steam.

One of the objects proposed, is the superior combustion of the fuel in the furnace, promoted by the artificial atmosphere of condensed air, which causes it to give out a much greater degree of heat, than the same quantity of fuel would do under any other circumstances, and consequently effects an economy in its consumption.

The furnace is made within a cylindrical iron vessel of very considerable substance, in the solid parts of which, various tubes or channels are formed for the reception of the water intended to be evaporated into steam. These tubes or channels are all connected together by contorted passages at the top and bottom of the generator; and an aperture at bottom allows part of the steam to discharge itself into the furnace.

The piston of the pump by which the atmospheric air is forced into the furnace, is intended to be of about ten times the area of the piston in the working cylinder, in order that as the two pistons work together simultaneously, the former may throw in very large volumes and condense the atmospheric furnace within the generator, to a pressure of about a hundred and fifty pounds upon the square inch.

The steam and the heated air both pass into a vessel called a receiver, which is furnished with an inlet and outlet valve, and from them they proceed through the induction aperture, to the under side of the piston in the working cylinder, in the usual way.

The elastic force of the steam and vapours raise the piston until it has nearly reached the top, and then an eduction valve opening, allows the steam and vapour to escape, when the piston descends again in its cylinder, by the superincumbent pressure of the atmosphere, and thus the mechanical or motive power is obtained, as in other single stroke engines.

The upward stroke of the piston in the working steam cylinder, produces a downward stroke of the piston of the air cylinder, owing to their mutual connection to a vibrating beam, and the act of injecting a volume of air, into the furnace as above described, causes a similar volume to be forced therefrom into the receiver.

In the event of the air cylinder being no larger than the working steam cylinder, it is proposed to work the piston in the steam cylinder, by expansive steam and vapour, that is to shut the induction valve, and thereby cut off the supply of steam and vapour, when the piston has made about one tenth part of its upstroke, the remainder of the stroke being effected by the expansion.

These are the leading features proposed, in which it would appear that the effect of the increased elasticity of the condensed air, caused by heating it in the furnace, is the only additional power anticipated.

The Patentee has descanted upon the minor parts of the machinery at great length, in a most elaborate specification, and with numerous figures of the detached parts, and their susceptible variations in detail, but for the reasons before given, we do not think it necessary at

present to be more diffuse ; when the subsequent improvements are matured, and given to the public under the proposed new patent, we shall have much pleasure in laying before our readers the complete subject, with our views of its practical advantages.—[*Inrolled in the Petty Bag Office, November, 1828.*]

To JOHN JONES, of Leeds, in the county of York, brush maker, for his having invented or found out certain improvements in machinery or apparatus for dressing and finishing woollen cloths.—[Sealed 21st August, 1829.]

THE object of this invention, in the first instance, is to produce a more beautiful and permanent lustre on the faces of the finer descriptions of woollen cloths than is obtained by the ordinary process of dressing, by brushing and pressing, or by the operation commonly called roll boiling. There is also an apparatus to be attached to a gig mill, or brushing mill, for the purpose of keeping the cloth tightly distended, and preventing it from wrinkling while under the operation of the teasles or brushes.

The first of these objects is proposed to be effected, by pressing the surface of the cloth against a smooth firm surface, while the cloth is under the operation of boiling or steaming, which is described as done by the following means, (*viz.*) Applying to the surface of the cloth smooth polished plates, or sheets of copper, or smooth surfaces of wood.

The cloths are to be spread out, and tightly distended upon the smooth faces of these plates of metal, or surfaces of wood, and being immersed in hot water or steam,

are then to be submitted to very considerable pressure, and after being thus operated upon for a sufficient space of time, the face of the cloth will, by the pressure and the moist heat, acquire a smooth brilliant and soft surface, superior to that obtained by any other operation of dressing woollen cloths heretofore practised.

The Patentee proposes two methods of performing this operation; the first is by providing a large vat or flat vessel, about two yards wide and twenty-two yards long, which will afford a sufficient area to receive the end of cloth, (that is half the piece) extended upon its bottom. When the cloth has been smoothly spread in this vat, he places a sheet of polished copper plate of equal area, to the part upon the face of the cloth, then turning over the other end of the piece of cloth, on the reverse polished surface of the copper, he lays that smooth in like manner, and having repeated the same with a succession of pieces of cloth, and sheets of copper placed one upon another, until the vat is considered to have a sufficient charge, a flat surface of board or any other suitable material, is then lowered down upon the pile of cloth and plates, and a series of hydraulic presses brought to bear upon it, so as to give the pressure to the cloth required.

Plate IX, fig. 1, represents a portion of one of these vats *a, a*, with the hydraulic presses *b, b*, adapted thereto; fig. 2, is a transverse section of the same, shewing the cloth and copper plates within under pressure. As the construction and mode of working an hydraulic press is well known, it is not thought necessary to describe it, except that it should be said that the several presses *b, b*, are all connected together by the water pipe *c, c*, and are consequently all acted upon simultaneously by one pump or lever.

Intead of the machinery and hydraulic presses above described, it is proposed under some circumstances, to employ a close vessel to be filled with water, in which the cloths are to be placed, with the plates of copper as above described, and the pressure effected by the hydraulic pump, applied thereto in the ordinary way. Under either of the plans, however, it is proposed to heat the water in which the cloths are immersed, by steam conducted into the vat by means of a pipe from a boiler, in any convenient situation nearly contiguous, and in this heated medium the cloths are to remain from twelve to twenty-four hours, or perhaps more, according to the quantity of the cloth, its colour, and the required lustre, or height of dress which may be desired.

The second plan proposed is by rolling up the cloth in contact with a thin sheet of smooth copper, or other smooth, fine, but flexible substance.

Fig. 3, shews the front view of a machine intended to be employed for the purpose of rolling the cloth and sheet of copper together ; fig. 4, is a transverse section of the same ; *a*, is the roller, upon which the piece of cloth is first rolled, before it is brought to the machine ; *b*, is a roll, round which the sheet of thin copper, or other smooth firm material is wound ; *c*, is the roll, upon which it is intended that the cloth and sheet of copper together should be rolled ; *d*, is a pressure roller, held down with considerable force against the roller *c*, by means of a weighted lever, for the purpose of causing the lengths of cloth and sheet copper to be very tightly rolled together. It is unnecessary to point out the particular arrangement of toothed wheels, by means of which, the several rollers are made to turn simultaneously, so as to preserve the tension of the cloth ; it is only to be observed, that the cloth must be delivered with considerable tension, in order

that it may be pressed firmly by the surface of the sheet copper by which it is to be enveloped.

Motion is given to the rollers by a winch, or by a band passed over the rigger *e*, which by the gear of pinions and wheels, causes the cloth and sheet copper to be drawn tightly as they are wound on, and when that is done, the roll is enclosed within a wrapper of canvass or any other material, and very tightly braced, and afterwards immersed in a boiler, and treated in the way usually practised when submitted to the ordinary operation called roll boiling.

Instead of the sheets of copper above mentioned, the Patentee proposes under some circumstances to employ slips of wood, closely fitted together, and held fast by rods passed through them, and screwed up at the ends, see fig. 5; these slips of wood are to be rendered perfectly smooth, and their lengths to correspond with the breadth of the cloth, and as many may be connected together as will form a flat smooth tablet, equal to the length of twenty-two yards, which tablets may then be employed as the smooth surface to press against the face of the cloth in the vat, in place of the sheets of copper, as above described

The other apparatus to be attached to a gig mill or brushing machine, for the purpose of distending the cloth in breadth, while it is under the operation of brushing or gigging, is a skeleton roller, formed by ribs of wood, which ribs are enabled to slide endwise.

Fig. 6, is a representation of this skeleton roller; *a, a*, is the axle that it turns upon; *b, b*, the ribs, of which there are two series mounted in the blocks *c, c*, each series reaching to about the middle of the roller. The one set of the ribs slide in one direction, and the other set in the

opposite direction, which movement is effected by the following contrivance: —

The ribs are attached to blocks, and enabled to slide therein by dovetails or by pieces on their under sides, let into sockets cut in the blocks in the form of the letter T, and they are slidden to and fro in those sockets by means of a stud on the under part of each rail, which acts in an oblique groove in one of the end pieces *d, d*.

These end pieces *d*, slide loosely round the axle of the skeleton roller, but are prevented from revolving with the roller when it is in operation, by a projecting pin *e*, extending outwards from each end piece, which pin is intended to stop against a fixed part of the frame of the gig mill or brushing machine, to which the apparatus may be attached.

It will now be perceived that as the skeleton roller goes round when mounted in a machine, the studs on the under part of each rib being inserted into the oblique groove in the stationary blocks *d, d*, that the ribs will be severally slidden outwards as their studs approach those parts of the oblique grooves which are farthest from the centre of the machine, and inward as they approach those parts of the oblique grooves which are nearest to the centre of the machine, the ribs continuing, as the roller goes round, to slide outwards at the front part of the roller, and inward at the back part of the roller.

It is only necessary further to say, that the ribs being slightly notched on their outer surface, take hold of the cloth as it passes over them, and by sliding outward, of course distends it breadthwise, and keeps the cloth tight and free from wrinkles, as it advances to the brushing or tease roller of the gig mill or brushing machine.

This last part of the invention, which is extremely ingenious and simple, appears to have been found very

effective in brushing and dressing machines, and is now in extensive operation in many of the clothing works in different parts of the kingdom; the pressing, or former part of the invention, has not however yet we believe been sufficiently matured to answer its purpose in a satisfactory manner.—[*Inrolled in the Rolls Chapel Office, February, 1830.*]

Specification drawn by Messrs. Newton and Berry.

To THOMAS GETHEN, late of Furnival's Inn, in the county of Middlesex, but now of Dursly, in the county of Gloucester, Gentleman, for his invention of certain improvements in dressing woollen cloths.—
[Sealed 21st November, 1829.]

THE nature and intention of this invention is to submit or place the cloths to be operated upon by the process of boiling, scalding, or steaming, in such form and manner as is hereinafter described, that it may receive during either of the above processes, a continued equal and undisturbed pressure. The machinery and apparatus necessary for the purpose, are made and used in the following manner:—first, provide a vat or cistern of such length and breadth, as the goods or cloth to be operated upon may require. Thus for instance, if it is wished to operate upon woollen cloths, of the customary trade lengths, of twenty-one yards long, and sixty-three inches wide, provide a vat or cistern about twenty-two yards long, and eight feet wide, upon which a lid made steam tight is to be fitted, which with the whole of the apparatus is represented in Plate X, and shown in several figures, of which fig. 1, is an end view of the vat shewn in section; fig. 2, a side view of the same and fig. 3, a top view, the similar letters referring to corresponding parts of the

apparatus in all the three figures. Provide long planks *a, a*, of about three inches thick and eleven inches deep, or several planks connected together at their ends, so as to constitute a sufficient length when placed edgewise along the bottom of the vat or cistern, to reach or extend the whole length of the vat or cistern. These planks are to stand in parallel rows, at the distance of from two to three feet apart, and have mortice holes cut through them in the manner described in the figures, in order to receive the bottom press bars, as hereinafter described.

The bars which communicate the pressure, are made and used in the following manner, and are distinguished by the following names, viz. the main bottom bars *b, b*, the main top screw bars *c, c*, the bottom cross bars *d, d*, the top cross bars *e, e*, the top saddle bars *f, f*, and the bottom saddle bars *k, k*, and the sister bars *g, g*; the main bottom bars *b, b*, are placed across the vat or cistern through the morticed holes *h, h*; in the planks *a, a*, the bottom cross bars *d, d*, are placed in like manner across the vat or cistern, and rest in the notches *i, i, i, i*; the bottom saddle bars *k, k*, are placed lengthways of the vat or cistern, each of them resting or laying upon one of the main bottom bars *b*, at about the middle or centre of each main bottom bar, and the ends of the bottom saddle bars *k*, press under the middle of the bottom cross bars. The sister bars *g, g*, are placed in notches made in each end of the main bottom bars *b*; a pin is then passed through holes made in the main bottom bars, and through the sister bars *g, g*, by which pin they are connected together.

I then provide boards, which I call press boards, for the purpose of pressing the cloth. In making these press boards, I take a supposed given length of twenty one yards long and sixty three inches wide, as enabling me to

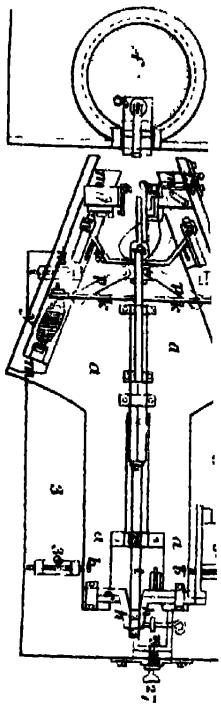

Fig. 6

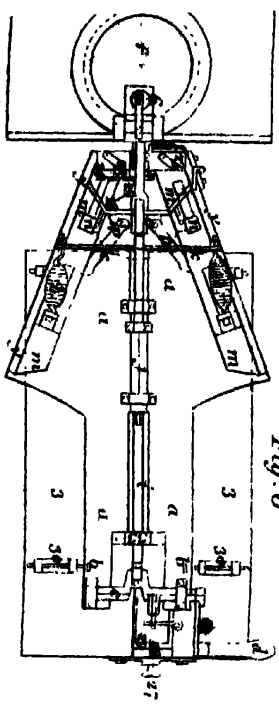
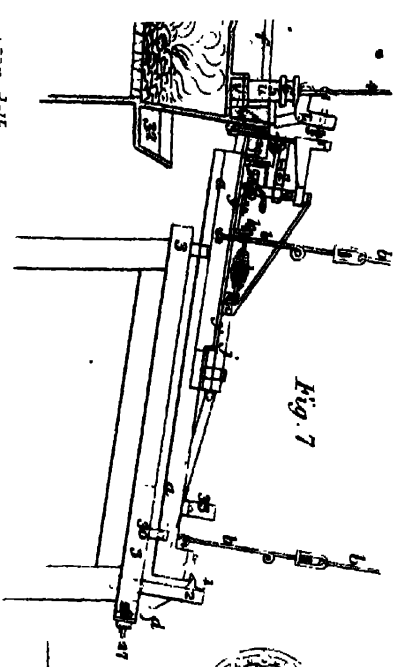

Fig. 7



1772

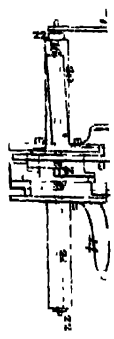

Fig. 9

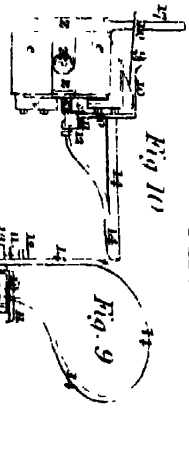
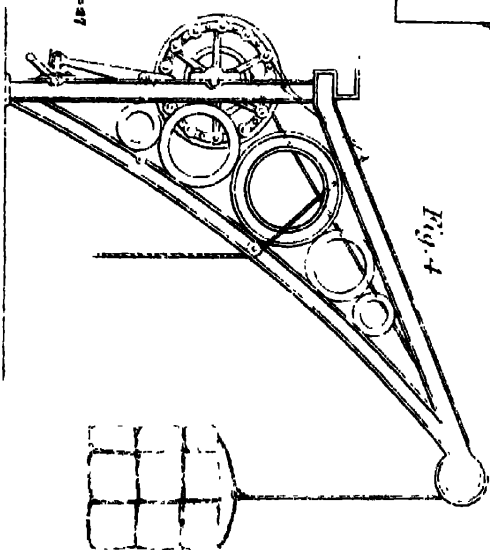

Fig. 10



1773

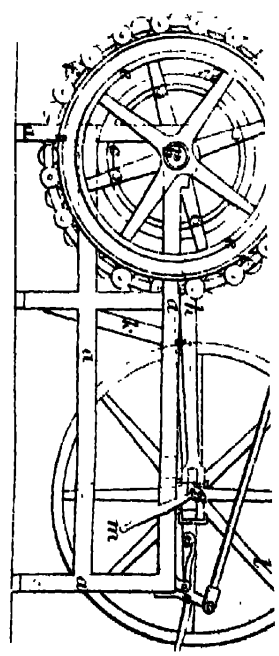

Fig. 1

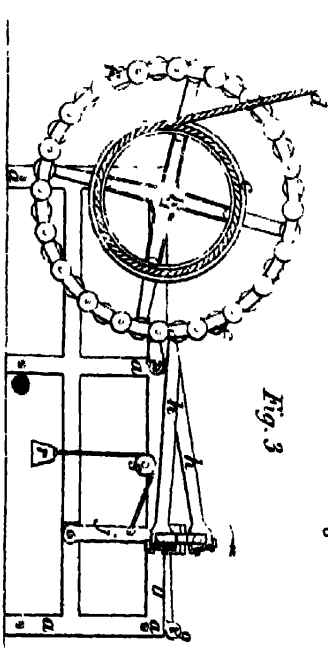
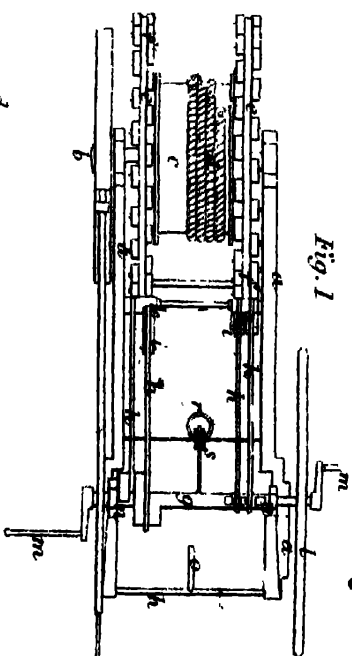

Fig. 3

1774

•

•

•

give a more clear and distinct description both of making the apparatus as well as of carrying on the process, but I claim the right of employing the same kind of apparatus to cloths of all lengths and breadths. For this purpose I saw out beech or other suitable boards of about three quarters of an inch thick and about nine feet long, and as wide as the timber will permit, which I recommend to be placed transversely or diagonally upon and across the edges of the planks *a, a*.

The beech or other suitable boards are carefully jointed to each other and dowelled together, and their ends are then sawed off to make the press boards of the required breadth. In order to keep the joints of the beech or other suitable boards firmly together, thin brass or other plates are screwed, or otherwise fastened across the joints upon the ends of the boards. The whole surface of the press board is then made smooth. In or upon these thin brass or other plates, small studs or hooks are fixed, to which the chains and the irons *l, l*, are to be attached, in order to move the press boards when required. At the height of about ten feet from the bottom of the vat, beams are placed across the building in which the vat is situated, for the purpose of supporting the machinery by which the press boards are to be drawn up and let down, and removed from or brought to the vat.

This machine for raising and carrying the press boards is intended to be moved on the beams by toothed pinions *p*, taking into racks *q*, fixed to the beams. The method of moving a press board to or from the vat or cistern, is by attaching the chains and irons to the hooks or studs, when by turning the wheels *m, m*, the shafts *n, n*, with the sheaves *o, o*, upon them, are put in motion, whereby the chains *l, l*, are wound round the sheaves *o, o*, and the press board is thereby raised up or let down.

In order to move the press board sideways after it is

wound up, the shafts with the sheaves *o, o*, are mounted in the carriages *r, r*; these carriages are moved along the beams by turning the handle of the pinion shaft *p*, which pinion taking into the rack *q*, causes the machinery to travel along the beam, observing that on the top of each of the beams grooves are made to guide anti-friction rollers placed under the carriages *r*. In order to place the cloth in the vat ready to be operated upon (it having been previously raised or rowed at the gig mill), it is laid flat upon a press board, care being taken not to disturb the face of the cloth; another press board is then placed upon the cloth, and then another cloth is laid upon the second press board, and again another press board is placed upon the cloth, and so on; a cloth and a press board may be placed alternately until so many cloths as may be convenient be laid or placed in the press.

When the required number of cloths are placed in the press (a press board being the last at top), the top cross bars *e*, are placed across the upper press board; the top saddle bars *f, f*, are then placed or laid lengthways of the vat or cistern, and made to lay or rest upon the top cross bars. The main top screw bar *c*, is then placed across the top saddle bars *f*, and the sister bars *g, g*, being attached to the top main screw bars *c*, in the same manner as they are described to have been attached to the main bottom bars. The screws *s, s*, as shewn in the main top screw bars *c*, are then turned so as to press the top saddle bars *f, f*, by which means the top cross bars *e*, are pressed down, and at the same time the sister bars *g, g*, by drawing up the main bottom bars *b*, force or raise up the bottom saddle bars *k, k*, and also the bottom cross bars whereby an equal degree of pressure is given and received at the top and bottom of the press boards. I wish it to be observed that though I have here described the pressure as being obtained by means of the screws *s*, yet I do not in-

tend to confine myself to the use of screws, under all circumstances, as an effective pressure might be obtained by the application of levers with weights, or by the immediate force of gravitation, or by some other contrivances.

The press being screwed tight and the lid of the vat or cistern placed thereon, steam from a boiler is conducted along the bottom of the vat or cistern, by a pipe, which pipe having small holes made in it at regular distances, will permit the steam to pass into the cistern, whereby a regular heat is produced therein, when it may be prepared to boil or scald the cloth in water, the vat or cistern is to be filled with water, sufficiently high to cover the press boards, and the cloth and the water to be made hot by any of the methods usually adopted for such purpose; the degrees of heat must be regulated according to the colour of the cloths under operation; cloths in a white state may receive as high as 212 degrees of heat, Fahrenheit, but above 160 degrees will endanger the colours of blue; black, and brown cloths, will bear one hundred and sixty degrees, or some of the best dyed black and brown colour, will not be injured at one hundred and eighty degrees, or even higher; the more delicate colours will not bear so high a heat, but they are to be regulated in regard to the degrees of heat, in the same manner and in the same proportions as the heat is increased or decreased upon coloured cloths, when they are submitted to the usual practice of boiling, scalding or steaming coloured cloths, when rolled upon rollers. The time allowed for the process should be about six hours, after the heat is up to the degrees stated above that is to say for black cloth, when the steam or water has acquired about one hundred and sixty degrees of heat, that heat should be continued about six hours, and the same rule should be observed in regard to the heat re-

quired for other colours, that is reckoning six hours from the time at which the heat necessary for each colour, is up to the degrees stated above.

The operation may be repeated one, two, or more times, or even oftener, when it be wished to obtain a higher lustre, or when the cloth has been submitted to the operation one or more times, it may with advantage be rolled and boiled, or scalded in the usual manner. The cloth should be taken out of press between each time of performing the operation, allowing it first to have become perfectly cold, and after being taken out it is to be run up at the gig mill with plenty of water.

The above described methods of placing a board between each cloth will give a particular style of face to the cloth, which may also be done in a manner nearly as advantageous, by placing two cloths between each press board in the following manner—that is, by laying or placing a cloth with its face side downwards upon the press board, and a second cloth being laid or placed with its back upon the back of the former, both of these cloths will, upon a press board being laid or placed upon them, receive the pressure of a press board upon their face sides. Two cloths and one press board may thus be continued alternately in the same manner as with cloths laid or placed singly between the press boards as described above. Instead of laying or placing the cloths in press in either of the above described modes or methods, a cloth may be laid upon the lower press board, a second cloth may then be laid or placed upon the first, and then a third upon the second, and so on cloths may be laid or placed in succession upon each other till the required number be in press, when a press board being laid or placed upon them, and the press being set and screwed, they may receive the process of boiling, scalding, or steaming.

And, lastly, I consider that inasmuch as this my improved machinery or apparatus, when employed as above described, affords the means of effecting an improvement in the dressing woollen cloths, and avoids the creases or fold marks, produced by the short presses hitherto in use; and that as this my invention is an improvement upon the process of dressing of woollen cloths (as hitherto carried on or effected by the said short presses), I am entitled to all the privileges and advantages which may occur or rise from the exclusive use of this my apparatus or machinery, which I claim as new in its constructions and application to the purpose of pressing cloth, while under the operation of boiling, scalding, or steaming.—
[*Inrolled in the Rolls, Chapel Office, May, 1830.*]

Specification drawn by Messrs Newton and Berry.

To SAMUEL MORAND, of Manchester, in the county palatine of Lancaster, merchant, for his invention of an improved stretching machine.—[Sealed 14th April, 1831.]

THIS improved stretching machine is for the purpose of extending the width of calico pieces, or of other cloths or fabrics which are woven of cotton, silk, wool, flax, or other like material, in cases when such woven fabrics have become shrunk or contracted in width in consequence of dying, bleaching, or other process to which the said woven fabrics may have been subjected. The manner in which this invention is to be applied is shewn by several figures in plate X. Fig. 4, represents a lateral elevation of the machine in its complete state. Fig. 5, is a horizontal view or plan representing the chains, chain races and pins,

cross rails and card roller, hereinafter described, placed on the frame in order for working. Figs. 6 and 7, represent two elevations of the opposite ends of the machine, the chains and chain races being omitted. In the several figures the same letters of reference are used to denote the same parts of the machine.

Figure 4. *a, a, a*, represent side frames of iron, connected by the cross rails 1, 2, and 3, (best seen in fig. 5,) and by the cross bars *a, a*, as seen in figures 6 and 7. These frames support the axis *w*, of two chain wheels *g, g*, the side of which is shewn in figure 4, and the edges and axis of both are shewn in fig. 7. The wheels *g, g*, are moveable along their axis *w*, and can be fastened on any part of the length thereof, by binding screws *w, w*, (as seen in fig. 7,) or otherwise. The two wheels *g, g*, may be fitted on their axis *w*, with squares or with fillets, which will allow the wheels to move freely along the axis, but not to turn round thereon, and instead of binding screws to fasten the wheels on the axis, projecting brackets similar to those hereinafter referred to by the letter *m*, may be fixed on the ends *d*, of the chain races, to reach down to the central crosses of the wheels *g, g*, and to enter into circular grooves formed around those central crosses, in order to retain those wheels from sliding along their axis, except when the chain races are being adjusted on the cross rails, and then the said brackets will adjust the wheels *g, g*, correspondent to the adjustment of the chain races.

The axis *w*, of the wheels *g, g*, gives motion to the machine and may be turned by hand, by means of the winch or handle *z*, or by any other adequate power. At the other end of the frame, but not fixed to it, are two other similar chain wheels *h, h*, to which are attached spur wheels *i, i*, of rather larger diameter, which

work against the spur pinions k, k , to the inner sides of which are attached rollers or pulleys k, k , which are called the pricking pulleys, and which are situated over the chain wheels h, h , as shewn in figs. 6 and 8. The wheels h, h , are not both fixed on one axis, but each wheel with its spur wheel i , turns on a centre pin mounted on a bracket as hereinafter mentioned, as is also each of the pinions k, k , with its pricking pulley k . The centre pins for the wheels h, i, h, i , and k, k, k, k , are all supported by brackets m, m , with three arms, one of which is fastened to the outside of each of the chain races b, c , best seen in fig. 5, at the foremost end b , thereof; another of the arms reaches downwards to support the centre pins of the wheels h , and i , and the third arm extends upwards to bear the centre pin for the pinion k , and its pricking pulley k , seen in fig. 6. Two similar brackets r , fig. 6, are fixed to the inside of each of the chain races b, c , at the said end b , to bear the other end of the centre pin of the wheels h , and i , but these brackets r , are without the third arm extending upwards l, l ; fig. 10, is a roller covered with a card of the sort commonly used in carding cotton, and its situation is indicated in fig. 6, by dotted lines.

An endless chain o, o , (which is made of brass) is applied on each pair of wheels g , and h , in grooves made in the face of each wheel, as shewn in figs. 6 and 7. This chain in its passage between the points b , and d , fig. 4, is carried through a chain race b, c, d , supported by bearers sliding in slots in the cross rails.

The outer surface of the chains is studded with pins, fig. 13, fixed at equal distances of about three quarters of an inch asunder, as shewn in fig. 11, which during the passage of the chains over the wheels when in work, enter into suitable holes in the face of the pricking pulleys

k, k, represented in fig. 8. At *c, c*, are joints or hinges in the chain races, in order that the ends *b, b*, of the chain races may be made to converge and diverge, and the wheels *h, h, i, i*, and *k, k*, and the pricking pulleys *k, k*, being attached by the brackets *m, m, r, r*, to the ends of the chain races converge and diverge together, with them. *e*, is a small handle wheel with spokes, the axis of which *f*, gives motion to the mitre wheels *f, f*, best seen in fig. 5, and thereby to the right and left hand screw *g*, shown in fig. 9, which represents an upright view of the cross rail 1, seen in fig. 5. The bearers slide in slots in the cross rails, by means of the nuts which are fixed to the bearers, and pass through the slots, as seen in fig. 9, and which nuts are perforated by the right and left hand screw *g*, which in its revolutions work in its nuts and thereby increases or diminishes the distance, between the bearers and the foremost ends *b, b*, of the chain races, which are attached to them.

A similar apparatus may, if thought fit, be attached to the other cross rails, for the purpose of increasing or diminishing the distance between the bearers and chain races on them. Fig. 8, represents a lateral view of one of the chain wheels *h*, and the pricking pulley *k*, with a portion of the chain *o, o*, and its pins passing between them; the spur wheel *i*, and pinion *k*, are supposed to be removed in this representation. Fig. 11, represents the upper surface of three links of the chains; the black spots represent the holes in which the sharp pointed pins (see fig. 13) are to be screwed; the links are of two sorts, broad and narrow, placed alternately and connected by joints formed like those of hinges, and which project beyond the surfaces of the links, as is seen in figs. 4 and 8; the joints must be fitted rather loosely, so as to admit of sufficient lateral play in the chains for converging and diverging. The

grooves cut in the faces of the chain wheels leave of course raised edges on each side ; notches are cut in these edges, as shewn in the figs. 6, 7, and 8, each notch being of a sufficient size to admit a broad link of the chain, and the two connecting hinges, and the distance between every two notches being equal to the length of one of the narrow links without the hinges. When therefore the chains are placed on the wheels, the broad links lie in the notches, whilst the narrow links lie between the raised edges, as shewn in fig. 8, and on the wheels *g, g*, being put in motion, the chains are propelled by the pressure of the raised edges of the wheels against the projecting joints of the broad links of the chains, whilst the wheels *h, h*, are carried round by a corresponding action of the chains against the raised edges of those wheels, and they, by the cog wheels *i, i*, best seen in fig. 6, turn the pinions *k*.

Figure 12, represents a cross section of the chain races *b, c, d*, and a cross section of a broad link of the chain is represented by dotted lines in its place within the chain race, with one of the pins ; fig. 12, represents one of the pins, with its nut and screw complete ; fig. 10, represents the card roller *l, l*, with pulleys *l, l*, fixed on at each end of its axis ; over each of these pulleys a friction cord is placed, one of which is fastened to the frame of the machine, and from the other end I suspend weights in order to retard the motion of the roller as much as may be necessary, so as to bring the fabric to the pricking pulleys as tight and straight as possible.

To perform the operation of stretching by means of this machine, first adjust the chain races by sliding their bearers along the cross rails 2 and 3, and fastening them in their slots by suitable binding screws at such parts of the said cross rails as will place the parts *c, c*, and *d, d*, so far apart that the distance between the pins of the

respective chains may be equal to the breadth to which the selvages of the fabric are required to be finally stretched; then adjust and fasten the wheels g, g , at a corresponding distance on their axis w , so that the chains may pass from them to the chain races in a direct line; next adjust the ends b, b , of the chain races in like manner to the present or contracted breadth of the fabric.

The distance of the chain races at the ends b, b , are adjusted by means of the wheel e , and its connected apparatus before described, and the distance at the points c, c , and d, d , are generally adjusted by hand, but it may be done by the application of apparatus similar to that used to adjust the ends b, b . The chain races, when thus set, diverge from the points b, b , to the points c, c , and are parallel from c, c , to d, d , as seen in fig. 5.

When the fabric is to be stretched, it must be in a damp state. If it has been recently stiffened, or has undergone any similar operation, by which it has been thoroughly moistened, it may have retained sufficient moisture from such operation, but otherwise water is to be used for damping the fabric.

The fabric being thus wetted and being gathered upon a roller or otherwise, pass it over the card roller l, l , so as to bring the edges of the piece straight and evenly over the endless chain o, o , and beneath the pricking pulleys k, k , best seen in fig. 6, where I stick the end of each of the selvages on the pins of the chains at b, b . The chain wheels g, g , being then turned steadily round by the moving power applied in the direction indicated by the bent arrow in fig. 4, both the chains revolve, carrying forward with them the fabric, the selvages or edges of which are progressively fastened on the pins by the pricking pulleys k, k , forcing the selvages down on the pins as the chains move forward. The chains in their progress

with the fabric from b, b , to c, c , continue to diverge until at c, c , they attain their utmost intended separation equal to the required breadth of the piece, the fabric stretching as the chains to which its edges are fastened gradually diverge.

The chains with the fabric having passed the points of extreme divergence c, c , continue their progress at the same distance apart to the ends of the chain races d, d , thus retaining the fabric a sufficient time in its stretched state, to give permanence to the increased tension of the fabric, which is then taken off by hand or otherwise.

Note.—The overhanging borders at the upper sides of the chain races (best seen in fig. 12), along which the edges of the piece slide, and which are made very smooth to facilitate such sliding, should rise up, with inclined planes at the ends d, d , so as to raise up the edges of the piece above the level of the tops of the pins, in order to detach the said edges from their points.

In order that the fabric may retain more exactly the width obtained at the points c, c , heat may be applied to the surface or surfaces of the fabric, to dry it during its passage from c, c , to d, d , but the application of heat forms no part of my invention, and is therefore not claimed by me.

In order, if necessary to tighten the chains and make them work more truly, a tightening pulley pressed down by a weight, may be applied to bear upon the lower returning of each chain. The size and proportions of the different parts of this improved stretching machine, as well as the materials of which the parts of the machine are to be composed, may be varied at the discretion of the constructor, according to the description of the cloth or fabric to be stretched by it.

Having now described the improved stretching machine, and explained the mode in which it is to be used, for extending pieces of calico or other fabrics of cloth in width, the Patentee says that he claims as his invention, the combined application of all the several parts in the way he has described, to form an improved stretching machine, for the purpose of stretching calico or other fabric of cloth in width, in the manner hereinbefore set forth, but I make no claim to any of the several parts in their individual characters, except as to the construction of the endless chains fig. 11, with their pins fig. 13; and the adjustable chain races, fig. 12, for receiving and guiding those chains, and also the construction, as hereinbefore described, of the pricking pulleys *k, k*, seen in figs. 6 and 8. which stick the selvages of the pieces upon the pins of the chain.—[*Inrolled in the Rolls, Chapel Office, October, 1831.*]

Specification drawn by the Patentee

To CHARLES CUMMEROW, of Lawrence Poultney Lane, Cannon Street, in the city of London, merchant, in consequence of a communication made to him by a certain foreigner residing abroad, for certain improvements in propelling vessels.—[Sealed 10th Dec. 1828.]

THE invention described in the Specification of the above Patent, is the application of a revolving horizontal propeller or paddle, formed by a sheet of thin metal, coiled once round a shaft in a helical or spiral curve, as the thread of a screw. This paddle or propeller is to be immersed underneath the water at the stern of a boat, in a horizontal position near the keel of the vessel; on

rotatory motion being given to the axle of the propeller, it is supposed that the coiled shape of the paddle will screw itself through the water, and cause the vessel to move forward.

There is an elaborate description given in the Specification of this invention, but its want of novelty is so obvious, that it is not necessary for us to say more upon the subject.—[*Inrolled in the Inrolment Office, June, 1829.*]

To WILLIAM FURNIVAL, of Wharton, in the county of Chester, Esq. for his invention of certain improvements in evaporating brine.—Sealed 21st February, 1831.]

THE invention specified under this Patent relates in the first place, to an improvement or an invention patented by Joseph Tilt, 4th April, 1827, for “certain improvements in the boilers used for making salt, commonly called salt pans, and in the mode of applying heat to brine;” a report of the specification of his patent will be found in Vol. II, Page 283, Second Series of this Journal; and which Letters Patent, and all liberties, rights, and privileges thereby granted, have been assigned by Mr. Tilt to the present Patentee, as it is stated in his Specification.

The improvement on the invention of Mr. Tilt consists in placing angular pipes or tubes within salt pans in such manner, that there is a space left beneath them for the deposit of the crystals of salt as they are formed, and which are allowed to descend on to the bottom of such salt pans. The upper surfaces of the angular pipes or tubes, permit the crystals of salt to roll off them in

the same manner as the angular roofs, described by Mr. Tilt in his Specification. The second part of this invention, consists in forming the cover of a salt pan double, to contain brine in it, which brine will receive the heat from the steam, which is evaporated from the brine contained in the salt pan; but the brine contained in the double cover is not permitted to evaporate until it is drawn off into the salt pan, whereby crystallization is prevented within the double cover.

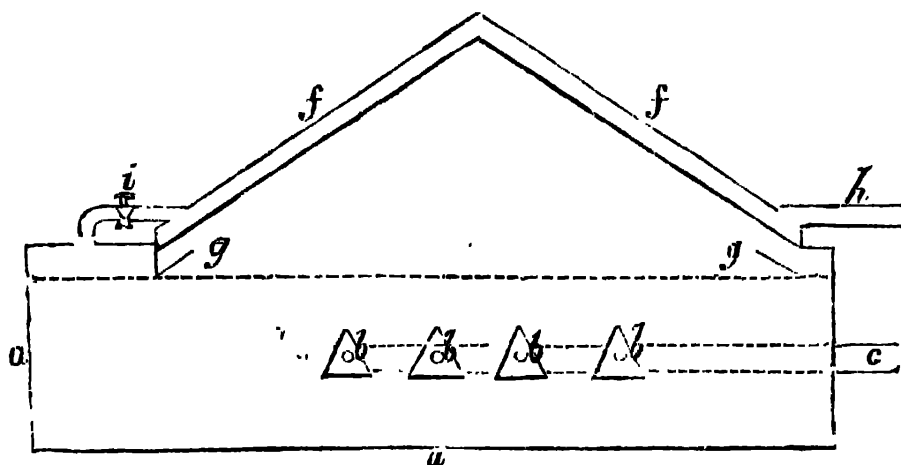

The above figure is a transverse section of a salt-pan with these improvements adapted to it; *a, a, a*, is the salt-pan, having four angular tubes or pipes *b, b, b, b*, extending from end to end; these tubes or pipes are connected together at one end by short pipes to a main steam pipe *c, c*, on the outside of the pan; this pipe conducts steam from a boiler to the angular tubes *b, b, b, b*, for the purpose of heating and evaporating the brine contained in the salt-pan *a, a*. To the ends of these angular tubes there are also affixed cocks or valves to permit the escape of the air, or the entering of the steam from the main-pipe *c*, and the condensed steam may be drawn off from the angular tubes by small pipes.

In working the pan with this improvement the crystals of salt are to be removed from time to time from off the bottom of the salt-pan, by scraping underneath the angular pipes, and drawing the crystals of salt to the sides of the pan, and removing them by skimmers or perforated shovels in the usual way.

The second improvement is also shewn in the figure, and consists of the double cover *f, f*, which from its peculiar construction has a larger surface for condensation, and conveys the condensed steam away, without permitting it to fall back again into the brine in the pan, thus possessing advantages over other angular or curved covers.

The double cover is placed over and extends from end to end of the salt pan, by which means the steam as it rises from the brine, condenses on its under surface, and gives out its heat to the brine contained within it, until it becomes condensed, when it runs down the under surface, and is collected in the troughs *g, g*, formed on each side to receive and convey it away, without permitting it to fall into the brine; *h*, is a pipe for supplying brine to the double cover *f*, from a reservoir, which will cause it to be kept continually full of brine, and at the same time will not allow it to evaporate, until it is drawn off into the salt pipes by the press and cock *i*, whereby the brine does not crystallize within the cover; the brine heated in the cover is to be drawn off into the salt pan, from time to time in the same rate as is found to take place in the evaporation.

The Patentee states in conclusion, that having described the nature of his improvements, and the manner of carrying the same into effect, he wishes to observe that although he has shewn and described only four angular pipes or tubes *b*, yet he does not confine himself to that number

nor to the angle shewn in his drawings, as the same may be varied, care being observed that they are constructed so that the crystals will not lodge as they are formed on their upper surfaces, but descend into the brine to the bottom of the pan.

The angular pipes or tubes the Patentee prefers to be made of copper, sufficiently strong to bear the pressure of the steam used for heating, yet he does not confine himself to the use of that metal, and that the angular pipes or tubes may have furnaces or fire places formed in them, as described in specification of Joseph Tilt. In constructing the double cover, he usually forms the same of iron or copper, in one continuous chamber, but it may be constructed in separate compartments, either running longitudinally or the reverse.

And he claims as his invention:—" first, the placing of angular pipes or tubes in salt pans, in the manner above described, for evaporating the brine, such angular pipes or tubes being above the bottom of the salt pans, and consequently having brine beneath them. Secondly, he claims the placing of a double cover over the surface of the brine undergoing evaporation, such double cover being filled with brine, to be heated by the steam arising from the salt pan, but the brine contained in the double cover, not being permitted to evaporate till it is drawn off into the salt pan, whereby the brine is prevented forming into crystals within the cover as above described. —[*Inrolled in the Petty Bag Office, August, 1831.*]

To WILLIAM SUMNER, of Hose, in the county of Leicester, lace-maker, for his having invented or found out certain improvements in machinery for making lace, commonly called bobbin-net.—[Sealed Feb. 6, 1831.]

THESE improvements consist in the construction of certain novel pieces of mechanism, and their adaptation to that particular kind of machinery for making lace, known by the name of the Lever's machine. The object of these improvements is to enable the Lever's machine to make that peculiar sort of lace which is denominated in the trade fancy net, or bullet rolling, arranged in various patterns.

These improvements may be described under three general heads—first, a mode of shogging or shifting laterally at intervals certain portions of the combs, by means of an indented wheel, acting against a sliding bar, on which these shifting portions of the combs are mounted. Secondly, a mode of shifting or shogging laterally certain of the pushers at intervals, corresponding with the movements of the combs above mentioned, in order to bring the said pushers into or out of action at those times ; and, thirdly, the adaptation of a tappet or cam wheel, to shog or shift the point bar, in accordance with the other movements.

The operation of some of these parts very closely resembles the ordinary mode of forming selvages between the narrow stripes of lace called breadths when made in a Lever's machine, except that, instead of the long spaces between the selvages, which are connected together by a zigzag thread, the movements of the machinery, about to be described, cause the thread to traverse and occasionally to close the spaces forming the open parts of the net into circular holes.

The movements of the bobbins to produce the breadth, or series of narrow stripes, in one sheet, with distinct selvage on each strip are called turnagains (a term and operation well understood by lace-makers in general).

In plate IX, fig. 7, is an elevation of a machine for making lace, constructed on the Lever's principle; the general appearance of the front of the machine is here shewn, though some of its minor parts are omitted, and they are exhibited in the situations in which they are to be placed in the machine; *a, a*, is the warp roller; *b, b*, the work roller; *c, c*, the front point bar; *d, d*, the front pusher bar, on the top of which lies an auxiliary pusher bar *e, e*; on this bar *e, e*, are mounted a series of extra pushers to be occasionally brought into operation, as will be explained hereafter; *f, f, f*, is the bar carrying the extra combs to effect the turnagains; *g, g*, is a rod affixed to the turnagain comb bar, the extremity of which is acted upon by a horizontal wheel *h*, having indentations in its periphery. This wheel *h*, is mounted upon a perpendicular shaft, carrying a cog-wheel *i*; this cog-wheel, and consequently the shaft and the wheel *h*, is driven by a pinion upon the shaft *j*, which shaft is the axle of the Dawson's wheel; this shaft *j*, is to be actuated by a click as usual. The extra comb bar *f*, is kept stationary as long as the outer extremity of the rod *g*, works against the circular part of the periphery of the wheel *h*; but as that wheel revolves whenever one of the recesses or indulations in its periphery comes opposite to the outer extremity of the rod *g*, the rod is allowed to slide to the right, and will then be drawn outwards a short distance by the force of a vertical spring, by which movement of the bar *f*, the extra combs are shogged or shifted one gate to the right hand, and on the circular part of the wheel *h*, coming round and acting again upon the end of the rod *g*, the bar is then

shogged or shifted to the left back into its former situation.

The auxiliary pusher bar *e*, is kept stationary by means of a projecting arm *k*, fixed to that bar, carrying a tooth at its upper end, and the point of which tooth acts against the periphery of a small wheel *l*, and is drawn up to its bearing by a helical spring attached at the bar *e*, and at the other end to the stationary frame. This wheel *l*, is mounted on a carriage fixed to the front pusher bar, and has certain indulations or recesses cut in its periphery, and as the wheel being made to revolve whenever one of these recesses comes opposite to the tooth *k*, the bar *e*, is allowed to slide to the left, and being drawn by the helical spring shoggs or shifts the extra pusher at that time, so as to bring them to act upon those bobbin carriages which have, by the shifting of the bar *f*, been brought into the previously vacant spaces at the turnagains.

The small wheel *l*, is made to turn upon its axis by the following means:—

Upon an axle mounted in a carriage fixed upon the front piston bar alongside of the wheel *l*, is a small ratchet wheel *m*, in the underside of which ratchet two pins are fixed; these pins, when the ratchet goes round, successively take into the teeth of another small ratchet wheel *n*, upon the axle of *l*, and consequently every rotation of the wheel *m*, drives the ratchet *n*, two teeth, and also the wheel *l*, part of a rotation. A catch *o*, fixed to the front comb bar stands up sufficiently high to meet the teeth of the ratchet wheel *m*, every time that the pusher bar *d*, which carries these wheels is raised, consequently by the opening and closing of the machine in the ordinary course of working, at every stroke of the handles the ratchet wheel *m*, is made to strike against the catch *o*, which drives it one tooth, and thus after a certain number

of successive beats of the machine, the wheel *l*, being driven round one of its recesses, comes opposite to the tooth *k*, and allows the extra pusher bar *e*, to shog or shift in the manner already described. As it is necessary to keep back the front pusher bar *d*, and prevent the pusher going in among the carriages, where the carriages in the fancy bar *f*, have to shog at the turnagains, I have introduced a small wheel *p*, with two notches in its edge, against the circular part of the periphery of which wheel, a tooth *q*, is intended to act; this tooth *q*, extends inwards from an arm affixed to the front pusher bar, and consequently the pusher bar is, while the tooth bears against the circular part of this wheel *p*, kept back until one of its notches comes opposite the tooth. The wheel *p*, is driven round by a stationary click *r*, taking into the teeth of a small wheel *s*, fixed on the same axle as *p*. The stationary click *r*, is fixed by an arm to the standard of the machine, and the ratchet *s*, and wheel *p*, are mounted upon the front landing bar, hence every time that the machine opens, that is, the front bars raise the click *r*, drives the ratchet *s*, one tooth, and one of the notches of the wheel *p*, is thereby brought at the proper times opposite the tooth *q*, and the pushers then go in and act upon the carriages as usual.

Fig. 8 is a section perpendicularly through the machine in a transverse direction, in which the situation of the extra pusher bars *e*, *e*, are shewn with the wheels *l*, and *n*, and tooth *k*, which are the same in construction and situation at the back of the machine, as I have described in reference to the front.

In order to shog one of the point bars, and bring it into corresponding action with the movements of the combs and pushers already described for the purpose of forming the bullet-holes, a small cam or tappet wheel *v*,

is mounted in a carriage attached to the back point bar shaft, towards the left end of the machine, which cam or tappet as it revolves acts against a tooth *u*, at the end of the sliding joint of the back point bar and shogs it to the right once in every rotation, the bar being brought back again by a helical spring. This cam or tappet wheel *v*, is driven round by a ratchet-wheel upon its axle, striking against a stationary click *w*, attached to the frame, which ratchet is driven one tooth every time that the back point bar descends for to take up the half mesh.

When I wish to produce an arrangement of the bullet-holes in the net in zig-zag directions, or in any other form across the net, deviating from straight perpendicular ranges, I attach a horizontal wheel *x*, to the upper part of the perpendicular shape which carries the wheels *h* and *i*; the periphery of this wheel *x*, I cut into indutations for the purpose of working the bolt *y*, which is connected to and drives the comb bar as in ordinary machines; but by means of the indutations on the periphery of this wheel *x*, the comb bar is occasionally traversed to arrange the pattern or direction of the bullet-holes.

The Patentee observes that as it is impracticable in this specification to contemplate every variety of pattern of bullet holing, which might be made in lace upon this improved machine, so it is unnecessary to point out all the variations in the indentations which the shogging wheels would require to produce such different patterns, as any competent lace maker will perceive in what manner and order to make the indentations and elevations on the peripheries of the several wheels *h*, *l*, *p*, *v*, and *x*, and what number of teeth to give to the several driving toothed or ratchet wheels, which will depend upon the size of the pattern.

The specification concludes by saying—Having described the construction of my improvement and the manner of their adaptation to a Lever's Machine, I lastly desire it to be observed, that I do not intend to confine myself to the precise situations, dimensions, or forms of the new parts as exhibited in the drawings, knowing that they may be slightly varied and still retain the same operative effects, but I rest my claim of invention to the employment of auxiliary pusher bars, and to the shogging of the said bars, and also the shogging of the extra comb bar and point bar, by means of cams or wheels, with indentations for the purpose of shifting the situations at the turn-agains, and causing them to change their traverse occasionally and not continually as in making breadths, and thereby with the assistance of shogging, the print bar to form that description of fancy or ornamental net having circular interstices called bullet holing.—[*Inrolled in the Rolls Chapel Office, August, 1831.*]

Specification drawn by Messrs. Newton and Berry.

On the Friction and Resistance of Fluids. By GEORGE RENNIE,
Esq. V. P. R. S.

Read before the Royal Society, June, 1831.

WHEN on a former occasion I communicated the results of a series of experiments on the Friction and Resistance of the Surfaces of Solids (*Philosophical Transactions for 1828*), I stated that they formed part only of a series of experiments on the nature of friction generally. My object at first was to trace the relation subsisting between the retardation produced by the surfaces of solids in motion when in contact with each other and with fluids; but finding that the subject connected with either of these branches was sufficiently extensive, I deemed it necessary to postpone the second part of the inquiry to a future occasion. Those experiments, however, established some important facts. They showed that (within the limits of abrasion) friction was the same for all solids, and that it was neither affected by surface nor

velocity, Subsequent experiments upon rolling bodies of great weight and magnitude, when the resistance was reduced one thousandth part of the mass, and the surfaces in the ratio of thirteen to one, have corroborated the affinity of resistance between rolling and sliding bodies. Thus in connecting and continuing the isolated experiments of Coulomb and Vincc, and assigning values to the abrasive resistances of most of the most useful solids, a considerable advance has been made in the science.

The subject of the present paper, however, involves difficulties of a more complicated kind. The theory of solids as deduced from the laws of mechanics, and independent of experiment, may be applied to any system of bodies; but the theory of fluids, in which the form and the disposition of the particles, or the laws of their action, are unknown, must necessarily be founded on experiment; and even with this aid, which can only be obtained through the intervention of a solid, our knowledge of the true properties of fluids must be vague and uncertain. Accordingly we find that the subject of fluids attracted the attention of some of the most distinguished mathematicians and philosophers of Europe for the last two centuries; that is, from the year 1628, when Castelli first published his *Treatise on the Measure of running Water*, down to the hydraulic investigations of Eytelwein and Young. Between these periods, Italy, France, Germany and England, added their contributions to the science. But it is to the Italians principally that we owe the foundation of it, in their numerous investigations and controversies on the rivers of Italy; hence the writings of Castelli, Viviani, Zandrini, Manfredi, Polini, Frisi, Gulielmini, Lechi, Michellotti, and of many others.

Each of them has endeavoured to establish a theory applicable to rivers and torrents, but in general with indifferent success. The science again received fresh accessions from the more valuable investigations of Bossut, Dubuat, Venturi, Funck, Brunning, Bidone, Coulomb, Prony, Eytelwein and Girard; and among our own countrymen, of M'Claurin, Vince, Matthew Young, Dr. Jurin, Professor Robinson, and the late Dr. Thomas Young. Sir Isaac Newton had already demonstrated, in his celebrated propositions 51, 52, and 53 of the *Principia*, (in the case of a cylinder in motion immersed in a fluid,) that the resistance arising from the want of a perfect lubricity in fluids is (*cæteris paribus*) proportional to the velocity with which the parts of a fluid separated from each other; and that, if a solid cylinder of infinite length revolves with a uniform motion round a fixed axis, in a uniform and infinite fluid, the periodical times of the parts of the fluid thus put in motion will be proportional to their distances from the axis. This theory (although conformable to experiment) was objected to by Bernoulli and D'Alembert, on the

ground that Sir Isaac Newton had not taken into consideration the centrifugal force or friction arising from the pressure of the concentric rings or filaments round the cylinder, the fluid being supposed in a state of permanence, and the friction of the rings equal throughout.

Pitot (1728), in his experiments on the water-works at Marly and Versailles, was the first to demonstrate with equal velocities, and in the ratio of the volume of water, the friction of water in pipes was in the inverse ratio of their diameters; and Couplet (1733), Marriotte, and Deparcieux, estimated the difference between the real and calculated expenditures of glass tubes and pipes.

Chezy (in 1771 and 1786) was the first engineer who endeavoured to establish the relation subsisting between the inclination of an aqueduct and the transverse section of the volume of water it ought to carry,—on the supposition that the accelerating force, due to the inclination of the bed of the conduit, is counterbalanced by the resistances of the channel in the ratio of the surface, and increasing in proportion to the square of the velocity. What Chezy had remarked was concluded by Bossut, who cleared the investigation of most of its difficulties, and demonstrated it to be in accordance with theory. He found that small orifices discharged less water in proportion than great ones on account of friction; that the vena contracta, and consequent expenditure, diminished with the height of the reservoir; he pointed out the law by which the discharge diminishes according to the inclination and number of bends in a pipe, and the influence of friction in retarding the velocity of waters moving in canals and pipes, in which he made the square of the velocity to be in the inverse ratio of the length of the pipe; he determined the co-efficients by experiment, and thus obtained a formula expressive of the conditions of the uniform motion of water in open canals. The greater part of these hypotheses may be said to have been removed by the more extensive researches of Dubuat. His great hydraulic work, published in 1779 and 1786, contains a series of the most valuable observations, whose results accord very nearly with the new formula of the motion of water in pipes and open conduits; and his experiments, with pipes inclined in various angles from the 40,000th part of a right angle to 90 degrees, and in channels which varied from a line and a half in diameter to areas of seven or eight square toises, seem to comprehend every case of inclination; so that by collecting a prodigious number of facts, both with compressible and incompressible fluids, he obtained a general expression for all cases relative to the friction and cohesion of fluids: but a logarithmic function which he introduces in it, by a sort of approximation, gives it a character of uncer-

tainty, which restrains its use, and shows the necessity of fresh researches. Venturi, in 1798, " *Sur la Communication latérale du Mouvements dans les Fluides,*" repeated and added many new facts to the experiments of Bossut, on the expenditure of differently shaped orifices and tubes, but particularly on the lateral communication of motion by the cohesion of fluids. Coulomb first approximated to the solution of the question, by a very ingenious apparatus, consisting of discs of different sizes, fixed by their centres to the lower extremity of a brass wire, and made to oscillate in fluids by the force of torsion only; he concluded that the resistance was a function, composed of two terms, one proportional to the first, the other to the second powers of the resistance: again, that it was not sensibly increased by increasing the height of the fluid, but simply by the cohesion of the particles of the fluid which presented greater or less resistance, in proportion to the viscosity of the fluid, oil being to water in the ratio of 17.5 to 1. But whatever might be the conclusions of Coulomb, it is obvious that both the size and construction of his apparatus were ill calculated to produce results whereon to found a satisfactory theory; and accordingly both Messrs. Prony and Girard, in expressing their formulæ of resistance, have not admitted that of Coulomb, but have adopted the mean of the best of experiments made by other authors: but as these formulæ give only the mean velocity, which is much greater than the velocity (of the fluid contiguous to the pipe) which ought alone to enter into the expression of the retarding force, it follows that the co-efficients deduced from the mean of all the experiments adopted by these gentlemen, have a value greatly inferior to the motion of the fluid contiguous to the side of the pipe or conduit. To ascertain correctly the value of this kind of resistance, M. Girard (*vide les Mémoires des Scavans étrangers* for 1815), undertook a prodigious number of experiments on tubes of different diameters and length, from which he deduced that the retardation is as the velocity simple. The effects of temperature are very remarkable: if the velocity be expressed by 10, when the temperature is 0° centigrade thermometer, the velocity will be 42°, or increased four times when the temperature is 85°: these values must be deemed approximations only.

The contributions of British philosophers towards the improvement of this science have been, unfortunately, scanty; for, with the exception of Sir Isaac Newton (who led the way), Dr. Jurin, Dr. Matthew Young, Dr. Desaguliers, Dr. Vince, Mr. Smeaton, Mr. Banks, and the late Dr. Thomas Young, (see the paper of the latter gentleman in the *Philosophical Transactions*, and his commentaries on Eytelwein's experiments), we can scarcely find any experiments on the subject; whatever has been effected by our

engineers or scientific men, has either been withheld from the public, or consigned to obscurity; and though we have tracts of marshes and fen land, consisting of many thousand acres, the dissertations on the mode of draining and carrying off their superfluous waters are confined to local pamphlets and reports, of comparatively minor interest to the science of hydraulics.

From the foregoing short but imperfect history, it is obvious that much has been done towards perfecting this science. It is however certain, that much yet remains to be accomplished; and although we are deeply indebted to both the French and English philosophers for their extensive investigations on the laws of capillary attraction, the descents of globes in fluids, and the adhesion of fluids to metal discs, the phenomena of fluidity, and the laws which govern the motion and equilibrium of their particles, must yet remain a problem purely geometrical; and as we possess no tangible means of approximating to the solution of the problem, but through the intervention of a solid, we must content ourselves, in like manner, with the imperfect formulæ deduced from experiments made on a small scale on the friction and adhesion of water in pipes and conduits, until we can ascertain more correctly the causes of the retardations of rivers as they occur in nature.



LITERARY AND SCIENTIFIC MISCELLANY.

Druidical Remains. A few days ago Mr. Cole of Scarborough discovered in the vicinity of the village of Cloughton, a druidical circle, near to the one pointed out by John Wharton, Esq., a few weeks since. It is about twelve yards in diameter, having the altar stone remaining, and is in a direction bearing N.N.E. from the Wharton circle. Its site is in a vale, called Hulley's Hack, and near it flows a clear spring of water. It is bounded by the plantation nominated Lind Ridge or Rigs, on the opposite elevation.

Highland Scenery. An extensive pictorial and trigonometrical survey of the Highlands and islands of Scotland has been commenced this year by Lieutenant Colonel Murray, who has already traversed a large portion of the West Highlands.

A P P E N D I X

To the Report of the Select Committee of the House of Commons, on Patents.

Papers delivered in by John Farey, Esq.

[*British Law of Patents for Inventions.*]

(Continued from page 108.)

THE specification, after describing the stove, thus claimed as the invention, “ that the fuel necessary for supplying the fire, shall be introduced at the lower part of the grate, in a perpendicular or oblique direction ; as to the manner of performing it, that is set forth in the description and drawings.

It was proved that grates for cooking had been made before, with moveable bottoms, to be raised up by racks and pinions, and with doors to shut against the front bars, so as to conceal the fire ; but those were schemes to contract or enlarge the depth of the fire-grate, according to the size of the meat to be roasted ; and the doors were to shut in the heat for cooking, when the fire was not required for roasting ; it was never thought, or intended, to use the doors to form chambers, which would contain a supply of fuel, that could be introduced into the fire places from below upwards.

Lord Ellenborough was of opinion, that the principle on which those grates were constructed, was identical with the concluding terms of the specification ; that the patentee, by thus summing up the extent of his invention, had confined himself to that principle, which was not new ; and therefore the patent could not be supported, although the application of the principle, as described in the specification, might be new. The patent was ordered to be cancelled, and repealed

Bovill against Moore and others. An action brought by direction of the Lord Chancellor, for Infringement of Brown’s Patent of 1811 (assigned to Bovill), for “ a machine for the manufacture of Bobbin Lace or Twist Net, resembling Buckinghamshire Lace, as made by hand, with Bobbin on Pillows.” Tried in the Common Pleas, 1st March 1816, before Lord Chief Justice Gibbs. Verdict against the Patentee.

The machine was for making several narrow breadths of Lace, side by side. The fabric of real Buckinghamshire lace requires two systems of threads, like the warp and weft in cloth ; the longitudinal threads extend lengthways of the piece, and intertwist

with diagonal threads, which latter traverse the breadth obliquely, from edge to edge, and then return with an opposite obliquity, whereby the different diagonal threads, which are so traversing in opposite directions, cross each other, and their intersections form the tops and bottoms of the hexagonal meshes of the lace; the sides of those meshes being formed by the inter-twisting of the diagonal threads, with the longitudinal threads.

All the varieties of lace that could be made by machines founded upon Morris's patent of 1764, were only imitations, by knitting-work, without any diagonal threads or twisting, which are essential conditions to make lace, which will retain the figure of its meshes after washing.

The first successful machine for making the real twist lace, was Heathcoat's patent of 1809; he warped the longitudinal threads on a roller, and wound up the lace on another roller, as fast as it was made, as the warp is wound in a loom for weaving cloth, only the warp stood in a vertical plane; the weft was supplied by a very different principle from common weaving; for in lieu of a shuttle, each of the diagonal threads was wound upon a separate thin flat bobbin, shaped like the sheave of a pulley, and about the size of a shilling; they were all placed in a row, side by side, in proper carriages, without touching each other, thus forming as many distinct shuttles as there were threads in the warp. In the operation, the row of bobbins was put through the spaces between the upright warp threads, penetrating through the plane of the warp from front to back, and after making a small lateral movement, the bobbins were returned again through that plane, or between the vertical warp threads, from back to front; each bobbin, in so doing, passed and returned at the opposite sides of its corresponding warp thread; and by repeating that manipulation, each bobbin thread became twisted around each warp thread, so as to make the sides of a row of hexagonal meshes. The twisting being done, the bobbins were arranged in a new order in their row, by passing each one round to the other side of its neighbour, by moving sufficiently sideways. This evolution effected the mutual crossings of the diagonal threads, each one crossing over the adjoining one, so as to make the tops and bottoms of the row of hexagonal meshes. A correct shape was then given to that row of meshes, by inserting a row of pins into them, to keep them open to the proper size, whilst a succeeding row of meshes was formed, as before; by first twisting the longitudinal threads with the adjacent diagonal threads, then crossing the adjacent diagonal threads over each other, and then inserting another row of pins, to give shape to the meshes so formed.

Heathcoat's machine was applied to make wide pieces of lace net, but it was also capable of making a row of distinct breadths,

by some modifications in that evolution, whereby the bobbins were new arranged in their row, in order to effect the crossing of the diagonal threads. That was a subsequent improvement.

Brown's machine, which was begun after Heathcoat's was in use, was expressly intended to make breadths of lacc; it reversed and inverted Heathcoat's system of working; thus the threads wound on the distinct bobbins, formed the longitudinal threads in the lace, and the threads warped on the roller, were the diagonal threads. This variation occasioned such changes in all the mechanical movements of the machine, as rendered it very different from Heathcoat's, and its position was also inverted; but Brown adopted Heathcoat's principle of having one-half of the threads on distinct bobbins, arranged in a row, so as to pass and repass between the warp threads, in order to effect the twisting of those two sorts of threads together. The crossing of the upright warp threads, each one over its neighbour, was effected in Brown's, by a piece of machinery which had been invented by Morris in 1781, in an attempted machine, which failed for want of introducing diagonal threads; but Brown, in adopting Morris's abortive contrivance, added a new one of his own, which caused the warp threads, after being so crossed, to continue to traverse obliquely all across the breadth in opposite directions, and to return, on arriving at the edges; that was effected by giving the horizontal roller on which the threads were warped, an additional rotatory motion, about an imaginary centre, at the middle of its length, so that the two ends of the roller went round in a horizontal circle.

Brown's specification had many drawings, which described all the separate parts of which the machine was composed, and also represented the whole machine put together, but it was difficult to understand how some parts were to be put together in the machine, which was exceedingly complex. There was also an omission of the means which the patentee used, to cause the diagonal threads to return, when they arrived at the edges of each breadth; for, by following the specification literally, the diagonal threads of each breadth would have been carried obliquely onwards into the adjoining breadths, so as to entangle therewith. The specification did not point out any distinctive character of the invention, but said, "my invention consists as represented in the drawings," and then described all the parts of the machine.

The infringement of Brown's patent was proved by two engineers, who had been sent, by order of the Lord Chancellor, to examine defendant's machinery.

It was contended, that the circumstance of the warp threads from the roller, becoming diagonal, constituted a new invention; for in twisting the two sorts of threads together, the warp thread was enabled to be the actor, and the bobbin thread was acted upon;

and that thereby the lace was made with better selvages than Heathcoat's; that although Heathcoat had commenced law proceedings against Brown, for infringement of his patent of 1809, he had never ventured to come to a trial. On the other hand, it was contended, that the specification claimed the whole machine: when, in fact, the bobbins and their movements, by which the twisting was effected, were Heathcoat's, and also part of the machinery, by which the crossing was effected, was Morris's; also, that the specification was defective in instructions how to make the proper selvages, to the distinct breadths which was the great object of the patentee, and his only claim to superiority over Heathcoat's machine.

Lord Chief Justice Gibbs: The patentee must show that he has performed all the conditions upon which the privilege was granted to him, and particularly, that he has described the mode of manufacture, so as to enable any competent person to make it, after his term is expired. In his specification he is bound to confine himself to that which is his invention; and if he has exceeded the limit of what he has invented, and for which he is entitled to the sole privilege, though there may be no other objection to his patent, that will overturn it. According to this specification, whatever is contained in the drawings annexed to it, is claimed as new invention, and if it is all new, he is entitled to maintain an action against any one who shall practise any part of what is represented.

It is not disputed that the machine is new, as far as respects a certain part of the manufacture, nor that the machine is useful. The evidence is uniform, that with the exception of some slight difficulties, a workman of common skill would be able to make the machine, by applying a great deal of attention to it (which so complicated a machine, however described, must necessarily require), and bringing a competent degree of skill. The specification ought also to enable a workman to use the machine to the extent most beneficial, within the knowledge of the patentee at the time; without reserving to himself any more beneficial way of working. This specification does not point out certain precautions which are actually used, in all these machines, and without which there would be danger of the diagonal threads of each breadth, entangling with those of the adjoining breadth; but it appears that that entanglement might be corrected as it occurred, if the workmen exercised a competent degree of attention. If Mr. Brown has since discovered and applied an improvement for that purpose, his patent will not be affected by his using his own machine in that improved state, for he will have added to the original merit of his invention, the further merit of using it more beneficially. But if at the time when he obtained his patent he was apprised

of such more beneficial mode, and did not communicate it to the public, that would be a fraudulent concealment, which will render his patent void: it appears that no machines have been used by him, without such improvement.

The evidence has shown, that the originality of the machine, is in the mode of obtaining the longitudinal threads from the distinct bobbins, and the diagonal threads from a warp roller, which roller, besides turning round on its own axis to allow the thread to unroll from off it, has another revolving motion, around the middle of its length; so that the two ends of the roller describe a horizontal circle, in order to disperse its threads diagonally over the breadth of the lace, in two sets, which traverse that breadth with opposite obliquities. But although the invention may be beneficial, and in that respect new, the specification will be bad, if it states him to have invented that which was known before, because that affects to give him a larger privilege, than could legally be granted to him. The novelty of the contrivance by which the warped threads are made diagonal, is admitted, excepting the machinery for crossing those threads, which was borrowed from Morris; but the evidence states, that all which precedes the operation of crossing the threads, had been previously practised, by substantially the same means, in Heathcoat's machine, the principle being the same in effect.

In the case of *Boulton and Watt v. Bull*, the infringement by Bull was an engine, which, on the first view, had not the least resemblance to Watt's, for the head was placed where the feet were looked for; but he had taken the principle, which acted as well one way upwards as the other; and when Bull's engine was set upright, it was exactly like Watt's. So Brown's machine makes lace at the bottom of the machine, by a downward operation, and Heathcoat's made lace at the top of the machine, by an upward operation, which must be considered as the same in point of invention. I think I may state, that all that precedes the crossing of the diagonal threads is old, whereas he has stated it as part of his invention; and also that some of the parts by which those threads are crossed are old. Brown's patent ought to have been only for an improvement; and certainly his specification should have pointed out those parts which were of his invention, and to which alone his privilege applied. If a combination of parts, forming a certain portion of Brown's machine, existed before, and he took up his combinations at that point, and went on combining beyond that, he has no right to the former combinations, and his specification, claiming the whole machine as his invention, is bad. But if he had the merit of inventing the combination of all the parts from the beginning, his specification is good.

The jury thought the defect in the specification "might be in-

advertent, and not fraudulent;" the Judge observed, " if he knew it, and did not state it in his specification, he must answer for his inadvertence." They then found, that " the combination of the parts up to the crossing of the threads, is not new ; that the threads then taking a new direction, which is the most valuable part to the plaintiff, is a new invention ; but it is nothing more than an improvement."

On the 3d May 1816, a motion was made for a new trial, but it was refused.

Lord Chief Justice Gibbs : Some confusion has been made between a new machine for making lace, and making lace on a new method, by a machine partly old and partly new. The present patent grants the sole use of the machine, and whoever imitates it, either in part, or in the whole, is subject to an action from the patentee. If it had been a new invention from beginning to end, and Heathcoat had afterwards made the machine described in his specification of 1809, is there any doubt, but that such machine would have been an imitation of part of Brown's invention? The evidence proved that up to a certain point, Brown's was an imitation of Heathcoat's. The drawings to Brown's specification are divided into different sections, each containing a portion of the machine, in a different stage of the progress of making it ; one of those sections contain the principle of distinct bobbins, to pass and re-pass between the perpendicular threads of the warp, in order to effect the twisting ; it was proved that the whole of that section existed in Heathcoat's machine ; and that a combination carried no farther than that, was a useful step of invention towards a complete machine.

Mr. Justice Dallas : The law is quite clear, that if an invention be only an addition to an old invention, the patent must be for that addition only ; as in Jessop's case of a particular movement in a watch. The question is, whether Brown's machine be a new invention *in toto*, or from a certain point only. The witnesses said, that if Heathcoat's machine had been made after Brown's, it would have been an infringement on Brown's patent ; such patent therefore, to the extent contended for, must be void.

Mr. Justice Park : The law was most correctly stated by his lordship to the jury ; it is not new law ; for in the *King v. Else*, Mr. Justice Buller held, that where the invention consisted of an addition, or improvement only, a patent for the whole machine was void. In the present case, the jury have found, that up to a certain point, the machine acts like the former one, and that the invention is only an improvement. The verdict was confirmed against the patentee.

Newbery against James and others in Chancery. An application to dissolve an Injunction previously issued, to restrain De-

defendants from making or selling, and from disclosing the composition of Fever Powders, for which Dr. James (grandfather of one of the defendants) had a Patent in 1747; also of the Analeptic Pills, for which no Patent had been obtained. Heard 27th March 1816, before Lord Eldon. Injunction dissolved.

Dr. James, the grandfather of defendant, made agreements with Mr. Newbery, the father of plaintiff, in 1747 and 1755, that Dr. James, his executors, &c. should exclusively prepare those medicines for Mr. Newbery, his executors, &c. who should have the exclusive sale. Those agreements were to continue for an indefinite time, and been acted upon till lately; when, in consequence of an alleged violation, an injunction was granted as to the sale only of the medicines; and this was an application to remove the injunction.

Lord Chancellor Eldon: "How can the specific performance of the agreements be decreed? If the composition of the medicines is a secret, how can this court enforce any order that it might make? If it is not a secret, what is the ground for interfering? The patent for the fever powder is long expired, and it is required to enforce an agreement, by which the parties (independently of that patent) covenanted not to sell the patent article, except through each others hands. The specification ought to enable all the world now to use the invention; and if the preparation of the analeptic pills were a secret, what signified an injunction? For unless a disclosure were made, the court possesses no means of determining, on any occasion, whether it had been violated or not. The party who comes to complain of a breach of injunction, must first show that it has been violated. The injunction must be dissolved; the defendants to keep an account of what they sell, whilst the right is tried at law."

Note.—It was a mis-statement to the court, that there had been no patent obtained for the Analeptic Pills; Dr. James had a patent for them in 1774; but the specification is not intelligibly worded.

Heathcoat *ex parte* in Chancery. An opposition to sealing a Patent to Lacy, for a machine for making Twist Lace or Bobbin Net, to be worked by Steam power; on the ground, that the proposed Patent did not require the Specification to be enrolled, until fifteen months after the date. Heard 25th July 1816, before Lord Eldon. Seal refused.

It was stated that the patentee intended to apply to parliament, as in *Lec's case* (53 Geo. III. c. 179) to withhold the specification from public inspection, in order that the invention might not be sent abroad, and that fifteen months was necessary to make that application to parliament.

The Lord Chancellor Eldon said he could not put the seal to a patent which allowed fifteen months for enrolling the specification; that indulgence had been rarely granted. Mr. Lee's was a very peculiar case, being thought a most important discovery, and in time of war. If the patent could be made out to be as beneficial, it would be doubtful whether a secret specification would be allowed; for his lordship was of opinion, that the legislature would pause a long time before they passed such an act in future; and he would venture to say, Mr. Lacy would not procure one. He could not establish a new principle, merely to prevent the French from smuggling; nor put the great seal to such a patent, without seeing the specification, for it might turn out good for nothing. The patent could not pass without the responsibility of the great seal, and if he sealed it, he might be called upon to give an account in parliament, why he had extended to this individual a particular privilege, which is contrary to the general policy of the law. He could not, in justice to the King's subjects, seal this patent, merely because it was a manufacture which other countries might wish to get.

Note.—On this refusal, a new patent was made out, with six months for enrolling; it was sealed 30th September 1816. The invention was afterwards practised to a considerable extent, but did not succeed, and has been abandoned in favour of other machines having the same object.

Walker against Congreve in Chancery. An application for enforcing an Injunction previously issued against violating Walker's Patent of 1810, for Barrels for preserving and conveying Gunpowder. Heard 27th July 1816.

The Lord Chancellor Eldon said, "An injunction may be issued against violation of a patent which has been obtained with all the necessary forms, although on examination the patent may be found improper." Defendant might show reasons for dissolving the injunction, but was bound by it, whilst it was in force, and would commit a contempt in disobeying it. So an injunction might be issued against a public servant, who, as such, was not liable to the consequences of a private suit, and therefore an injunction ought not to have been issued; still the authority of the court must be respected, and the injunction dissolved by the court, not broken by the party against whom it issued. In cases of penalties for contempt, all alleviating circumstances were matters for consideration, and he would hear the case before deciding on the question of contempt.

From that hearing, it appeared very doubtful to his lordship whether the patent had really been infringed, or could be maintained; the powder-barrels made by defendant, which formed the

subject of complaint, being as much like some old ones, made years before, as they were like those described in the specification. His lordship said, that the injunction must be dissolved, and an account kept of the articles made by defendant, until the validity of the right could be tried at law. "The injunction had been granted upon the statement, that it was a new invention, and that the defendant, in addition to making barrels for the public service, had also supplied East India ships. After the injunction was made, it should have been observed, till dissolved by the court. I will treat government here as I would any other suitor of the court; and as there are grounds for believing the injunction violated, the defendant must pay the costs of this application."

List of Patents

*Granted by the French Government, from the 1st of April to
the 30th June 1831.*

(Continued from Vol. VII. page 356).

-
- To Mr. Auguste Noverre, of Paris, additions to his 10 years patent for a kneading machine.
- Nicolas HouzEAU Muiron, of Rheims, additions to his 10 years patent for a new method of transporting gas.
 - Claude Compagnot, of Paris, for a method of rendering soles of shoes waterproof. 5 years.
 - Archbald, of London, for a new process of working cane juice to extract at once the crystallized particles. 15 years.
 - Olivier Benoist, of Plailly, for an improved harrow with three wheels. 5 years.
 - Robert Hicks, surgeon of London, for improvements and additions to his patent for baking bread.
 - Thomas Ingram, of Leicester (represented in Paris by A. Perpigna, French and foreign patent agent, 28, Rue Neuve St. Augustin,) for improvements in the generation of coal-gas. 15 years.
 - Henri Pape, piano-maker, of Paris, additions to his patent for improvements in the sounding-board of piano's.
 - Jacques Wall, tinman, and Charles De Larcleye, engineer, of Paris, second improvement on the 10 years patent for a new lamp.

- To Antoine Dominique Sisco, locksmith of Paris, fourth improvement on the five years patent taken out by him for an instrument called "monte ressort boite."
- Jean Tulien Josselin, laceman, of Paris, fourth improvement on his five years patent for a new kind of stays.
 - Martial Betoulle, of Limoges, for a new instrument for measuring distances. 5 years.
 - Charles Beaumont, of Paris, for an apparatus called hydrostatic moderator. 5 years.
 - Joseph Alexander Robert, of Paris, for improvements in fire-arms. 15 years.
 - Pierre Louis Bcauduceau Père, engineer, of Paris, for a new hydraulic wheel. 15 years.
 - Jean Felix Renaud, dyer, of Lyons, for additions to his five years patent for an improved process of dying.
 - Theophile David Frankfort, of Paris, for additions to his 15 years patent for a new method of laminating bronze.
 - Louis Brunier, architect, of Paris, for additions to his 15 years patent for a *perpetual hydromotor*.
 - Pierre François Delacroix, chemist, of Rouen, for a new kind of stove called by him "multiplier." 10 years.
 - André Etienne Trompette, of Paris, for a new method of hanging cabriolets. 10 years.
 - Adrien Gustave Demilly, of Paris, for cast iron fire logs. 5 years.
 - Bryan, Donkin, and Co. engineers, London, for improvements in making paper. 5 years.
 - Charles Pierre Reusse Dolmenasse, of Paris, second improvement on the 10 years patent for a new kind of carriage called *impulsive*.
 - Adrien Jean Pierre Thilouer, of Paris, for an improved machine for compressing coal-gas, 10 years.
 - Christophe Matthieu de Dombarle, of Roville, for an apparatus for extracting the sugar from beet root. 15 years.
 - Jean Claude Clare, engineer, of Sedan, for a new machine called *hydro-atmosphérique*, applicable to various purposes. 10 years.
 - Gilles Cyveyre, of Nimes, for a machine for spinning silk. 5 years.
 - Constant Gouche, of Paris, for an economical blue. 5 years.
 - Jean Claude Chabert, of Paris, for a new kind of stove. 5 years.
 - Richefeu and Fleschelle, of Paris, for additions to their 15 years patent for a kneading machine.
 - Couleaux, Ainé and Co. of Molsheim, for additions to their 10 years patent for improved coffee mills.
 - Gilbert M. Aubergies, druggist, of Clermond Ferrand, for a machine for making grooved bricks. 5 years.

- To Jean Louis Cabias, curate of Pontigny, for a new system of playing on the organ. 5 years.
- Louis Auguste Gautier, druggist, of Havre, for a new method of making beer. 5 years.
- Antoine Joseph Gros, of Paris, for improvements on his 10 years patent for paintings on horse-hair cloth.
- Gerard Frédéric Courboulis, of Vouziers, for a new method of teaching to read and spell correctly. 5 years.
- ——— Teandau, of Chalons, for additions to his 10 years patent for a machine applicable to all purposes of raising water and draining.
- Antoine Perpigna, of Paris, French and foreign patent agent, for an improved machinery applicable to looms. 5 years.
- George Harris, of London, for a new method of making ropes, sail cloth, &c. 15 years.
- James Milligan, of London, for a new method of purifying sugar. 15 years.
- Picrre Remi Duchesne, umbrella maker, for a new kind of umbrella. 5 years.
- Felix Joseph Klein, of Strarburg, for a new life preserving system. 15 years.
- Pierre Jean Guerin, of Paris, for a new kind of vehicle called *coupee cabriolet*. 5 years.
- Rabaud, Freres and Co. of Marseille, for an apparatus calculated to raise ships above water. 15 years.
- Verebint Freres, of Toulouse, for a new system of making bricks by machinery. 10 years.
- Joseph Saluon, engineer, of Paris, for a new system of navigation. 15 years.
- Marler François Gullaume, of Paris, for a new kind of flour mill. 10 years.
- André Lioret Fils, of Paris, for a cart for carrying fire wood and delivering it in the measure. 5 years.
- Charles Auguste Drousart, of Neuilly, for a new fabric called *philippoine*. 5 years.
- Isaac Adolphe Læborde, of Bourdeaux, for a new kind of transparent paper. 5 years.
- Ennemond Felissent, of Lyons, for additions to his 15 years patent for an apparatus for drying through the medium of hot air.
- Jean Baptiste Rochelines, of Montpellier, for a safety coach. 5 years.
- Jean Marie Vouret, of Louviers, for a rotary fulling machine. 10 years.

List of Patents

*Granted by the French Government, from the 1st of July to
the 30th of September.*

- To Mr. Claude Jaillet, Jun. of Lyons, for a third addition to his 15 years patent for making ornamented stuffs.
- Amedée Joseph Rindenhagen, for a new sort of military trunk. 10 years.
- Vincent Pluriose Triquet, of Paris, for improvements in the construction of pianos. 10 years.
- Durand and Co. dyers of Saint Tiert, for improvements on their 10 years patent for ornamenting all kind of silk or cotton stuffs.
- Ennemoud Felissent, of Lyons, second addition to his patent for a system of dessication through the medium of heated air.
- James Milligan, of London, for an apparatus for regulating the temperature in generating steam. 15 years.
- Frederic Kalkbremer, of Paris, for a *hand-guide* to facilitate the study of the piano. 5 years.
- Touron and Co. for addition to their five years patent for painting on horse hair cloth.
- Jean Claude Chabert, and Louis Legus, of Paris, for a portable windmill. 10 years.
- Mr. Louis Honoré Boquet, of Series, for a mechanical ink-stand of all shapes. 10 years.
- Charles Auguste Drousart, of Neuilly, for additions to his five years patent, for a fabrick of his invention called *philippine*.
- Pierre Bollen, of Maisons, for additions to his five years patent, for a machine calculated to extract the fecula from potatoes.
- Christophe Joseph Mathieu de Dombasle, of Roville, for additions to his fifteen years patent, for extracting sugar from beet-root.
- Pierre Théodore Peqin, of Paris, for a machine for shelling corn and dry seeds, and making pearl barley.
- John Everth, of London, for a method of dividing the constituent parts of palm oil, and applying separately, 15 years.
- Thomas Lord Cochrane, of London, for an improved rotary steam engine. 15 years.
- Basile Duicl, of Lyons, for a new kind of stove for drying dyed silks, worsteds, &c. 10 years.

- To William Newton, of London, civil engineer, (represented in Paris by A. Perpigna, French and foreign patent agent, Rue Neuve, St. Augustin, 28), for improvements in touch holes and primers, suitable to percussion guns, pistols, &c. 10 years.
- Auguste Courtel, engineer of Lyons, for a machine for craping silk, cotton, or worsted stuffs. 10 years.
- Francois Barnabé Vouillemont, of Joiurille, for a cast iron plough. 10 years.
- André Jeaffram, of Tours, for a new hydraulic press. 5 years.
- Jean Boirin, of St. Etinne, for a new method of making gun barrels. 5 years.
- Adolphe Lamborton, of Marseille, for an improved pump. 5 years.
- Miles Berry, engineer, of London (represented in Paris by A. Perpigna), for an improved pedometer. 5 years.
- Louis Brumer, of Paris, for second improvement on his patent of fifteen years, for an hydraulic machine called *perpetual hydromotor*.
- Antoine Dominique Sirco, engineer, of Paris, fifth improvement on his five years patent, for an instrument called *monte-ressort-boite*.
- Charles Henri Storey, of Paris, for a sash window, proof against wind and rain. 10 years.
- Jean Téréme Pouillot, of Paris, for a method of combining combustible matters and making a fuel composite. 15 years.
- Pierre Isidore Rouen, of Paris, for an hydraulic lever to regulate the course and action of fluids. 10 years.
- George Choiry, of Paris, for a pedometer in the shape of a footstep, applicable to different kinds of carriages. 5 years.
- Abraham Emmanuel Jaccond, of Vienne, third improvement on his patent of 10 years for a new method of disposing wheels, pivots, &c. so as to retain the oil with which they are greased.
- Phillippe Aubin, of Paris, for a new process of making mosaic tiles. 5 years.
- Berard and Wilkinson, of Paris, for improvement on their 15 years patent for a new bobbin for spinning, drawing, and throwing silk.
- Philippe Taylor, of Paris, for improvement on the patent of 10 years, transferred to him by Macintosh for accelerating combustion.
- Antoine Moffateur, wheelwright, of Lyons, for a new system of raising water to the greatest heights. 5 years.
- Philibert Mousset, engineer, of Lyons, for an improved silk winder, 5 years.
- Louis Victor Antoine Sire, and Claude Antoine Joseph Girardot, of Vesoul, for an economical stove. 5 years.

- To Freres Fertugiere, of Ans, for a new method of making iron, or leaden balls, by means of a cylindrical roller. 10 years.
- Louis Sebastien Lenormand, of Paris, for a new system of lamp. 10 years.
- ——— Ramgo, brothers, watchmakers, for improvements on the patent of Mr. Sorel, legally transferred to them, for a new kind of steam engine.
- Pierre Licutard and Jean Joseph Ricard, of Var, for a new flour mill with conical grinding stones. 15 years.
- Nicolas Clément Desormes, engineer, of Paris, for substituting wood to charcoal in high temperature furnaces. 15 years.
- Henry Holdsworth, Jun. of Manchester, represented in Paris by M. Perpigna, French and foreign patent agent, for improvements in the means of working cotton, flax, silk, and other fibrous substances. 15 years.
- Philippe Taylor, of Paris, for a new system for measuring gas. 10 years.
- Joseph Gibson, of Lille, for a new system of making bobbinet. 10 years.
- Jean Baptiste Marie Joseph de Lancey and Nicolas Charoy, of Paris, for a new musket, firing two shots with only one barrel. 5 years.
- Taillepered de la Garenne, of Paris, for a new engine called by him *vicissim aqua terre*. 5 years.
- Onesiphore Pecqueur, engineer, of Paris, second improvement on his patent for a kind of boiler for refining sugar.
- Pierre Louis Etienne Guilling, for improvement on his patent for an apparatus which regulates the length of silk skeins.
- Zuber and Co. paper manufacturers, of Rixheim, for improvement on their 15 years patent for making continual paper.
- Charles Auguste Lupé and Louis Joseph Salmon, of Paris, improvement on their 20 years patent for reviving animal charcoal.
- Pierre Marie Bernard Rolein, of Rochfort, for improvement on his 15 years patent for an improved lock.
- Urbani Sartoris, of Paris, for a new kind of boat, called by him *cateau vanne*. 15 years.
- Nicolas Houzeau Miuron, of Reims, for a new process of making metallic tubes. 5 years.
- Jean François Corna, of Havre, for a new marine clock, opening as a turn spit. 5 years.
- Andrew Marouy, for a new harrow with three wheels. 5 years.
- André Etienne Trompette, of Paris, for improvement on his ten years patent, for a new method of hanging the body of a cabriolet.
- Ferdinand Leopold John, of Paris, for steel mechanical legs. 5 years.

- To Jean Forgues, engineer, of Bordeaux, for preserving houses from fire. 5 years.
- Hcuri Sanford, engineer, of Paris, for a machine for straining and cleansing the pulp from which paper is made. 5 years.
- Hippolyte Raimond Deschamps, for a new oven for drying plumbs. 5 years.
- St. Hainslas Benard, of Vendome, for an improved stove, 5 yrs.
- Francois Antoine Kenck, of Paris, for a machine for making pin nails. 5 years.
- Joseh Marie Giodiulli, and Charles Louis Harel, of Paris, for a machanical apparatus, called by them Volant a Percussion. 5 years.
- Purre Antoine Burat, of Paris, for improvement on their ten years patent, for new trusses for ruptures
- Francois Armand Caron, of Paris, for improvement on his five vears patent, for an improved lamp.
- George Choing, of Paris, for improvement on his five years patent, for his distance measuring foot step.
- Charles Auguste Drousart, for second improvement on his five years patent, for a new fabrick called *philippine*.
- Joseph Alexander Robert, of Paris, for improvement on his 11 years patent, for a new kind of fire arms.
- Antoine Reini Polonieau, of Paris, for a new kind of bridge. 15 years.
- Jean Boivin, of St. Etienne, for improvement on his five years patent, for making gun barrels.
- Nicolas Clement Désormes, engineer, for improvement on his fiftcen years patent, for using wood instead of charcoal, in high temperature furnaces.
- Ardaillon Bessy, and Co. for a process of making gun barrels by means of cylindrical rollers. 10 years.
- Antoine George, engineer, of Lyons, for improvement on his patent, for a thrashing and winnowing machine.
- Jacques Dominique Charles Garard, for secondimprovement on his ten years patent, for an apparatus for drawing and engraving, without any previous knowledge of drawing.
- Claude Marie Arestide Francois, for a paper or silk globe. 5 years.
- Thomas Hall, of Havre. for a machine to make tree nails. 5 years.
-

New Patents Sealed, 1831.

To Joshua Bates, of Bishopsgate Street, in the city of London, gentleman, in consequence of a communication made to him by a certain foreigner residing abroad, for an invention of certain improvements in machinery or apparatus for roving, twisting, or spinning cotton, silk, wool, hemp, flax, or other fibrous substances.—Sealed 27th October, for Inrolment.—6 months.

To Sarah Guppy, of Tarway House, Clifton, near Bristol, widow, for her having found out and invented a method of applying and arranging certain articles, parts or pieces of cabinet work, upholstery, and other articles commonly, or frequently applied to bedsteads and hangings, and also others not hitherto so applied.—27th October.—2 months.

James Macdonald, of the University Club House, Pall Mall East, in the county of Middlesex, gentleman, in consequence of a communication made to him by a foreigner residing abroad, for a certain improvement or improvements in the construction of bridges made of iron, or other materials, which improvement or improvements are also applicable to the construction of piers, rail roads, roofs, and other useful purposes.—31st October.—6th months.

To George Minter, of Princes Street, Soho, in the county of Middlesex, cabinet maker and upholsterer, for his having invented a fastening for dining tables, and other purposes.—9th November.—2 months.

To Thomas Brunton, of Park Square, Regent's Park, in the county of Middlesex, Esq. for his having found out or discovered a new application or adaptation of certain

apparatus for heating fluids or liquids, and generating steam for various useful purposes.—15th November.—6 months.

To Thomas Brunton, of Park Square, Regent's Park, in the county of Middlesex, Esq. and Thomas John Fuller, of the Commercial Road, Limehouse, in the county of Middlesex, civil engineer, for their having found out and invented an improvement or improvements on certain mechanical apparatus applicable to the raising of water, and other useful purposes.—15th November.—6 months.

To Arthur Howe Holdsworth, of Dartmouth, in the county of Devon, for his having invented improvements in the construction of rudders, and in the application of the same to certain descriptions of ships or vessels.—19th November.—6 months.

To David Selden, of Liverpool, in the county palatine of Lancaster, merchant, in consequence of a communication made to him by a certain foreigner residing abroad, for an invention of an improved carding and slubbing engine for wool, and other fibrous substances.—22nd November.—6 months,

CELESTIAL PHENOMENA, FOR DECEMBER, 1831.

D.	H.	M.	S.		D.	H.	M.	S.	
1	0	0	0	☉ before the Clock 10 min. 55 sec.	16	10	0	0	☽ in conj. with ϵ in Taurus
1	6	0	0	☽ in conj. with δ in Oph	17	5	0	0	☽ in conj. with γ in Taurus
1	22	0	0	☽ in conj. with B in Oph	17	6	0	0	☽ in conj. with 1δ in Taurus
2	6	0	0	☾ in conj. with γ in Libra	17	7	0	0	☾ in conj. with 2δ in Taurus
3	19	48	0	Ecliptic conj. or ☉ new m.	18	12	0	0	♂ in conj. with λ in Libra
5	0	0	0	☉ before the Clock 9 min. 20 sec.	18	13	0	0	♂ in conj. with \downarrow in Sag.
5	11	0	0	☽ in conj. with 1μ in Sag.	18	17	10	0	Eclip. oppon. or ☉ full m.
5	12	0	0	☽ in conj. with 2μ in Sag.	19	5	0	0	☾ in conj. with ν in Gemini
5	20	0	0	♃ in conj. with δ in Caps.	20	0	0	0	☉ before the Clock 2 min.
6	14	0	0	☽ in conj. with π in Sag.	21	9	0	0	☾ in conj. with δ in Cancer
8	22	0	0	☽ in conj. with η lon. 12. in Cap, ☽ lat. 12 N. η lat. 40 S. diff. of lat. 52	22	1	6	0	☉ enters Capricornus
9	11	0	0	☽ in conj. with γ long. 18, in Cap. ☽ lat. 26 S. γ lat. 56 S. diff. of lat. 30.	22	18	0	0	♂ in conj. with 1 and 2 B in Scorpio
10	0	0	0	☉ before the Clk. 7 m. 9 sec.	24	2	0	0	♃ Stationary with σ in Leo
11	0	0	0	♂ in conj. with λ in Sag.	24	2	0	0	☾ in conj. with η long. 13 in Leo. ☾ lat. 2 38 N. η lat. 1 54 N. diff. of lat. 41.
11	2	0	0	♀ in conj. with κ in Virgo	25	0	0	0	Clock before the ☉ 8 sec.
12	23	22	0	☽ in ☐ or first quarter	25	12	10	0	☾ in ☐ last quarter
14	12	0	0	♂ in conj. with κ in Libra	29	12	0	0	☾ in conj. with γ in Libra
15	0	0	0	☉ before the Clock 4 min. 48 sec.	30	0	0	0	Clock before the ☉ 2 min. 26 sec.
15	4	0	6	♂ in conj. with σ in Sag.	30	17	0	0	♀ in conj. with 4 ξ in Libra
15	8	0	0	☽ in conj. with 2 ξ in Ceti					

J. LEWTHWAITE
Rotherhithe.

The waxing moon ☽.—the waning moon ☾

Barley's Improved Loom Machinery

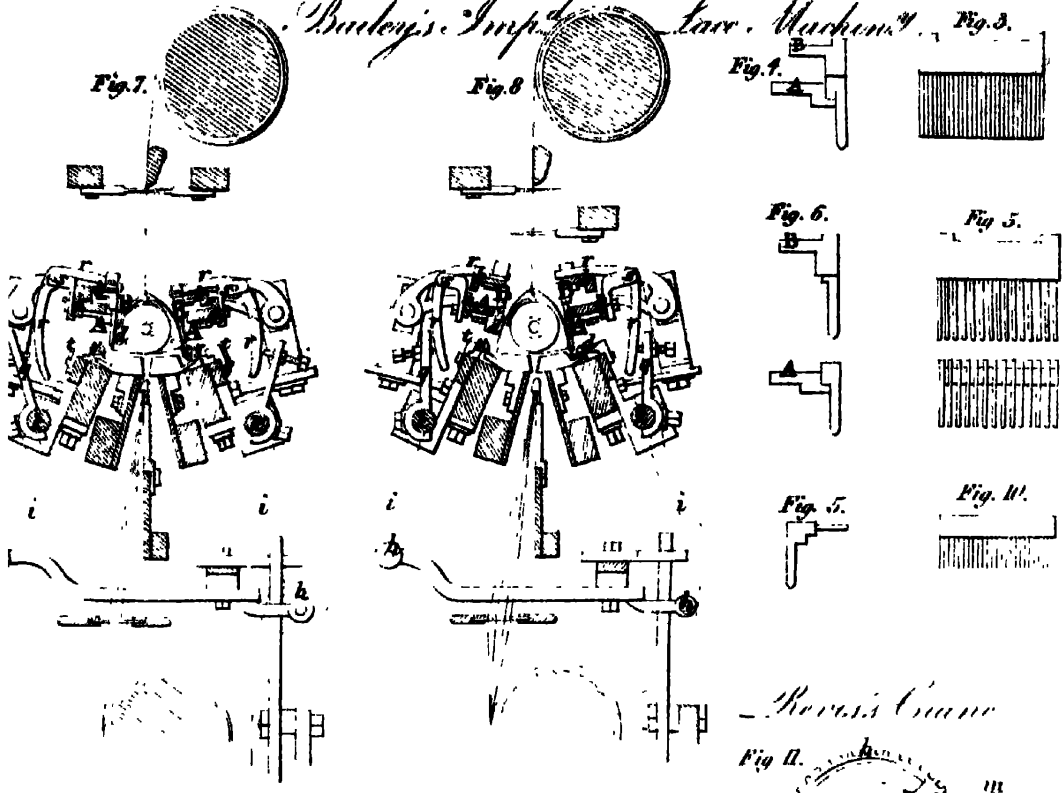

Lucas's Improved Propelling

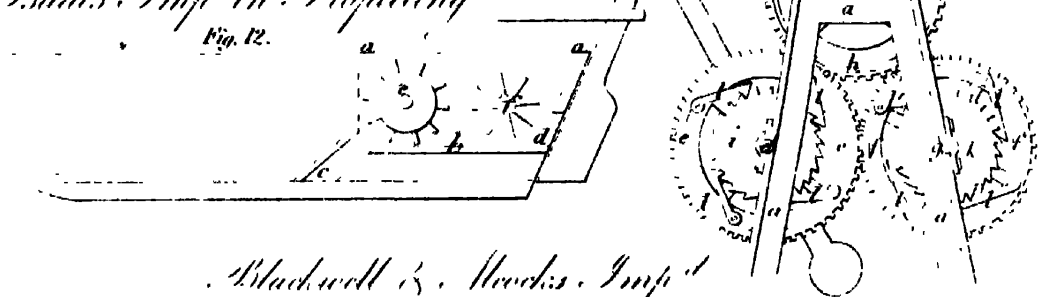

Blackwell & Hooker's Improved Loom Machinery

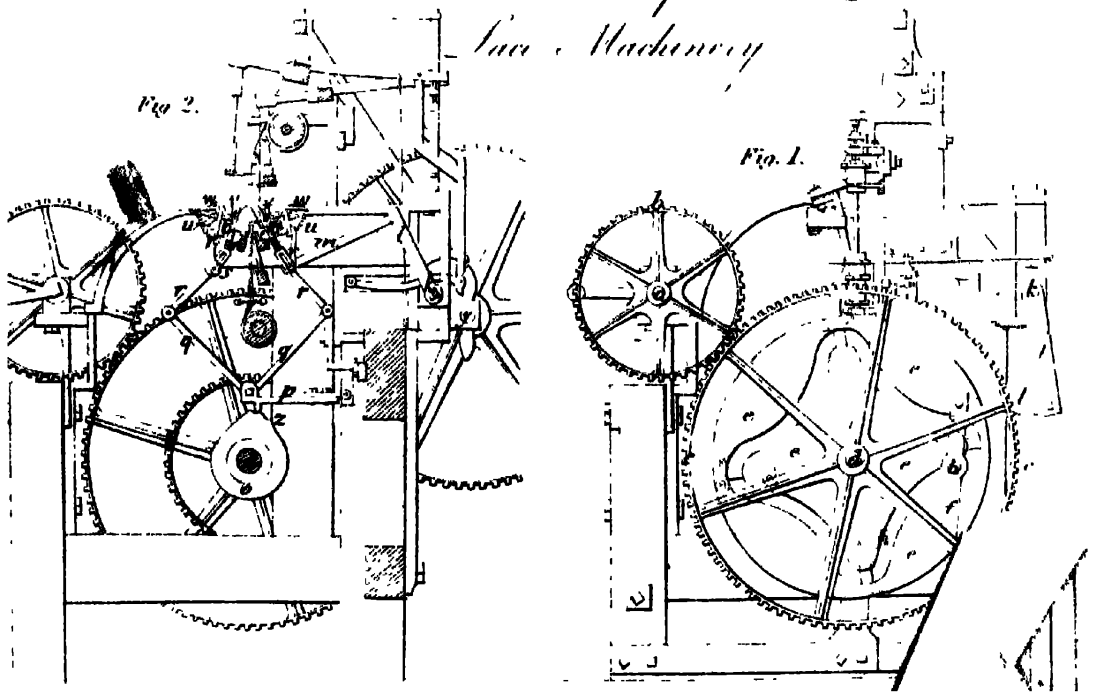

•

,

Howards Steam Boiler

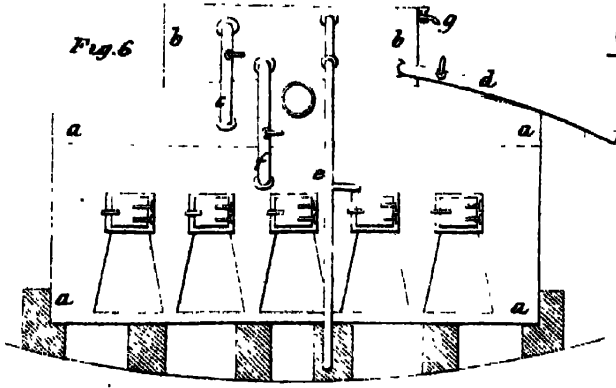

*Piton & Vardys
Imp'd Cook*

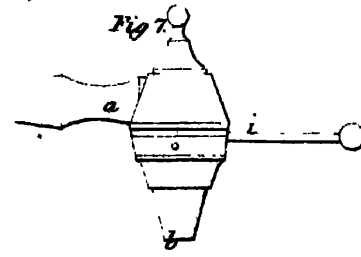

Rennies Friction App^{ts}

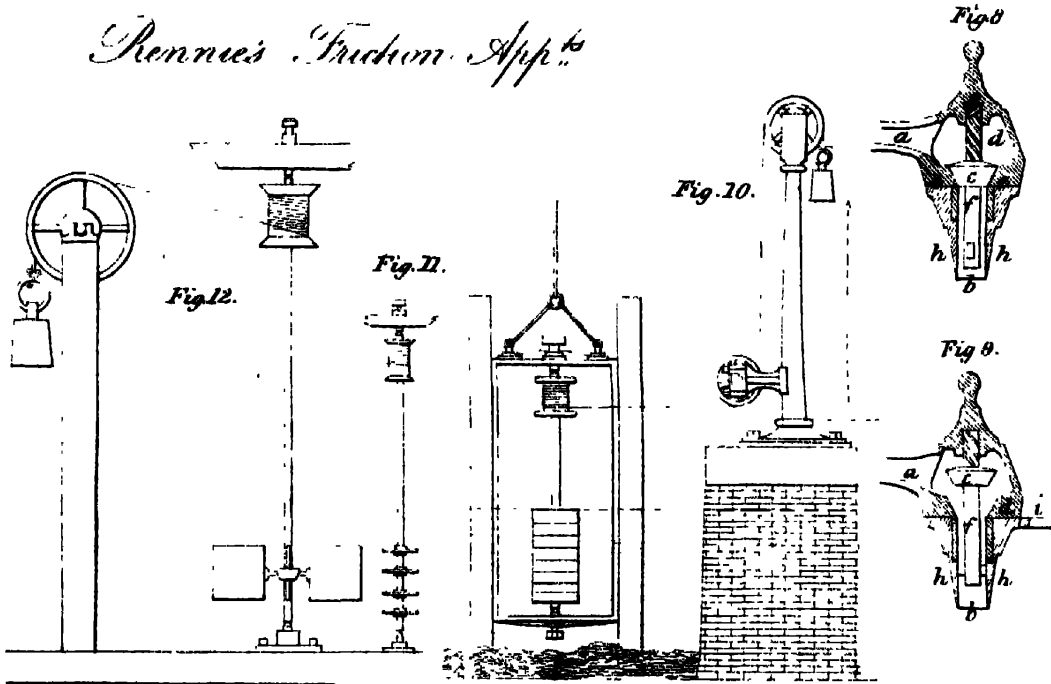

Spencey's Gas Valve

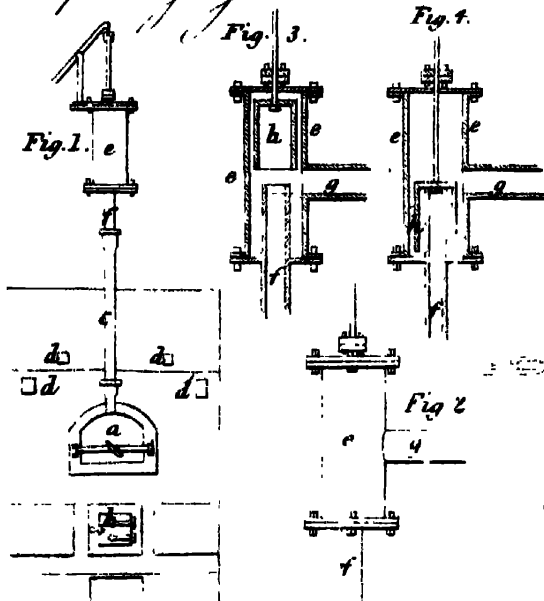

Young's Windlofs

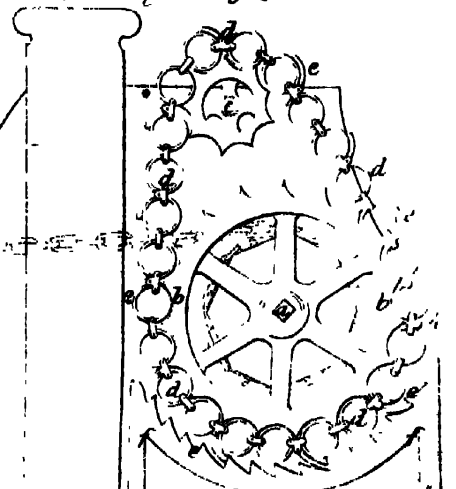

THE
London
JOURNAL OF ARTS AND SCIENCES.

No. XLVI.

[SECOND SERIES.]



Recent Patents.

To JOHN BLACKWELL and THOMAS ALCOCK, both of Claines, in the county of Worcester, machine makers and bobbin-net manufacturers, for their having invented or found out certain improvements in machines or machinery for making lace, commonly called bobbin-net.—[Sealed 13th January, 1831.]

THESE improvements apply to that particular kind or construction of machinery for making lace, commonly called or known by the name of the *Lever's principle*, which machines are by the Patentees intended to be worked by the agency of a revolving shaft, driven by the hands of the workman, or by any other suitable rotatory power.

The improvements consist in the following contrivances, (viz.) first, a new method of working the landing bars of the machine, by means of certain vibrating levers, and connecting rods actuated by a revolving cam, or excentric roller; or a sort of zigzag or excentric groove, formed in the face of a wheel or

revolving plate : and, secondly, a new method of working the dividing bars or pusher bars, by means of compound levers on the lazy tongs principle, which are actuated by a revolving cam, connected to the driving part of the machine. These objects will be fully understood by every person conversant with the construction and operation of the *Lever's Machines*.

To render these contrivances perfectly evident, the Patentees have subjoined drawings to their specification, exhibiting their inventions in several figures, shewing the connection of the new and the old parts, and the manner in which they act together.

Plate VIII. fig. 1, is the right hand end elevation of a Lever's machine, with the improvements adapted thereto. Fig. 2, is a vertical section, taken transversely through the machine, at about two feet from the right hand end.

The several letters of reference indicating the same parts of the machine in all the figures; *a, a*, are two short axles, mounted on standards on the front parts of the wood frame, towards the end of the machine; to these axles, which are concentric with each other, the driving handle is attached, and by the rotation of these short axles, all the movements of the machine are effected. At the outer extremity of each of the short axles, *a, a*, a toothed wheel, *b, b*, is affixed; which respectively take into larger toothed wheels, *c, c*, upon the ends of the main shaft *d, d*; this axle *d*, extends horizontally along the whole length of the machine; it is therefore by the connection of this toothed gear that this main shaft is driven.

Towards the right hand end of the main shaft, near its extremity, the wheel *e*, with the excentric or zigzag groove is affixed, for the purpose of working the landing bars as above said. This wheel is best seen in the end view, fig. 1. Contiguous to the zigzag wheel, a vertical lever *f*, is mounted upon a fulcrum pivot *g*, which enables it to vibrate. In the side of this lever, a pin is fixed, which carries a friction roller *h*, that

works in the excentric or zigzag groove of the wheel *e*, and consequently as the wheel goes round, the lever *f*, vibrates to and fro. At the upper extremity of the lever *f*, a short rod *i*, connects the said lever to the crank arm *j*, fixed on the end of a horizontal shaft *k*, which extends nearly half way along the back part of the machine. At the reverse end of this shaft *k*, another crank arm *l*, is fixed, seen in the section, fig. 2.; which, by means of a rod *m*, is connected to the back landing bar *n*, (that and the front landing bar being connected together by the ordinary goose-necked tackle.) Hence it will be perceived, that the vibrations of the lever *f*, actuated by the zigzag grooved wheel *e*, give those successive movements to the landing bars, which in ordinary Lever's machine are effected by the workman raising the handles affixed to the front landing bars; the object and effect of which is so well understood, that no further explanation is deemed necessary.

Upon the main shaft *d*, near the centre of the machine, the cam or excentric roller *o*, is fixed; see the section fig. 2. On the periphery of which a tooth *z*, extending from the under part of a lever *p*, is intended to work as the cam goes round; this is for the purpose of moving the pusher bars, which divide the bobbin carriages, after every fourth stroke of the landing bars, an operation which, in ordinary Lever's machine is performed by the foot of the workman pressed upon a treadle below. From the acting extremity of the lever *p*, two rods or arms *q*, *q*, extend, and at their upper ends are jointed to bent levers *r*, *r*, *r*, *r*, which have their fulcrums *s*, *s*, on the same axes as the pusher bars *t*, *t*. The pusher bars necessarily rise and fall with the landing bars, as in ordinary Lever's machines, but it is only after every fourth stroke of the landing bars, that the pushers are to be brought into operation. This is effected when the elevated part of the cam *o*, comes round as shewn in fig. 2, at which time the lever *p*, is raised, and with it the rods *q*, *q*, which expand the joints at the tails of the bent levers *r*, *r*, and cause their upper ends at *u*, *u*, to press against

the backs of the pusher bars, and force the pushers in : by which means the carriages are divided. This takes place at the time that the landing bars are finishing their fourth stroke.

The particular form in which we recommend the cam *o*, to be made, is shown in fig. 3. When the tooth *s*, of the lever *p*, has risen to the highest point of the cam *o*, it passes down the first short inclined plane, for the purpose of bringing the ends *u, u*, of the levers *s, s*, gently into contact with the pusher bars, in order to avoid concussion ; and when the ends of the levers have been thus brought into contact with the pusher bars, as the tooth *s*, travels upon the small concentric segment of the cam, the joints of the levers *q, r*, remain nearly stationary, and the pushers are pressed in to divide the carriages by the closing of the landing bars.

At this time the two catch bars *v, v*, falling into the ears of the bobbin carriage, for the purpose of locking them, as it is commonly called, it is necessary to ease its descent, in order to prevent concussion, which we do by the employment of a small apparatus, acting under each of the catch bars, as shewn at *w, w*, fig. 2, which resembles a pair of pliers or the bills of a duck. The lower chap is fixed to its standard, the upper one opens upon a joint, having a lever tail with a helical spring, acting to keep the chaps open ; one of each of these apparatus are mounted upon each of the pusher bars, and when the pushers are pressed in to divide the carriages, the nose of each of these pliers are carried under the catch bars, and when the catch bars fall as above said, the upper chaps of the open bills receive them, and allow of their descending gently by the resistance of the springs ; and then, by resting upon the closed bills, are prevented from falling upon the pushers, which lie under them. When the bills *w, w*, have by these means become closed, the time has arrived for the tooth *s*, to pass down the second inclined plane of the cam *o*, which causes the joints of the levers *q, r*, to descend, and allow of the pusher bars

drawing out from under the catch bars, which is effected by helical springs adapted to each of the pusher bars, in the same way as the back pusher bar is drawn back in the ordinary Lever's machine. It is necessary that the landing bars should be stationary at the time that the pushers are drawn from under the catch bars; and in order to effect this, a portion of the cam or zigzag groove of the wheel *e*, is removed or cut away, as shewn at *x*, in fig. 1, which allows the wheel to turn through a small part of its rotation without moving the lever *f*. This point of the cam or zigzag wheel *e*, is made shorter than the other three, in order that the landing bars at this time may only go in as far as the locking place in the ordinary Lever's machine.

The working of the point bars is effected by the rotation of the small toothed wheel at the left hand end of the main shaft *x*, which drives a large wheel on the back horizontal shaft *y*. This shaft has two wipers acting against the ends of the pusher levers, which lift the tail poles of the point bars, as shewn in the section fig. 2.; but this part of the machine is not claimed, as the invention is stated to consist in the new method or mechanism for working the landing bars and the pusher bars, as above described.—[*Inrolled in the Rolls Chapel Office, July 1831.*]

Specification drawn by Messrs. Newton and Berry.

To GEORGE JOHNSON YOUNG, of the town and county of Newcastle-upon-Tyne, iron founder, for his invention of a machine, whereby an additional and improved purchase or power will be given in working ships' windlasses and capstans.—[Sealed 21st June, 1828.]

THE proposed improvement consists in connecting to the barrel of the windlass or capstan a pair of wheels of dissimilar diameters, and applying the actuating power

to the axle of the lesser wheel, by which an increase of power is communicated to the barrel that the cable is to be wound upon, though of course at the expense of time. This does not appear in itself to possess any novelty, but we presume that the Patentee considers his invention to consist principally in the mode of gearing the two wheels together, which is by an endless chain passed over the periphery of two star wheels, the links of the chain taking hold of the points and indentations of the star wheels instead of teeth taking into each other as in ordinary tooth and pinion gear.

In Plate XI. fig. 5, is an end view of a windlass turning upon its axle *a*, mounted in wooden standards. Upon the end of the axle of the windlass, the large star wheel *b*, is affixed. A smaller star wheel *c*, is mounted upon an axle above, and over the periphery of both wheels the endless chain *d, d, d*, passes. The chain is formed by circular rings, connected together by flat links, and the rings are made to fit into the cavities of both the star wheels, the points of the stars of course falling into the links between the rings.

On applying the power of the men, either by handspikes or winch, to the axle of the lesser wheel *c*, that wheel will be forced round, and the chain with it, and consequently cause the chain to draw the larger wheel *b*, which gives rotary motion to the windlass.

To every alternate link a pall *e, e, e*, is attached, which, passing round with the chain, come into operation in the segment rack *f, f*, below, and prevent the windlass from recoiling as it draws up the cable and anchor.

A similar contrivance to that above described is also proposed to be adapted to a capstan, but of course the wheels must, in that case, be placed in horizontal positions. Two horizontal wheels of equal diameter, turning

on stationary axles, are made to carry an endless chain, constructed of circular rings and flat links as above described; these rings and links, as they go round the wheels, are made to take hold of the points and recesses formed in the interior of an escolloped ring attached to the lower part of the capstan barrel. By applying the power of the men to one of the wheels described, the chain will be made to drag round the barrel of the capstan with an increased power to that applied, but of course with a slower motion than that of the actuating wheel.

It is scarcely necessary to add, that when a capstan or windlass is required to exert only an ordinary power, the handspikes of the seamen are to be applied immediately to the capstan-head or barrel of the windlass, and the effect will be the same as if the improved machinery were not connected to it.—[*Inrolled in the Inrolment Office, December, 1828.*]

To JOHN BURGIS, of Maiden Lane, in the parish of St. Paul, Covent Garden, and county of Middlesex, ornamental paper manufacturer, for his new invented method or methods of gilding or silvering certain woven fabrics in burnished, or burnished and dead or metted gold or silver, and which said fabrics may be used as gold or silver and lace borderings, and for other purposes.—[Sealed 5th February, 1829.]

THE very great expense of gold and silver lace, has induced the Patentee to invent a simple and cheap mode of manufacturing an imitation of that costly material, which he proposes to employ in decorating curtains, chairs, and other articles of household furniture. The material to be employed is fine cotton or other cloth, upon which a coating of gold or silver leaf is to be laid, by the ordi-

nary process of gilding and silvering. The cloth is then to be cut into narrow strips, and wound round cords to resemble cords of gold, which cords may then be plaited or otherwise woven into lace of various kinds. ●

The cloth about to be operated upon is first dried (if for gold of an orange or yellow colour). It is then to be stretched out upon a flat surface, and covered with a coating of size made of parchment shavings, in the same way that gilder's size is commonly made. When dry, the reverse side of the cloth is to be sized in the same way.

After this preparation, two or three coatings of the material called gold size, is to be laid upon that surface of the cloth which is intended to be gilt; this size being made of glutin, with pipe clay and ochre, or other yellow colour. When the materials have become perfectly dry and hard, the surface is to be polished smooth, and all hairs or small pieces of grit removed.

The cloth being tightly distended upon a flat surface, is now to be sponged over with water, and then the leaf gold laid on smoothly with a gilder's camel hair brush, taking care that all the fractured parts of the gold leaf are afterwards carefully covered with fresh pieces of gold leaf, so as to leave no parts of the surface ungilt.

When the gilding has become perfectly dry and hard, the cloth may be passed over a roller, and brushed, for the purpose of burnishing its surface; and if it has been gilt on both sides, that part of the cloth which is undermost should be carefully covered with paper to protect it from injury while under the operation of the burnishing brush. But when dead gold is required, then the burnishing brushes may be dispensed with.

The cloth having been thus gilt, is then to be cut into strips of any required width, in a machine, with knives or shears placed at suitable distances, in order that the strips

may be perfectly parallel. These strips are then to be wound or bound round cords of suitable thicknesses, the cords having been previously dyed of an orange or yellow colour; and the cords, after having been so covered with the gilt cloth, may be twisted together to represent bullion, or in any other way plaited or woven in the manner that gold lace is commonly made. Precisely the same operations are to be performed in the preparation of silver lace.

This artificial gold or silver lace may be applied as cording or bindings for the edges of chairs, sofas, &c. or for the fringe of curtains and other drapery.—[*Inrolled in the Inrolment Office, April, 1829.*]

To THOMAS REVIS, of Kennington-street, Walworth, in the county of Surrey, watchmaker, for his invention of an improved method of lifting weights.—[Sealed 10th July, 1828.]

THE object of the Patentee appears to be that of converting a reciprocating lever action into a rotary motion; but as to the advantages anticipated by this particular arrangement of machinery the Specification is silent, and we are at a loss to discover either novelty or utility in the plan proposed.

Plate VIII. fig. 11, represents an end elevation of the machine intended to be employed as a crane for lifting heavy weights; *a, a, a*, is one of the forked standards or end framework of wood or iron, upon which the axles and wheels are mounted; *b*, is the barrel that receives the draft rope; *c*, a lever to actuate the machinery, having a counter poise or balance weight at the end of its shorter arm.

The lever *c*, is affixed to the axle *d*, and when raised and depressed gives reciprocating rotary action to the axle *d*. The toothed wheel *e*, slides loosely round upon the axle *d*, and a similar toothed wheel *f*, slides also loosely round upon the axle *g*, the teeth of these two wheels *e*, and *f*, taking into each other, and also into the teeth of the upper wheel *h*, fixed on the end of the barrel *b*. At the reverse end of the machine there is affixed to each of the axles *d*, and *g*, a toothed wheel, exactly corresponding with *e*, and *f*, and the teeth of which likewise take into each other. It will hence be perceived, that on depressing or raising the lever *c*, the axle *d*, will be made to turn with a reciprocating action, and through the intervention of the toothed wheels last described, fixed at the further ends of the axles *d*, and *g*, both those axles will be made to turn simultaneously.

Upon each of the axles *d*, and *g*, there is also affixed a ratchet wheel *i*, and *k*, and palls or clicks *l*, *l*, *l*, *l*, which hang upon pivots set in the rims of the loose wheels *e*, and *f*, take into the teeth of these ratchet wheels. Now, on the lever *c*, being depressed, the axle *g*, and with it the ratchet wheel *i*, will be made to turn part of a rotation, as shewn by the arrow, and the teeth of this ratchet wheel taking hold of the clicks or palls *l*, attached to the loose wheel *f*, drag that loose wheel round with it, and cause the upper wheel *h*, on the end of the barrel *b*, to turn also, and hence to wind upon the barrel the rope *m*, to which the weight intended to be raised is supposed to be appended. On raising the lever *c*, the wheels will of course turn in reverse directions, the ratchet wheel *k*, the teeth of which before slipped over the ends of the palls *l*, affixed to the rims of the loose wheel *e*, will now take hold of the palls, and drag the wheel *e*, round with it, and cause the wheel *h*, again to turn, and thus to con-

tinue winding up the rope *m*, by which the weight is raised.

Hence, by the continued reciprocating action of the lever *c*, the barrel winds up the rope and raises the heavy body.—[*Inrolled in the Inrolment Office, January, 1829.*]

To THOMAS SPINNEY, of Cheltenham, in the county of Gloucester, gas engineer, for his invention of certain improvements in apparatus for manufacturing gas for illumination.—[Sealed 2d June, 1831.]

THESE improvements in manufacturing gas for illumination, consist in the adaptation of a valve to the ascension pipe leading from the retort or brick oven in which the gas is generated. The object of this valve is to supersede the employment of an hydraulic main, and thereby to take off the pressure to which the gas has hitherto been subject in passing through the hydraulic main. The advantages attendant upon thus removing the pressure are two-fold; firstly, a considerable increased durability of the retort or oven; and secondly, a much larger quantity of gas obtained from whatever material may be used for the production of gas for illumination.

In order to render these improvements in the manufacture of gas evident, drawings exhibiting the construction and mode of adapting the valve to the ascension pipe, employed for the above purpose, are appended to the Specification.

Plate XI. fig. 1, is a front view of a brick oven to be used as a retort for generating gas; *a*, is the mouth of the oven; *b*, the fire door; *c*, the ascension pipe; *d, d, d*, sight holes for examining and cleaning the flues; *e*, is the valve-box, placed upon the ascension pipe; fig. 2, is a

side view of the valve detached from the ascension pipe, and upon a larger scale ; figs. 3 and 4, are vertical sections of the same ; *f*, is the lower pipe through which the gas passes from the ascension pipe into the valve or box ; *g*, is the lateral pipe by which the gas proceeds to the purifiers ; *h*, is the cylindrical cap or cover, which is made to move up and down by means of its rod passing through a stuffing box ; *i, i, i*, is a reservoir of water, tar, or any other liquid, in the lower part of the valve-box, into which the cylindrical cap or cover *h*, descends for the purpose of shutting off the passage of the gas. In fig. 3, the cap or cover *h*, is raised, which allows the gas to pass freely from the generator to the purifying vessels and gas-holder ; fig. 4, shews the cap or cover dropped down into the reservoir *i, i*, which effectually shuts off all communication between the gas-holder and the retort or oven.

The Specification concludes by saying, I have exhibited in the drawing accompanying this Specification, such a form and construction of valve as fully answers the above purpose ; but I do not intend to confine myself to that particular form or construction, as my invention consists in the adaption of a valve, of any suitable construction, to the ascension pipe of a gas retort, oven, or generator, for the purposes of superseding the necessity of the hydraulic main hitherto used.—[*Inrolled in the Rolls Chapel Office, August, 1831.*]

Specification drawn by Messrs. Newton and Berry.

To JOHN JOHNSON ISAAC, of Star-street, Edgware Road, in the county of Middlesex, engineer, for his invention of improvements in propelling vessels, boats, and other floating bodies.—[Sealed 5th July, 1828.]

THE Patentee proposes by this invention, to propel vessels without subjecting the water on which they float to

any considerable degree of agitation, to render such vessels much more buoyant than those of the ordinary construction—to prevent their rolling or heeling when in a rough sea, and so to inclose the propelling machinery, that it shall be less liable to accident than in the usually exposed situations of the paddle wheels at the sides of ships.

In order to effect those objects, the stern part of the vessel is to be elongated; that is, the sides are to be continued for some distance beyond the ordinary stern, for the purpose of constructing a compartment capable of containing the propelling wheel; which compartment is to have an open channel at the fore end, for the admission of the water, and also an opening at the hinder part, for its discharge.

Plate VIII. fig. 12, is a longitudinal section of a vessel, *a, a*, being the elongation at its stern; *b*, is a false bottom or partition forming the under part of the compartment; *c*, is the channel through which the water passes into the compartment, and *d*, is the opening at which it is to escape; *e*, is the paddle wheel, formed by an air-tight drum, with float boards or radial paddles fixed round it. The ends or pivots of the axle of this propelling wheel turn in long grooves or slots in the sides of the compartment, in order that the wheel may be raised or lowered according to the draft of the vessel, so as to dip a certain depth only into the water, however little or much water the vessel may draw; and this contrivance will allow of the wheel being drawn up altogether out of the water, in the event of the vessel being propelled by sails alone.

In order that this wheel may be uniformly turned by the impelling power of the engine within, it is proposed to drive it by chains passed over spur wheels upon its axle instead of toothed gear, as in ordinary steam vessels.

The compartment, *a*, *a*, being closed on the sides, it is considered, that the agitation of the water caused by the rotary action of the paddles will be restrained, and that it will flow out behind in a smooth current ; to assist which, a wheel *f*, with many arms, is placed within the compartment near to the paddle, for the purpose of breaking the surf of the tail water, thereby enable the propelling wheel to be employed on canals.

It is also considered, that when steam vessels are exposed to very rough sea, the elongation at the stern and the enclosure of the paddle wheel within the compartment will prevent the vessel from heeling or laying to, and cause it to pass through comparatively still water ; and the contrivance for raising the wheel will allow of its axle being raised or depressed on one side if necessary, so as to revolve parallel to the surface of the water, however much the vessel may incline from an erect position.

It is further stated, that the propelling wheel being formed of a hollow drum, which is made perfectly water-tight, that drum will constitute an air vessel, to assist in case of need in rendering the vessel buoyant ; and that buoyancy may be aided by filling all the vacant parts of the vessel, such as the recesses between the timbers and under the gunwales with small air vessels, cork or any other light or floating material ; and the sides of the compartment *a*, may be packed with such soft or flexible materials as shall resist external force, in order to protect the propelling machinery from gun-shots or other destructive weapons.

The Patentee acknowledges that the separate parts above described are not new, but he states that his claim of combination and arrangement, and consequently of beneficial effect resulting from their exclusive appropriation to which this patent entitles him, consists in the follow-

ing particulars. First, the peculiar construction of a buoyant vessel, which in being propelled by means of a paddle wheel shall so little disturb the water as to render it capable of being employed upon canals. Second, that a vessel so fitted up will be less effected by heeling or laying to, and will therefore be in comparatively still water, although the sea may be rough. Third, the machinery being enclosed and guarded by the elongated sides of the vessel, and which may be made shot and bomb proof, is less liable to accident in action.—[*Inrolled in the Inrolment Office, January, 1829.*]

To THOMAS, WILLIAM, and JOHN POWELL, of the city of Bristol, glass merchants and stone ware manufacturers, for their invention of certain improvements in the process and machinery, or apparatus for forming, making, or producing moulds or vessels for refining sugar; and, in the application of materials hitherto unused in making the said moulds.—[Sealed 17th May, 1828.]

THE Patentees propose to make the conical moulds or vessels in which refined or loaf sugar is moulded from stone ware clay, and to glaze them both within and without.

In the first instance, the stone ware clay is to be prepared in the usual manner, and is then to be put under a press, for the purpose of bringing it into a sufficiently stiff and compact consistency. In the bottom of the vessel in which the clay is pressed, a mould is placed, consisting of a flat board, with a broad conical aperture cut out of its centre. In this aperture of the board the clay is to be shaped, which is to form the vessel.

As the board lays flat under the press, the clay will necessarily be forced into the recess or aperture, which being done, it is then cut off level from the clay which is above it, by passing a wire or string, or thin cutting blade over the surface of the board, which leaves the portion of clay thus moulded in a thin slab of a broad conical form.

This slab of clay, while in its plastic state, is then placed round a conical block, so as to cover the block perfectly, and any small defects which may be left at the junctions of the edges of the slab are to be made up with small portions of clay laid on with a spatula or pallet knife.

The block is now set in a convenient situation, where the coating of clay may be dried by the air; and when it has become completely dry, the block is fixed upon a rotary spindle passed through its axis, and the outside of the clay vessel is turned perfectly smooth in the same way as stone ware articles are usually made.

The shell of clay being then slipped off its block, will be found to be an accurately formed conical vessel, having a small hole in its apex, and suited for the purpose of a sugar mould, perfectly smooth both within and without.

Any number of these conical vessels may then be placed upon their bases side by side, in an oven, for the purpose of being baked, and they are to be glazed within and without by salt, as clay stone ware is usually glazed.
—[*Inrolled in the Inrolment Office, July, 1828.*]

To THOMAS BAILEY, of Leicester, in the county of Leicester, frame-smith, and CHARLES BAILEY, of the same place, frame-smith, for their having invented or found out certain improvements in machinery for making lace, commonly called bobbin-net.—[Sealed 15th February, 1831.]

THESE improvements in machinery for making bobbin-net lace, apply to that particular construction of machinery known by the name of the *Lever's principle*, and consist in certain variations from the original mechanism of the Lever's machine, by means of which those parts of the mechanism called the pushers, the pusher-bars, and all the appendages heretofore employed in connection with those working parts which are called the dividing tackle, are altogether dispensed with: and the dividing of the bobbin carriages is effected by means of a peculiar construction of catch-bar about to be described, and the mode of working them. And in order to afford additional safety in working the Lever's machinery, and prevent any derangement of the bobbins and carriages by the vibrations of the machinery, when in rapid action, a simple contrivance is adopted, consisting of a series of small thin pieces of metal, resembling the elongated extremities of the ordinary combs, which pieces are mounted in leads as combs are usually mounted, and denominated conducters, as they are for the purpose of conducting and keeping the bobbin carriages apart, and preventing their shifting from their proper situations when at work.

As the construction of the ordinary Lever's machine is well known to lace-makers, and has been often explained in the pages of our Journal, it will be unnecessary to describe its operative parts; we shall therefore merely mention the several parts as they occur, by name, and

refer only to their uses, conceiving, that in so doing, the invention will be perfectly understood by all who are acquainted with the Lever's machine.

In the Lever's machines heretofore used, it was necessary, in dividing the bobbin carriages, to employ a series of fingers, called pushers, which, acting against every alternate carriage, forced those carriages out of the uniform range, in order that one-half of the carriages might be taken hold of and drawn out by the back catch-bar, and the other half by the front catch-bar, when the machine next opened. Instead of this contrivance, a compound catch-bar is constructed, consisting of a series of pieces of metal, which fit closely into the spaces between each other, and when combined, form a solid blade or bar, resembling in shape and appearance the blade of the ordinary catch-bar. Plate VII. fig. 3, is a front view of a pair of leads, with the pieces cast in them in the same way as ordinary pushers, or comb leads, forming when combined, a portion of the blade of a catch-bar; fig. 4, is a side or edge view of the same; fig. 5, represents front views of the two parts of the catch-bar blade detached; and fig. 6, edge views of the same; A, is that part of the compound lead which is to be fixed on to the ordinary catch-bar; B, is that part of the compound lead which is to be fixed on to another flat bar placed above the catch-bar. When these two parts are united, as shewn in figs. 3 and 4, they form the solid blade of the catch-bar, and then take hold of all the carriages, as shewn by the back catch-bar *c*, in fig. 7. This figure is a transverse section taken through the machine at the time when the bobbin carriages are all in one uniform range, and the machine is closed; fig. 8, is a similar section taken through the machine when the bobbin carriages are about to be divided.

In effecting the dividing of the carriage in the ordinary Lever's machine, it is first necessary to raise the catch bars out of the ears of the carriages, in order to allow the pushers to project every alternate carriage forward; but in the improved plan, the pieces *c*, are only raised, which constitute one half of each compound catch bar, while the pieces *d*, which constitute the other half of the compound catch bars, remain in the ears of the carriages, as shewn in fig. 8, observing that the pieces *d*, of the back catch bar, take hold of the ears of one half of the carriages, and the piece *d*, of the front catch bar, take hold of the ears of the other half of the carriages.

It will hence be seen that on the machine opening, the pieces or fingers *d*, *d*, both of the back and front catch bars, draw out those carriages on which they are respectively intended to act, and as soon as the ears of the carriages of one range have cleared those of the other range, the piece *c*, *c*, with the bars *b*, *b*, immediately fall down, and form solid catch bars, as figs. 3, and 4, and consequently take the respective ranges of carriages to their destination, ready to be shogged, as in the ordinary operations of Lever's machines.

The construction and effect of these compound catch bars having been explained, the Specification proceeds to point out the means by which they are worked, to produce the rising and falling of the separate parts of the compound catch bars above described.

The vibratory actions of opening and closing the machine being effected, either by the ordinary handle in front, or by the rotatory apparatus through the agency of cranks and rods, the catch bar-wheels or tappets (which are placed in the middle of the machine) raise the catch bars as usual, except at the times of dividing the carriage, when a small piece *h*, figs. 7, and 8, called a stop,

slides behind the small lever *i*, affixed to the longitudinal rod *k*, *k*, *k*, one of which hangs in front of each landing bar, and as the machine closes, this stop *h*, pushes the lever *i*, outwards, causing the rod *k*, to be turned round a little distance upon its axis, as will be seen by reference to the dotted lines in the last-mentioned figures.

In order to slide the stop *h*, in a lateral direction, for the purpose of bringing it immediately behind the lever *i*, as above mentioned, a cam wheel is affixed upon the main shaft of the machine, which, as it revolves, causes a lever to be raised once at every fourth vibration of the machine, and to lift a rod which projects the slider that carries the stop *h*, into the required situation, behind the lever *i*, while the machine is open.

It will now be seen, by reference to fig. 8, that on the closing of the machine the levers *i*, *i*, strike against the stops *h*, *h*, and are consequently forced outwards, and that the rods *k*, *k*, to which the levers are affixed, turn round a short distance upon their axes, and thereby cause the small erect levers *q*, *q*, also fixed to the rods *k*, *k*, to strike against the lower arms of the elbow lever *r*, *r*. These elbow levers have their fulcrums or pivots in the small studs or standards *s*, *s*, affixed to the lower catch bars *a*, *a*, and when the lower arms of the levers *r*, *r*, are pressed inwards by the means described, the upper arms of the said levers passing into staples on the top of the upper end of the catch bars *b*, *b*, raise the bars, lifting up the parts *c*, *c*, of the compound catch bar blade, as shewn in fig. 8.

By these means every alternate bobbin carriage is released from one of the catch bars, one half of the carriages being held by the parts *d*, of the catch bar in front of the machine, and the other half of the carriages by the parts *d*, of the catch bar at the back of the machine.

The opening of the machine now causes the carriages to divide, and by the time that one range of the carriages have passed the ears of the other range, the tails of the levers *i, i*, having receded from the stops *h, h*, the upper catch bars *b, b*, are allowed to fall, and to form the compound bars *c, d, c, d*, into solid blades, as fig. 4, which bars then perform the functions of ordinary catch bars, as in the usual construction of Lever's machine.

On the three next openings and closings of the machine, the stops *h, h*, will stand free of the levers *i, i*, and the compound catch bars will then act with solid levers, as in ordinary machines; but on the fourth opening and closing of the machine, the stops will come into operation, and produce the effect of lifting the parts *c*, of the compound catch bars in the way described.

We now proceed to describe the carriage conductors, which are employed for the purpose of keeping the carriages steady, and preventing them from being forced into wrong gates or spaces between the combs, by any shaking or extraordinary vibration of the machine when in rapid motion. Fig. 9, is a side view of one of the leads *t*, holding a series of thin pieces of metal *v*; fig. 10, is a top view of the same. The leads of these carriage conductors are attached to the landing bar, as shewn in the sectional figures 7, and 8, with the ears of the carriages resting between them, in which situations they always remain during all the evolutions of the machine.

The Specification concludes by saying, "Lastly, we desire it to be understood, that our claim of invention and improvement upon machinery for making lace, commonly called bobbin net, consists in the construction of the compound catch bars, and the carriage conductors, as above described, and the adaptation of the same to such machines for making lace as are commonly called

or known by the name of Lever's principle."—[*Inrolled in the Rolls Chapel Office, August, 1831.*]

Specification drawn by Messrs. Newton and Berry.

To JOSEPH CLISILD DANIELL, of Stoke, in the parish of Bradford and county of Wilts, clothier, for certain improvements applicable to the manufacturing and preparing of woollen cloths.—[Sealed 5th August, 1828.]

THERE are two objects proposed under this patent ; the first is designed to preserve a uniform tension in the warp threads of a cloth loom, the second, to give additional force to the beaters of a stock for fulling cloth.

In the first instance, the loom is not intended to be altered in its general construction from ordinary looms for weaving cloth, but there is affixed to the end of the warp roller a pulley, over which a weighted cord is passed for the purpose of drawing the warp tight, and at the same time allowing it to be given out as the batten beats up the work. A similar pulley is also attached to the end of the work roller, with a weighted cord passed over it in the opposite direction to the former, in order to draw up the work. Hence, the warp threads are always kept at a uniform tension, and when any additional force is exerted as in beating up, a small portion of the warp only is given out, by the roller slipping round under the weighted cord.

The second feature of the invention applicable to fulling stocks, is designed to supersede the present mode of allowing the beaters to fall from a height by their own gravity, and to effect the beating and milling

of the cloth by their descent. Instead of this, it is proposed to raise the beaters but a short distance up from the cloth in the cell of the stock, and to give forcible effect to their descent by means of powerful springs acting at the back of the arms of the beaters.

The adaptation of springs to the backs of the beaters, for the purpose above stated, may be effected in various ways, and by several kinds of springs, all of which the patentee claims as coming under his invention, and the advantages anticipated are that considerable time may be saved in the performance of the fulling or milling process, by shortening the stroke of the beaters which will allow of a much more frequent repetition of the blows than when the beaters are allowed to fall from a height, and the power of the spring upon the improved plan may be made to give an equally effective blow to that produced in the ordinary stock by the descent of the beaters from gravitation.—[*Inrolled in the Inrolment Office, February 1829.*]

To SAMUEL SEAWARD, of the canal iron works, in the parish of All Saints, Poplar, and county of Middlesex engineer, for his having invented an improvement or improvements in apparatus for economizing steam, and for other purposes ; and the application thereof to the boilers of steam engines employed on board packet boats and other vessels.—[Sealed 15th January, 1831.]

THE subject of this patent is the adaptation of a box or vessel contiguous to the boiler, which is either to be employed to receive and condense the surplus steam usually blown away at the safety valve of the boiler, when

the pressure of the steam has arisen to an extraordinary height, or by producing a vacuum in this box to draw or pump water from the hold of the ship, or from the sea, for the supply of the boiler ; in both of which cases a saving of fuel is effected.

Plate XI. fig. 6, *a a a*, represents the front elevation of a boiler for a steam vessel ; *b b*, is the box or vessel above mentioned, placed upon it, called a receiver, which should be made equally as strong as the boiler, in order to resist the pressure of the steam, and of about one twentieth of the capacity of the water chamber within the boiler. This receiver is most conveniently situated when placed upon the top of the boiler, as in that situation the water contained in it will more readily descend into the boiler by its own gravity.

To this receiving vessel *b*, there is attached four pipes with stop cocks. The pipe *c*, proceeds from the upper part of the receiver to the steam chamber of the boiler ; the pipe *d*, from the lower part of the receiver to the water on the outside in which the ship floats ; the pipe *e*, from the top of the receiver down to the bottom of the hold of the ship ; and the pipe *f*, from the bottom of the receiver to the water chamber of the boiler.

When the steam has acquired so much pressure as to raise the safety valve and escape, either in consequence of the engine standing still, or by an extraordinary quantity of heat emitted from the furnace ; the stop cock of the pipe *c*, is to be opened, when the receiver will be filled with steam ; the air escaping by a discharge cock at *g*. On the receiver having become filled with steam, the stop cock of *c*, is to be closed, and also the discharge cock *g*, and the cock of the pipe *d*, opened when the steam will immediately become condensed within the receiver, and a partial vacuum being thereby formed,

the water will then rush from the outside of the ship, and fill the receiver. The cock of the pipe *d*, is then to be closed, and that of the pipe *f*, opened, when the water will descend slowly into the boiler by its own gravity, and at a temperature very little below the boiling point.

By this operation it is considered a saving of fuel will be effected, because at all times the boiler may be completely filled with water which has been heated by the steam that would in the ordinary way have escaped to waste, and even to the annoyance of the passengers on board.

The operation of drawing water from the hold of the ship by means of this improved apparatus is equally simple ; let the stop cock of the pipe *c*, be opened and the receiver *b*, by that means be filled with steam as before, then on closing the cock *c*, and opening that of *e*, the steam will become condensed, and the water from the hold rush up the pipe, into the receiver, from thence it may be discharged over board, by opening the cock of the pipe *d* ; this operation may be repeated until the ship's hold is perfectly dry. Fifty or sixty tons of water every hour may be by these means discharged with ease from a ship carrying an engine of about one hundred horse power, by simply employing the spare steam when the engine is at rest.

The Patentee concludes his Specification by saying, that he claims the above contrivance when applied to the boilers of steam engines employed on board packet boats, and other vessels, for the purpose of economising steam, but not when employed for other purposes.—
[*Inrolled in the Petty Bag Office, July, 1831.*]

To PEREGRINE PHILLIPS, Jun. of Bristol, vinegar maker, for his invention of certain improvements in manufacturing sulphuric acid, commonly called oil of vitriol.

[Sealed 21st March, 1831.]

THE Patentee commences his Specification by describing the old mode of making sulphuric acid, by way of introduction to the explanation of his new process.

Sulphuric acid, or oil of vitriol, is generally made by the combustion of sulphur and saltpetre, either mixed together in large chambers or leaden vessels, or separately in ovens connected with leaden vessels, into which a greater or less portion of atmospheric air is admitted. The sulphur at first is converted into sulphureous acid gas, and then by the agency of nitrous gas united with oxygen from the atmosphere, or from that liberated from the saltpetre, is gradually converted into sulphuric acid; which is afterwards absorbed by the water that covers the bottom of the leaden vessel. Such is the ordinary mode of producing that article.

The first improvement proposed to be effected by the Patentee, is an instantaneous union of the sulphureous acid gas with the oxygen of the atmosphere, for the purpose of saving the expense of saltpetre, and also the great outlay in providing leaden vessels or chambers, which are requisite in manufacturing sulphuric acid upon a large scale, when the sulphureous acid gas is to be gradually converted into sulphuric acid.

The second improvement proposed is the more perfect condensation of the sulphuric acid by a superior method of absorbing it than that heretofore practised.

The first feature of the improvement, (viz.) that of instantly uniting the sulphureous acid gas with the atmosphere, is effected by drawing them in proper proportions,

by the aid of an air pump, through a heated tube of platina, porcelain, or other material, which is not acted upon chemically, when in a heated state, by the sulphureous acid gas. In this tube or tubes, fine platina wire is to be placed, or platina in a very finely divided state, and to be then heated until raised to a strong yellow heat, and this is best done in a reverberatory furnace.

Sulphureous acid gas being made to pass in this way with a sufficient supply of atmospheric air through such tubes when properly heated, will be instantly converted into sulphuric acid gas, which will be rapidly absorbed as soon as it comes into contact with water.

The sulphureous acid gas is to be generated by the combustion of sulphur or pyrites, or any other metallic sulphuret, in a close oven, having one or more apertures for the admission of atmospheric air, and another aperture leading to or communicating with the tube.

The relative proportions of sulphureous gas and atmospheric air must be regulated by the size and working of the air pump, which must throw out at least eighty-five cubic feet of air for every pound avoirdupois of sulphur consumed.

The improved mode of condensing the sulphuric acid is, by employing a chamber of a circular form, about eight feet in diameter, and thirty feet high, which is proposed to be constructed of silicious stone; but these precise dimensions and materials are not indispensable. This chamber is to be lined throughout with lead, and to be filled nearly to the top with silicious pebbles or any other suitable materials which will present an extended surface, and cannot be acted upon chemically by the acid. Upon the top of the pebbles a sheet of lead is placed, which has been previously perforated with many small holes as a colander.

The top of the chamber is to be closed air tight by a dome, and through a small tube in the dome a quantity of water, or dilated acid is to be poured upon the pebbles. A leaden pump with leaden tubes is to be placed on the side of this chamber, for the purpose of drawing the liquor from the bottom of the chamber, and delivering it through a lead funnel at the aperture in the top of the dome.

This pump is to be kept constantly at work during the operation by means of a steam engine, and the funnel must be always partially filled with liquor, in order to prevent the admission of air into the chamber ; the pump being of such dimensions as will continually raise a sufficient quantity of liquor to keep the pebbles always wet.

A pipe leading from the heated tube above described after passing through water for the purpose of cooling it, terminates in this chamber just above the top of the pebbles ; and another pipe going off from the top of the chamber leads to the air pump. By this contrivance all the air which is passed from the heated tube and charged with sulphuric acid will be made to pass through the bed of pebbles, which having a supply of water or diluted acid continually running down between them, cause the acid to be condensed and absorbed by the water.

When the liquor is considered to have become sufficiently charged with acid, or when it will absorb no more sulphuric acid gas, which may be known by examining the air discharged from the air pump, it is to be drawn off by a pipe or cock in the bottom of the chamber, and treated in the usual way.

The Patentee has not thought it necessary to append drawings to his specification, as it is conceived that the

general construction of the apparatus, which is not confined to any particular form, will be perfectly understood without; but has concluded by saying:—I do not claim a right to any mode by which sulphur or sulphurets may be converted directly into sulphuric acid by the action of heat or otherwise, if such method even has been, or ever shall be discovered, but I claim an exclusive right to any plan by which sulphureous gas and atmospheric air either alone, or mixed with any other gas or gases, shall be either forced or drawn by an air pump, or by any other mechanical means, through an ignited (query heated?) tube or tubes.

I also claim the exclusive right to the use of platina in any finely divided state, for the purpose of assisting the action of heat, in combining sulphureous gas with oxygen in the manufacture of sulphuric acid. I likewise claim an exclusive right to every mode by which chambers used in the manufacture of sulphuric acid, can be charged with silicious pebbles or other substances for the purpose of exposing extensive surfaces, and which surfaces can be either constantly or occasionally moistened by the liquor pumped or drawn from below.—[*Inrolled in the Petty Bag Office, September, 1831.*]

To JOHN DIXON of Wolverhampton, and JAMES VARDY, of the same place, for their having invented certain improvements in cocks for drawing off liquid.—[Sealed 13th December, 1830.]

THIS invention is applicable to that description of cocks which contain a round plug or valve within the interior of the cock, the plug being conical, and fitted to fill up and

stop a corresponding aperture or seat formed in the passage through which the liquor is intended to flow when it is drawn off. The plug is to be pressed down into the aperture of its seat, by means of a screw formed on the upper part of the stem of its spindle, which works in a corresponding hollow screw formed in the head part of the cock.

When the plug is turned so as to screw it down to its seat, the passage of the liquor is stopped, but, on turning it back again, the screw raises the plug, and opens the passage for the flow of the liquor. This is a common construction, and it is upon this kind of cock that the present improvements are founded.

In the ordinary cocks of the description above mentioned, in order that the screw and internal plug or valve may be turned round by means of an external handle or key, the upper end of the spindle of the plug or valve (on the lower part of which the screw is formed) is made to pass through the top part of the cock, and a collar of leather or other flexible material is placed in the seat of the valve, to render the plug tight when shut down. But the liquor is very liable to leak between the stuffing and the seat of the plug, and also at the stem of the spindle, which the present invention is intended to prevent.

The Patentees say, "Our improvement consists in applying the action and force of the external turning handle, by means of which the internal plug or valve and its screw are to be turned round, in order to raise the plug or valve out of its seat, or else to press the same down into the seat, by means of a connection with the lower end of a small stem or spindle, which projects downwards from beneath the plug or valve, and passes through the centre of the aperture of the seat; the external turning handle and its connection with the lower stem of the

plug or valve, being constructed in the manner represented in the drawing. See Plate XI. figs. 7, 8, and 9.

“ By virtue of our improvement, the communication of the necessary motion from the external turning handle to the internal plug or valve, and its screw, being made by means of a stem which descends from the lower side of the plug or valve, and beneath and beyond the seat into which the same is fitted, instead of making the said communication by means of a prolongation of that stem, which ascends from the upper side of the plug or valve, above the seat, no stuffing or collar of leather is required round the stem, whereby we communicate the turning motion to the plug or valve from the outside turning handle; and consequently if the plug or valve fits tightly into its seat, there is no junction of moveable and fixed parts at which the liquor can leak or escape from that part of the passage which is above the seat.

Fig. 7, is an external of the improved cock; fig. 8, is a section of the same, shewing its internal construction, the plug being screwed down, and the passage of the liquor closed. Fig. 9, is a similar section, the plug being raised, and consequently the passage open, as in drawing off the liquor; *a*, is the tube through which the liquor passes from the barrel, or other vessel in which the cock may be fixed, or from a pipe to which it may be attached; *b*, is the orifice or spout through which the liquor is discharged or drawn off; *c*, the conical plug or moveable valve; *d*, is the chamber of the cock, in which the plug acts; *e*, the seat for the conical plug to rest in; *f*, the stem, with the screw on its upper part, having sharp or oblique threads of seven or eight spirals; *g*, the hollow screw or recess into which the stem passes when the plug is raised.

The seat *e, e*, is formed of a distinct piece of metal from the body of the cock, and is attached thereto by a screw cut round it, having a collar of leather to keep it water-tight. The short central tube *h, h*, is formed with a cylindrical socket, and turns freely on the outside of the part *e, e*, by means of the handle *i*. Across the lower part of the stem *f*, there is a key piece, for the purpose of locking the stem to the tube *h*, into two perpendicular grooves, of which the key passes.

When the tube *h*, is turned round by means of the key *i*, the stem goes round with it, and by so doing causes the screw at the top of the stem to draw the plug up, and to open the passage. Turning the handle the reverse way, of course brings the plug down again, and stops the aperture. The rise or obliquity of the threads on the stem, must be such, that by turning the handle about one fourth, the valve will be completely raised, and the passage for the discharge of the liquor opened.

The socket *k*, which turns on the outside of *e*, is attached thereto by studs screwed from the outside, which pass into small grooves, and keep the tube from falling off.—[*Inrolled in the Petty Bag Office, February, 1829.*]

[In the first volume of our present series will be found the specification of Mr. Gossages patent for improvements in corks for drawing off liquors, on comparing which with the present specification, considerable similarity of construction will be perceived. It may therefore be needful to observe, that the former invention has, we understand, now become the property of the present Patentee, and of course any approximation to infringement is of no consequence. ED.]

ON THE FRICTION AND RESISTANCE OF FLUIDS. BY
GEORGE RENNIE, ESQ., V. P. R.S.

[Read before the Royal Society, June, 1831.]
(continued from page 158.)

IN the consideration of this question, I propose to examine, first, the retardations of the surfaces of solids moving in fluids at rest; secondly, the retardations of fluids over solids; and, thirdly, the direct resistance of solids revolving in fluids at rest.

To illustrate the first case, I caused an apparatus to be constructed, of which fig. 10, Plate XI, is a representation; it consists of a cylinder of wood ten inches and three quarters in diameter, and twenty-four inches long, and divided into eight sections of three inches in each, and fixed upon a spindle of iron about four feet in length, and one inch and a quarter thick. The apparatus was accurately turned and polished. Upon the upper part of the spindle, a small cylinder or pulley, six inches in diameter was fixed, and a fine flexible silken cord, communicating with the weight, was wound; the apparatus was then fixed in an iron frame, and the frame let into a groove in two upright posts, driven into the bed of the river Thames.

The object of the frame was to allow the cylinder to slide up and down with the level of the tide, and immerse it more or less according to the experiment required to be tried. The friction of the apparatus, or the time that the weight took to descend in the atmosphere was first noticed; after which it was successively immersed in the water three, six, nine, twelve, fifteen, eighteen, twenty-one, and twenty-four inches, the difference of time showing the retardation according to the annexed Table.

Experiments on the Friction of the Surface of a Cylinder, twenty-four inches long and ten inches three quarters diameter, moving in air and in water.

TABLE I.
On Surfaces in Water.

Depth of immersion of cylinder.	Weight suspended.	Number of revolutions of cylinder falling the whole height of 26 feet.	Time in descending in water.	Velocity of periphery per second in water.	Time in descending in air.	Velocity of periphery per second in air.	Difference between air and water.	Remarks.
inches. 3 6 9 12 15 18 21 24	lbs. 1	Sixteen turns in descending. Periphery moves through 540.32 inches.	seconds. 15.00 18.00 25.00 28.00 32.00 37.00 40.00 55.00	inches. 36.021 30.017 21.612 19.267 16.885 14.603 13.509 9.824	seconds. 10	inches. 54.032	seconds. 5.00 8.00 15.00 18.00 22.00 27.00 30.00 45.00	Resistance increased by surface with slow velocities, but not in the ratio of the surfaces.
3 6 9 12 15 18 21 24	2	Ditto.	9.00 10.00 10.50 10.50 10.50 10.50 11.00 11.00	60.035 54.032 51.459 51.459 51.459 51.459 49.120 49.120	5	108.064	4.00 5.00 5.50 5.50 5.50 6.00 6.00	Resistance scarcely influenced by surface with increased velocities.
On Velocities in Water.								
inches. 24 21 24 24	lbs. 4 8 16 32	Ditto	seconds. 8.0 6.0 4.0 2.5	inches. 67.54 90.053 135.08 216.128	seconds. 2.45 2.00 1.50	inches. 196.49 270.16 360.21	seconds. 5.15 4.00 2.50	Could not be tried.

Conclusions.

1. That the friction or adhesion of water against the surfaces of solids in motion, approximates the ratio of the surfaces with slow velocities; but that an increase of surface does not materially affect it with increased velocities.

2. That with equal surfaces the velocities do not seem to observe any fixed ratio, but approximate to the squares of the resistance.

With increased velocities the index of the power was found to be less than the duplicate ratio.

To exemplify the result of the foregoing conclusions in a different way,—the cylinder was removed, and circular discs of iron, ten inches and three quarters diameter and one-eighth of an inch thick, accurately adjusted to the spindle and polished, were substituted, as fig. 11. The friction of the apparatus was again tried, and immersed in the river Thames, as before.

TABLE II.

Experiments on the Friction in Water of Circular Discs ten inches and three quarters in diameter, and one-eighth of an inch thick, revolving with the planes parallel to the horizon, and six inches apart.

Number of discs.	Weight suspended.	Height fallen of weight.	Time of weight descending in water.	Velocity of periphery per second.	Time descending in air.	Velocity of periphery per second in air.	Difference.
lbs.	lbs.		seconds.	inches.	seconds.	inches	seconds.
1	1	Twenty-five feet, mean circle 16.88 would move through 422 inches.	10.00	42.200	2	211	8.00
	2		5.00	84.400			3.00
	3		3.00	140.660			1.00
	4		3.00	140.660			1.00
	6		3.00	140.660			1.00
2	1	Ditto.	15.00	28.133	2	211	13.00
	2		6.50	64.923			4.50
	3		4.50	93.770			2.50
	4		4.00	105.500			2.00
	6		4.00	105.500			2.00
3	1	Ditto.	17.00	24.823	2	211	15.00
	2		7.00	60.285			5.00
	3		5.50	76.727			3.50
	4		4.00	105.500			2.00
	6		3.00	140.660			1.00
4	1	Ditto.	33.00	12.787	2	211	31.00
	2		17.00	24.823			15.00
	3		8.00	52.750			6.00
	4		6.00	64.923			4.00
	6		4.00	105.500			2.00

Conclusions.

That the friction or adhesion of water is not quite as the surfaces with slow velocities, being in the ratio of one to three instead of one to four, but diminishes rapidly, without observing any ratio in increased velocities.* Hence the resistance of a ship or vessel moving through the water, with an average or higher rate of velocity, forms an inconsiderable portion of the resistance resulting from the displacement of the fluid, and that the brightness observed on the copper of ships after a voyage, may be owing to other causes than the friction of the water simply.

An experiment was made to ascertain the comparative resistance of a pipe revolving in water, and with water running through a pipe; when the resistance was found to be as the surfaces in slow velocities, but to diminish greatly, as before, in high velocities, without observing any fixed ratio.

The above conclusions are in contradiction of those of COULOMB, who did not find that pressure augmented the resistance, but states that the resistance is greater when the immersion is partial.

This apparatus being applicable to fluids generally, advantage was taken of it to ascertain the direct resistance of solids to fluids,† by causing plates and globes to revolve in them, with their planes perpendicular to the plane of the horizon (see fig. 12).

As the resistance of solids in fluids does not form the object of this paper, it will be necessary to introduce many detailed observations on the subject of these experiments at present, connected as they are with another branch of hydrodynamics. But as it is important to show the relation subsisting between the resistances of cohesion and impulse, I have ventured to detail the following experiments:—

* The experiments of the Society for the Improvement of Naval Architecture show a decreased resistance with increased velocities.

† In this case, the number of particles struck will be diminished in the ratio of the radius to the sine of inclination; wherefore the resistance will be diminished in a duplicate ratio of the radius to the sine of inclination. But as the sines of inclination of the two plates are equal, the resistances will be equivalent to the area of one plate (moving perpendicularly to its planes) into the duplicate ratio of the velocity of its motion, and the density of the fluid.

TABLE III.

Experiments on the Rotations of Iron Discs and wooden Balls moving in Air, with their planes perpendicular to the plane of the horizon.

		Time in descending.					
Weight suspended.	Height fallen.	Two circular discs 10 $\frac{1}{2}$ inches diameter. Area 81 inches.	Velocity per second.	Two square fans. Area 81 inches.	Velocity per second.	Two wooden balls 10 $\frac{3}{4}$ inches diameter.	Velocity per second.
		seconds.	feet.	seconds.	feet.	seconds.	feet.
		10.00	6.867	10.00	6.867	23	2.984
		6.00	11.445	7.00	9.810	13	5.282
		4.50	15.261	4.50	15.261	8	8.584
3.00	22.591	3.25	21.180	7	9.810		
2.50	27.469	3.00	22.891	6	11.445		
		The spindle made 15.9 turns in falling 25 feet. Mean circle 51.83 would move 6 to 7 feet.					

Conclusions.

1. That the resistances are as the squares of the velocity.
2. That the comparative resistances between discs and globes are as two to one nearly.

TABLE IV.

Experiments on the Resistance of Iron Discs and Wooden Globes revolving in Water.

Time in descending.							
Weight.	Height fallen.	Two circular discs, 81 inches area.	Velocity per second.	Two square fans, 9 inches square, 81 inches area each.	Velocity per second.	Two wooden balls, 81 inches.	Velocity per second.
lbs. 16	The spindle made 15.9 turns in falling 25 feet. Mean circle 51.83 would move through 824.19 inches or 68.67 feet.	seconds. 63	feet. 1.09	seconds, 53	feet. 1.29	seconds. 15.00	feet. 4.57
20		54	1.27	48	1.43	14.00	4.90
32		43	1.59	40	1.71	10.50	6.59
40		40	1.71	35	1.96	9.50	7.22
64		30	2.28	28	2.45	8.00	8.58
256		14	4.90	15	4.57	5.00	13.73

Conclusions.

1. That the resistances are the square of the velocities.
2. That the mean resistances of circular discs, square plates, and globes in air, are as the numbers 25.180, 22.010, 10.627;

and in water, 1.18, 1.36, 0.755 ; consequently the proportional resistances of air to water, with

Circular discs, is as 1 to 21.3

Plates and fans - - 1 to 16.2

Wooden balls - - - 1 to 2.2

Note.—A portion of the square fans, represented in fig. 12, and equal to one-fourth of the area of each fan, was cut off, when the resistance was found to be the same as with the square fans.

Experiments on the Quantities of Water discharged by Orifices and Tubes of different diameters and lengths, and at different altitudes.

The phenomena incident to spouting fluids are,

First, The inequality observed in the velocity of the particles comprised in every horizontal section parallel to the orifice.

Secondly, The contraction of the fluid vein beyond the orifice, and consequent diminution of discharge as compared with theory.

Thirdly, The inversion and changes in the sections of the fluid vein at different distances from the orifices.

All these phenomena have been noticed and recorded by various writers, and formulæ adapted to the different circumstances of the expenditure have been given. But neither BOSSUT nor DU BUAT (the most accurate of writers), have recorded a continuous and systematic series of experiments upon the comparative expenditure of orifices and tubes under the circumstances of area, altitude, and length.

The apparatus with which these experiments were performed, consisted of a wooden cistern very accurately made, two feet square inside, and four feet four inches in height. The water was kept at a constant altitude by a regulating cock ; and a float having an index attached to it enabled the observer to ascertain the exact height at which the water stood in the cistern above the centre of the orifice.

The orifices were accurately made by DOLLOND in brass plates one sixtieth of an inch in thickness. The plates were accurately adjusted to a hole in the side of the cistern, and closed by a valve

of brass ground to each of the plates. The valve was opened by a lever, and the time noted by chronometers.

The diameters of the tubes, from having been drawn on mandrills, were as accurate as possible; their diameters at the extremities were carefully enlarged, to prevent any wire edges from diminishing their sections; and one extremity of the tube being inserted into a block of hard wood fastened to the cistern, and the other stopped by a valve, the experiments were recorded as before,

Circular Orifice made in a brass plate 1 inch diameter, $\frac{1}{8}$ inch thick.				
Constant height of the surface of the water above the centre of the orifice.	Real time in discharging one cubic foot.	Theoretical time in discharging one cubic foot. $t = \frac{Q}{2A\sqrt{gH}}$.	Ratio of the theoretical to the real discharges.	Vena contracta
feet. 4 3 2 1	seconds. 19.50 21 26 36	seconds. 11.4 13.21 16.1 22.8	1 ; .584 1 ; .628 1 ; .619 1 ; .633	Not accurately measured.
Circular Orifice in a brass plate $\frac{3}{4}$ inch diameter, $\frac{1}{8}$ th inch thick.				
4 3 2 1	33 37 44 63	20.3 23.4 28.7 40.6	1 ; .614 1 ; .632 1 ; .652 1 ; .644	At six tenths of an inch from the orifice, the diameter had contracted to 0.685 of an inch.
Circular Orifice in a brass plate $\frac{1}{2}$ inch diameter, $\frac{1}{8}$ th inch thick.				
4 3 2 1	73 83 104 144	45.7 52.8 64.6 91.4	1 ; .626 1 ; .633 1 ; .621 1 ; .634	At half an inch beyond the orifice, the diameter contracted to 0.37 of an inch.
Circular Orifice in a brass plate $\frac{1}{4}$ inch diameter, $\frac{1}{8}$ th inch thick.				
4 3 2 1	276 320 396 545	182.9 211.3 258.6 365.7	1 ; .663 1 ; .667 1 ; .653 1 ; .671	At a quarter of an inch beyond the orifice, the diameter contracted to one twentieth of an inch less than the orifice.

N.B. Each result shows the mean of four experiments.

Remarks.

The phenomena relative to the form and direction of veins of spouting fluids, and the remarkable inversion of the fluid veins at certain distances from their orifices, have been so fully noticed in “*Experiences sur la Forme et sur la Direction des Veins et des Courans d’Eau ; par George Bidone ; Turin, 1829,*” that it is unnecessary to state further than that they have been completely corroborated in the foregoing experiments.

(To be continued.)

Nobel Inventions.

Fumigating Apparatus.

A philosophical instrument maker in Bristol, named Braham, has lately constructed a simple apparatus, to be employed for the purpose of fumigating hospitals, ships, and the apartments of sick people, and other places impregnated with foul and deleterious vapours ; and for rendering the atmosphere in such places pure and fit for healthy respiration : a subject which cannot be too strongly recommended to the attention of the public in these days of alarm and apprehension, as the most effectual means of preventing the spread of those internal disorders that are now so prevalent under the general title of Cholera, and which in all probability arise from the impure state of the atmosphere in certain localities, more than from any contagious influence.

The apparatus is intended to be carried about the apartment in the hand. It consists of a cylindrical box of tin, about the size of a dark lantern with a handle behind to carry it by, and an opening in front, through which a small spirit-lamp is to be introduced into the

box and reservoir resting on the bottom. In the opening or mouth of the box at top, a small flask or glass retort is placed, containing a small quantity of chemical mixture, which by the heat of the lamp below is made to distil, and consequently to throw off a vapour, the properties of which are calculated to decompose any putrid matter that may be floating in the atmosphere, and also to supply oxygen, which is the great supporter of life.

This apparatus is so compact and simple in its construction, that it may be taken from place to place in the pocket may be introduced into the most confined recesses of an apartment with perfect ease—is in operation in less than a minute after lighting the lamp—gives out in a very short time sufficient gas to purify any moderately sized room, and in cost does not exceed two or three shillings.

Metallic Hone.

A metallic cylinder for sharpening razors, surgical instruments, and pen-knives, invented it is said by T. A. Knight, Esq. President of the Horticultural Society, has lately been manufactured by Mr. Huntly, of Regent's Circus, and is highly spoken of as perfectly effective and much more convenient than an oil stone, answering all the purposes of a hone, and rendering a strop unnecessary.

This instrument is a cylindrical rod of steel, about a quarter of an inch thick, and five inches long. It is rendered perfectly smooth in the first instance, while in its soft state, and is then worked into extremely fine longitudinal lines, by means of fine emery or glass paper, previous to the steel being hardened. It has a silver or plated knob at the top end, by which it is to be held when in use, and when out of use, it is slipped into a cylindrical sheath, as a guard to its surface.

In using this instrument for sharpening the finer kinds of cutlery, such as razors, its surface is to be first moist-

ened with a small quantity of sweet oil and a little rotten stone, or rouge, or indeed any kind of extremely fine grit is to be powdered upon it. The razor being then held perfectly flat upon the surface of the cylinder, is to be worked about in the same way as on a hone; and if the edge of the razor has not been previously rounded by careless setting, the fine lines and the powder upon the steel will very soon bring it to a beautiful smooth cutting edge.

The simplicity and convenience of this instrument is a great recommendation to it, and the cost it appears is as low as from two shillings and sixpence upwards.



A P P E N D I X

To the Report of the Select Committee of the House of Commons, on Patents.

Papers delivered in by John Farey, Esq.

[*British Law of Patents for Inventions.*]

(Continued from page 167.)

J. Williams against J. T. B. Williams, his Wife and another, in Chancery. An application to dissolve an Injunction previously issued by the Vice-Chancellor, to restrain the Defendants from divulging the secret composition of certain Medicines for curing Diseases in the Eye, and from preparing or vending those medicines. Heard 6th August 1817. Injunction dissolved.

The plaintiff had stated that he was the sole owner of the recipes of the medicine, which he had made and sold for many years; that he communicated the secret to his son, the defendant, and had put him in possession of his shop, and stock of medicines, with the intention of taking him into partnership when of age, under certain conditions; but those conditions not being fulfilled, and the

son threatening to expose the secret, the father applied to the court, and obtained the injunction to restrain defendants from proceeding.—The son denied that it was any secret to him, when the communication was made by his father, for that he had been instructed in it in early life, by his mother, who had derived the secret from another, and had communicated it to her husband, the plaintiff.

Lord Chancellor Eldon. “The court was regular in granting the injunction, so far as to restrain the son from selling the articles put into his possession by his father, in the confidence of a treaty for his becoming a partner when of age; for if that did not take place, he was bound to return the articles. But so far as the injunction goes to restrain the son from communicating the secret, upon general principles, I do not think the court ought to struggle to protect this sort of secret in medicine. The court is bound to protect patentees, but that is because they have published their secrets. But whether in the exercise of its jurisdiction, to decree the specific performance of agreements, the court ought to restrain a party from divulging a secret discovery, that he has promised to keep, is a question that would require very great consideration. In this case it is denied that there is any secret, and there appears no ground to support the injunction.”

Canham against Jones, in Chancery. An application to the Vice Chancellor to restrain Defendant from making and selling a Medicine called Velno’s Vegetable Syrup, of which Plaintiff claimed to be the sole Proprietor. Heard before Sir Thomas Plumer, who refused the application, on the ground that the Plaintiff had no exclusive property in the Medicine.

Isaac Swainson had purchased the secret or recipe for preparing the medicine for £.600, thirty years before his death, and he continued all that time the sole proprietor and maker; by his will he bequeathed it to plaintiff, who continued to make and sell the same preparation. Defendant had lately began to sell a medicine, under the same name.

Sir Thomas Plumer, Vice Chancellor. It is an erroneous notion, that there is an exclusive property now subsisting in this medicine, or that Swainson having purchased the secret, and disposed of it by will, had a power to give the plaintiff an exclusive right of sale. If such a claim of monopoly could be obtained without any limitation of time, it would be a much better right than that of a patentee. Nor do the acts of the defendant fall within the cases in which the court has restrained a fraudulent attempt by one man to invade another’s property, by representing himself and his trade or productions, to be that other person’s, in order to appropriate the benefit of a valuable interest in the nature of good will, consisting in the character of the trade or productions established by the individual merit of another.

The King against Metcalf. A scire facias to repeal Metcalf's Patent of 1816, for a Tapered Hair or Head Brush. Tried in the King's Bench before Lord Ellenborough, after Michaelmas Term 1817. Verdict for the Crown.

The specification directed hairs or bristles of the lengths of an inch, and of an inch and a quarter, to be mixed up together, in each of the clusters, which is afterwards to be doubled, and inserted into a hole in the stock of the brush, and fastened therein by a brass wire, whereby the ends of the bristles in each cluster will be of unequal lengths, instead of being all cut down to the same length; as was before done for hair brushes, the same as for clothes brushes, and other brushes.

Lord Ellenborough. "Tapering means gradually converging to a point; according to the specification the bristles would be of unequal length, but there would be no tapering. If that word be used in its general sense, the description is defective; if the term has, by usage of trade, a different meaning, it may be received in its perverted sense; but I cannot hold out any prospect that the difficulty arising from the grammatical consideration can be removed." After some further evidence, which did not remove the difficulty, his lordship advised the jury to find that it was not a tapering, but only an unequal brush. Verdict for the Crown. Motion was made next term for a new trial, but was refused.

Metcalf's hair brushes, with the central bristles of each cluster projecting out beyond the others around the same cluster, have since come into general use; they penetrate the hair much better than those with all the bristles of an equal length.

Hill against Thompson and Forman, in Chancery. An application to dissolve an Injunction previously granted to restrain Defendants from violating Hill's Patent of 1814, for Improvements in the Smelting and Working of Iron. Heard 24th April 1817. Injunction dissolved.

Lord Chancellor Eldon: When an injunction is applied for ex parte, on the ground of violation of a patent right, it is incumbent on the applicant to make affidavit, that at the time of application, he is, in his belief, the original inventor; for although he might honestly have sworn to that effect when he applied for his patent, yet information may have afterwards been communicated, sufficient to convince him, that he had been under a mistaken.

Where there has been an exclusive possession of some duration, under a patent right, the court will interpose its injunction, without putting the party previously to establish the validity of his patent at law. But where the patent is but recent, and it is contended that the patent is not good, the court will not, from its own notions, act upon the presumed validity or invalidity of the patent; but will require the patentee to establish the validity of his patent in a court of law, before it will grant an injunction.

In this case it cannot be said that there has been such a possession, or enjoyment under the patent, as ought to induce the court to continue the injunction, until the validity has been tried at law. The injunction was dissolved, but an account was ordered to be kept of the iron made with slags by defendants according to the method in the specification.—Merivale's Chancery Reports, Vol. III. p. 622.

Hill against Thompson and Forman. An action directed by the Lord Chancellor as above, to try the validity of Hill's Patent of 1814, for Improvements in the Smelting and Working of Iron. Tried in the Common Pleas, at Westminster, after Michaelmas 1817, before Mr. Justice Dallas. Verdict for the Patentee; but Nonsuit was afterwards entered.

The invention was for extracting iron from slags and scoria, which were formerly useless and thrown away as refuse. This was effected by smelting such slags in mixture with certain proportions of limestone, and mine rubbish, or the substance in which iron stones are usually found. Another part of the invention was, the use and application of lime to iron, during its treatment in the furnaces subsequently to the operation of the blast furnace, in order to prevent the quality of coldshort in the iron, that is, brittleness when cold. It was proved that the processes were valuable improvements; but that slags and mine rubbish had been occasionally smelted together before; and also, that lime had been used to prevent cold-short. It was contended, that the mere regulation of principles known before, and practised, would not support the patent; and also, that its title was too loose and general.

Mr. Justice Dallas left it to the jury to say, whether the plaintiff had made out the novelty of the improvements; viz. the conversion of slags into good bar iron, and the prevention of the quality called cold-short by the application of lime. They found for the plaintiff, one shilling damages.—Holt's Reports Nisi Prius, Vol. I. p. 636. Taunton's Reports, Vol. VIII. p. 375. Bayley Moore's Reports, Vol. II. 448.

On the 15th December, 1817, another application was made to the Court of Chancery, in consequence of the above Verdict, to revive the Injunction; but it was deferred by the Lord Chancellor until the result of an application to the Court of Common Pleas, for a new Trial, should be known.

The Lord Chancellor Eldon: After a trial at law, if the patentee is successful, he may apply here to revive the injunction; or else the other party may come before this court, and say, I have displaced all his pretensions, and am entitled to have my costs and expenses of being brought here upon allegation of right, which cannot be supported. But in this case I see enough of difficulty and uncertainty in the specification, and enough of apparent repugnance between the specification and the patent itself, that I

*

cannot take it for granted, that no argument can prevail upon the court of law, to let the question be reconsidered by a new trial; hence it must stand over till the result of the intended application for a new trial is known, an account of the iron made by defendants being taken in the mean time as before.

The words used by the Lord Chancellor on this occasion, respecting what is required in a specification, were cited by Mr. Justice Best on the trial *Brunton v. Hawkes* in 1821.

On the 1st June, 1818, the Court of Common Pleas heard the arguments for a Nonsuit, or a new Trial. A judgment of Nonsuit was entered.

Mr. Justice Dallas delivered the judgment of the court. It is not contended that this is a patent for introducing into use, any one of the articles, slags, lime rubbish, or lime, taken singly, but that it is for combinations and proportions, producing a new effect, by a series of processes unknown before. A slight departure from the specification for the purpose of evasion only, would be a fraud upon the patent; but from the evidence, it appeared that the defendant's mode of working was very materially different from the specification; and our opinion is, that considering the evidence with reference to the peculiar nature of the patent, the infringement is not proved.

“ Every patent must stand either on the ground of an improvement invented, or on the ground of a discovery of something altogether new, and the patent must distinguish itself accordingly. If it is taken out for discovery, when the alleged discovery is merely an addition or improvement, it will be altogether void. The grounds of novelty and discovery, on which this patent must stand, are three. If the discovery claimed were known and used before, the patent is void. I mean to distinguish between the terms novelty and discovery; for it is not enough to have discovered what was unknown to others before, if the discovery be confined to the knowledge of the party having made it; but it must have been communicated more or less to others, or it must have been more or less made use of, to constitute previous discovery, as applied to subjects of this sort.

“ The two cases of *Dollond* and of *Tennant* stand contrasted to illustrate this distinction. In *Dollond's* case the question was, who was the true inventor, within the meaning of the statute? *Hall* had made the discovery before in his closet, but never made it public, and on this ground *Dollond's* patent was confirmed. In *Tennant's* case, a bleacher had used the invention before, but had kept it secret, except from his two partners and two servants; the basis of the improvement had also been previously suggested to *Tennant* by a chemist, in conversation. Under these circumstances, he was not deemed to be the inventor, and was nonsuited.

“ In Arkwright’s case, the idea of drawing out the fibres of cotton between rollers, had been communicated to him by a man, whom he employed in consequence, to make models for him, before the patent ; also the crank and comb, for stripping the cotton off the carding cylinder had been used before. Mr. Justice Buller was of opinion, But although there might have been a general ignorance of these improvements at the time of the patent, the previous knowledge and use by a few, rendered the patent void.”

In the present case there is evidence, stating that the invention is a combination of processes known before separately, but in combination new, and producing a beneficial result ; but this is only negative evidence, which merely proves, that those particular witnesses did not know of the method before ; and, on the other hand, not only knowledge, but extensive use has been proved, of slags, mine rubbish and lime, as used in various ways ; hence there is positive testimony against negative, leaving a result of perfect consistency.

As to the specified combination and proportions of slags and mine rubbish, and lime, considered with a view to utility, the defendants in their working have varied in combination, and departed from the proportions. If the specific combination may be materially departed from, what is there beyond general combination in this patent, which professes to be precise and specific in appointment and application. The use of lime to prevent cold-short is claimed as an improvement, and nothing is said of any previous use, of which this proposed use is averred to be an improvement ; but the specification says, “ I have discovered that the addition of lime will prevent the quality called cold-short,” which, with what follows, is a claim of discovery in its most extensive sense. A book published in 1807 was produced, and negatives the novelty of the alleged discovery, and it was proved to have been practised years ago, as far as the general application of lime, without reference to specific appointment.

If any part of the alleged discovery, being a material part, fail (the discovery in its entirety forming one entire consideration,) the patent is altogether void. In every view of the subject, the claim to novelty fails, not only virtually and technically, as the patent and specification are framed, but in effect and substance, and in the broadest and most enlarged view of the subject.

At the time of the trial, the utility of the alleged discovery being admitted, the fairness of the specification established, and the publicity afforded by the patent, compared with the partial and previous limited use, giving to the public, as it appeared to me, all but the benefit of actual and original discovery, constituted a case so far favourable to the patentee ; but looking to the strictness with which, in point of discovery, patents must be construed, looking to the decisions in cases of the nearest analogy, and to

the peculiar nature of the case, we feel bound to decide against the originality of that which is claimed by the patentee as new. On both grounds, therefore, that no infringement has been proved, and that the invention is not new, we are of opinion that a nonsuit must be entered. An application was afterwards made, to direct a new trial, instead of the nonsuit, but it was refused.

This case was cited by Lord Chief Justice Abbott on the trial of *Brunton v. Hawkes*, in 1821; also by Mr. Justice Best, as a patent which was set aside for claiming too much.

The King against Wheeler. A scire facias to repeal Wheeler's Patent of 1817, for "a New or Improved Method of Drying and Preparing Malt." Tried in the King's Bench after Michaelmas 1818, before Chief Justice Abbott. Verdict for the Crown. The patent cancelled and repealed.

The Judge thought, that "the title of the patent showed, that it was obtained for a different thing than that stated in the specification; the patent being for preparing malt, which must mean making it from barley, whereas the specification appeared to be for drying malt already made. It was also defective, in not stating the purposes to which the article when prepared, was to be applied, (viz. colouring beer and porter,) nor in describing the process with sufficient precision. These questions arising upon written instruments, and being therefore properly a question of law, the Judge directed a verdict for the Crown.

Motion being made the next term for a new trial, Chief Justice Abbott gave the opinion of the court, viz. for himself, Mr. Justice Bayley and Mr. Justice Holroyd, in February 1819.

"The language in which the supposed invention is described in a patent, is that of the patentee himself; he represents to the Crown that he has invented the thing, and that he is the first and sole inventor; the Crown, yielding to his representation, and being willing to encourage inventions, that may be for the public good, grants him the sole privilege for a time, under specified conditions. If the patentee has not invented the thing of which he represented himself to be the inventor, the consideration of the grant fails, and it becomes void, even if he has invented some other thing, which, upon a due representation thereof, would have entitled him to a grant. The word 'manufactures,' in the statute 21 James I. has been generally understood to denote either a thing made, which is useful for its own sake and vendible as such; as a medicine, a stove, a telescope, &c. or to mean an engine or instrument, or some part of an engine or instrument, to be employed either in the making of some previously known article, or in some useful purpose, as a stocking-frame, or a steam-engine for raising water from mines: or it may perhaps extend also to a new process to be carried on by known implements, or elements, acting upon known substances, and ultimately producing some

other known substance, but producing it in a cheaper or more expeditious manner, or of a better and more useful kind. But no merely philosophical or abstract principle can answer to the word manufactures. Something of a corporeal and substantive nature, that can be made by man, from the matters subjected to his art and skill; or at least some new mode of employing practically his art and skill, is requisite to satisfy that word. He who applies for a patent, may represent himself to be the inventor of some new engine, or instrument, or of a new method of accomplishing the object which is to be accomplished by that new engine or instrument. Thus Mr. Watt represented himself to be the inventor of a new method of lessening the consumption of steam in fire-engines; and by his specification, described certain parts to be used in the construction of fire-engines. Or supposing a new process to be the lawful subject of a patent, he may represent himself to be the inventor of a new process, in which case the word 'method,' may be properly used, as synonymous with process. The language of the patent may be explained and reduced to certainty by the specification: but the patent must not represent him to be the inventor of one thing, and the specification show him to be the inventor of another; because perhaps, if he had represented himself the inventor of that other, it might have been well known that the thing was of no use, or was in common use, and he might not have obtained the grant."

The patentee, Wheeler, represented himself to be the inventor "of a New or Improved Method of Drying and Preparing Malt." Malt was an article of common use, and prepared by a process, of which drying was one of the last stages; we must suppose, by reading the patent, that he had invented some new process of preparing, or drying, this old article; but looking at the specification, we find he claims a method by a second and additional process, and a high degree of heat giving to malt, when previously prepared, some qualities which it did not possess before, or only in a slight degree, viz. solubility in water, and colouring that liquor, which last is the object in view. "We think the invention mentioned in this specification, entirely different from that mentioned in the patent." If he had represented himself to be the inventor of a method of preparing malt, for the purpose of colouring beer and porter, every one reading the specification, would understand that the malt so prepared, was not intended for the common purpose of brewing beer, but was intended for colouring the liquor, and to be used in addition to common malt. Neither has he described any certain or precise process, which, admitting that there may be a patent for a process only, ought unquestionably to be done. Verdict confirmed. The patent ordered to be repealed.

Wood against Cockerell. An application to the Lord Chancellor to restrain the Defendants from violating Wood's Patent of

1815, for Spinning Machines; heard 24th August, 1819. The application was refused; the patent right being doubtful, it was left to the chance of being established by a verdict of a jury, if the Patentee chose to proceed at law.

Bloxam and Another, assignees of H. and S. Fourdrinier, bankrupts, against Elliot. An action for infringement of Gamble's patents of 1801 and 1803, for a Machine for making Paper, the terms of which were extended by Act 47 Geo. III. Tried in the King's Bench in 1819. Verdict for the Patentee. See further trials, *Bloxam v. Elsee*, in 1825 and 1827.

Brunton against Hawkes and Co. An Issue, directed by the Lord Chancellor, to try the validity of Brunton's Patent for 1813, for Improvements in the construction of Ships Anchors and Windlasses, and Chain Cables or Moorings. Tried in the King's Bench, after Easter Term, 25th May 1820, before Lord Chief Justice Abbott. Verdict for the Patentee; but a new trial was afterwards granted; on the judgment of the court, that the patent was void; consequently no further proceedings took place.

The infringement was upon the chain cable, of which the great utility and security to shipping was fully proved. The first chain cables were made by Captain Brown, with twisted links, a wrought-iron stay being fixed across the middle of the opening of each link, to keep them from collapsing. The links of Brunton's chain cables were not twisted, but were made in the strongest form, and the stays across the links were made of cast-iron, with broad ends adapted to the sides of the link, and embracing them. This kind of link had come into general use for chain cables, in place of Brown's, who himself had also adopted Brunton's links.

It was contended, that Brunton's link was not a new invention; also, that the anchor was not a new invention: and that the specification was defective in not giving any dimensions for the stay across the link, for it was only represented in the drawing, which is not an instrument in writing, as directed by the patent. The Court overruled the objection, for "if a drawing or figure will enable a workman of competent skill to construct the improvement, it is as good as any written description." The jury found, that the specification was sufficient, that the chain cable, and the anchor, were both new and useful, and that the defendants had infringed the plaintiff's chain cable. Damages one shilling. The novelty of the windlass was not disputed.

(To be continued.)

New Patents Sealed 1831

To Robert William Sievier, of Southampton Row, in the parish of Saint George, Bloomsbury, in the county of Middlesex, gentleman, for his having invented or discovered certain improvements in the making or manufacturing of cables, ropes, whale fishing and other lines, lathe and rigger bands, bags, and purses, part of which said improved articles are applicable to other useful purposes. — Sealed 1st December, 6 months for Inrolment.

To Cornelius March Payne, of Stratford, in the parish of West Ham, in the county of Essex, silk printer, for his having invented or discovered certain improvements in printing silk, cotton, and other goods or fabrics. 3d December.—6 months.

To Claude Marie Savoye, of Oxford Street, in the county of Middlesex, merchant, for a new invention of which he is in possession, consisting of an improvement or improvements in mills or machines for grinding or reducing grain and other substances.—15th December.—6 months.

To Abraham Adolph Moser, of Canterbury Row, Kennington Road, in the county of Surry, engineer, in consequence of a communication made to him by a certain foreigner residing abroad, for an invention of which he is in possession, of improvements in certain descriptions of fire-arms.—15th December.—6 months.

To Thomas Alcock, of the parish of Claines, in the county of Worcester, lace manufacturer, for his having invented or found out certain improvements in machinery already in use for the manufacture of bobbin-net lace.—15th December.—6 months.

To Isaac Strombom, of Old Broad-street, in the city of London, merchant, for his having invented a medicinal composition or embrocation for the cure, relief, or prevention of external and internal complaints; which composition or embrocation may alone, or with certain alterations, be beneficially used as an internal medicine.—17th December.—6 months.

To Daniel Ledsam, manufacturer, and William Jones, screw manufacturer, both of Birmingham, in the county of Warwick, for their having invented certain improvements in machinery for making pins, rivets, woodscrews, and nails.—22d December.—6 months.

To Henry Gore, of Manchester, machine-maker, for his having invented an improvement in the machine commonly called by spinners “Throstle Frames,” and spinning frames; which machines operate by spindles and flyers and bobbin, for spinning or twisting yarn or threads. 22d December.—6 months.

To Pierrepont Greaves, of Chorley, in the county of Lancaster, gentleman, for his having invented or found out a method or methods of making ornamental or fancy cotton yarns and threads applicable to the making, sewing, or embroidering of cotton and other fabrics.—22d December.—6 months.

To John Christopher Tobias Kreeft, of Old Bond Street, in the city of London, merchant, in consequence of a communication made to him by Stephen Von Keesz and Moritz Von Ischoffen, foreigners, residing abroad, for an invention of which he is in possession, of an improved apparatus for shaping plates of metal, and for manufacturing various articles therefrom.—22d December.—6 months.

To Samuel Hall, of Basford, in the county of Nottingham, cotton manufacturer, for his having invented an im-

proved piston and valve for steam, gas, and other engines; also an improved method of lubricating the pistons, piston rods, and valves or cocks of such engines, and of condensing the steam and supplying water to the boilers of such steam engines as are wrought by a vacuum produced by condensation.—22d December.—6 months.

To Benedict Nott, Esq. of Liverpool, in consequence of a communication made to him by a certain foreigner, residing abroad, for an invention of which he is in possession, of certain improvements in the construction of a furnace or furnaces for generating heat, and in the apparatus for the application of heat to various useful purposes, being further improvements upon a patent obtained by the said Benedict Nott; dated the 4th day of November, 1830.—22d December.—6 month.

To Malcom Muir, of Hutchinson Town, Glasgow, Scotland, engineer, for his having invented or discovered certain improvements in machinery or apparatus for preparing boards for flooring and other purposes.—22d December.—6 months.

To Robert Walker Wingfield, of Birmingham, in the county of Warwick, brass founder, for his having invented certain improvements in the construction of bedsteads; one or more of which said improvements is or are likewise applicable to other articles.—22d December. 6 months.

Chancery Lane, London.

NEWTON AND BERRY,
Office for Patents.

Meteorological Journal, 1831.

1831.	Thermo.		Barometer.		Rain in in- ches.	1831.	Thermo.		Barometer.		Rain in in- ches.
	Hig.	Low	Hig.	Low.			Hig.	Low	Hig.	Low.	
Oct.						Nov.					
26	57	46	29,54	29,48	,025	11	53	43	30,20	30,15	,225
27	57	46	29,78	29,66	,225	12	53	45	30,19	30,14	
28	57	43	30,09	30,00	,2	13	53	43	30,08	30,00	
29	58	40	30,22	30,18		14	43	24	30,02	29,85	
30	53	33	30,17	30,14		15	41	27	29,46	29,37	
31	49	43	30,13	30,80		16	35	27	29,35	29,26	
Nov.						17	41	22	29,58	29,51	
1	57	42	29,99	29,84		18	41	23	29,65	29,60	
2	52	45	29,72	29,66	,2	19	41	24	29,52	29,46	,15
3	52	39	29,52	29,42		20	41	27	29,80	29,61	
4	49	28	29,74	29,66		21	57	31	29,74	29,58	,5
5	47	31	29,51	29,36		22	58	50	29,91	29,76	,2
6	53	29	29,43	29,36	,1	23	58	50	29,93	29,91	,05
7	51	39	29,51	29,39	,075	24	54	43	29,97	29,96	
8	49	38	29,69	29,56		25	54	42	29,86	29,83	
9	47	27	30,26	30,04							
10	45	22	30,32	30,16							

1831.	Thermo		Barometer.		Rain in in- ches.	1831.	Thermo		Barometer.		Rain in in- ches.
	Hig.	Low	Hig.	Low.			Hig.	Low	Hig.	Low.	
Nov.						Dec.					
26	54	28	30,10	29,91		11	55	39	29,47	29,35	,025
27	41	28	30,32	30,10		12	54	40	29,33	29,16	,1
28	37	22	30,38	Stat.		13	53	42	29,48	29,32	,2
29	41	27	30,44	30,42		14	48	33	29,60	29,55	,025
30	46	25	30,93	30,09		15	46	33	29,73	29,64	
Dec.						16	46	29	29,79	29,76	,05
1	48	33	30,09	30,02	,1	17	45	30	29,65	29,59	,225
2	48	40	29,99	29,96		18	46	38	29,39	29,30	,3
4	48	39	30,05	30,02		19	44	31	29,60	29,49	
5	51	39	29,96	29,86		20	43	29	29,63	29,58	
6	50	40	29,80	29,56		21	45	32	29,76	29,56	,15
6	51	39	29,42	29,38		22	46	26	29,75	29,53	
7	53	43	29,99	29,90	,05	23	30	26	29,71	29,55	,025
8	55	43	29,22	29,15	,175	24	37	24	29,94	29,81	
9	55	46	29,20	29,10	,425	25	31	21	32,24	30,07	
10	54	43	29,43	29,32	,3						

CELESTIAL PHENOMENA, FOR JANUARY, 1832.

H. M. S.		D ³	H. M. S.	
1 0 0	0 Clock before the ☉ 3 min. 35 sec.	16 6 0	0 ☽ in conj. with ξ in Gemini	
1 0 0	0 ☿ Stationary	17 3 53	0 Eclip. oppon. or ☉ full m.	
2 15 12	0 Ecliptic conj. or ● new m.	17 20 0	0 ☾ in conj. with δ in Cancer	
3 20 0	0 ☽ in conj. with ♄ lon. 26 in Sag. ☽ lat. 1. 30 N. ♄ lat. 1. 12. diff. of lat. 18	18 17 0	0 ♃ in conj. with B in Oph	
4 9 0	0 ♀ in conj. with ♄ in Libra	19 5 0	0 ☾ in conj. with α in Leo	
5 0 0	0 Clock before the ☉ 5 min. 27 sec.	20 0 0	0 Clock before the ☉ 11 min. 11 sec.	
5 3 0	0 ☽ in conj. with ♄ in Caps.	20 10 0	0 ☾ in conj. with ♄ long. 13, in Leo. ☾ lat. 2 46 N. ♄ lat. 2. 1 N. diff. of lat. 44.	
5 6 0	0 ☽ in conj. with ♄ long. 25. in Caps. ☽ lat. 2 N. ♄ lat. 39 S. diff. of lat. 41.	20 11 29	0 ☉ enters Aquarius	
6 3 0	0 ☽ in conj. with ♃ long. 24. in Cap. ☽ lat. 1. 1. S. ♃ lat. 54 S. diff. of lat. 7.	21 0 0	0 ☿ Stationary near 1 ξ in Sagit.	
8 0 0	0 ♀ in conj. with ν in Scorpio.	22 19 0	0 ♀ in conj. with ρ in Orph.	
10 0 0	0 Clock before the ☉ 7 min. 37 sec.	24 5 3	0 ☾ in ☐ last quarter	
10 12 50	0 ☽ in ☐ or first quarter	25 18 0	0 ☾ in conj. with γ in Libra.	
11 16 0	0 ☽ in conj. with 2 ξ in Ceti	26 5 0	0 ☾ in conj. with λ in Libra.	
12 19 0	0 ☽ in conj. with f in Taurus	26 22 0	0 ☾ in conj. with φ in Orph.	
13 1 0	0 ♄ in conj. with d in Sag.	28 23 0	0 ☾ in conj. with 1 μ in Sag.	
13 16 0	0 ☽ in conj. with 1 δ in Taurus	29 3 0	9 ♄ in conj. with π in Sag	
15 0 0	0 Clock before the ☉ 9 min. 33 sec.	30 0 0	0 Clock before the ☉ 13 min. 33 sec	
		30 4 0	0 ☾ in conj. with γ long. 15 in Sag. ☾ lat. 2. 27. N. γ lat. 1. 14. diff. of lat. 1. 13	

The waxing moon ☽.—the waning moon ☾

J. LEWTHWAITE
Rotherhithe.

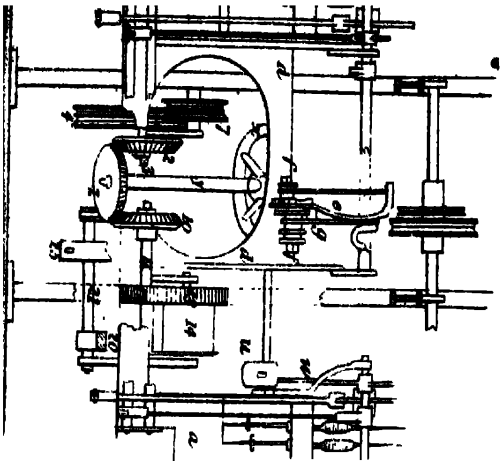

Fig. 1

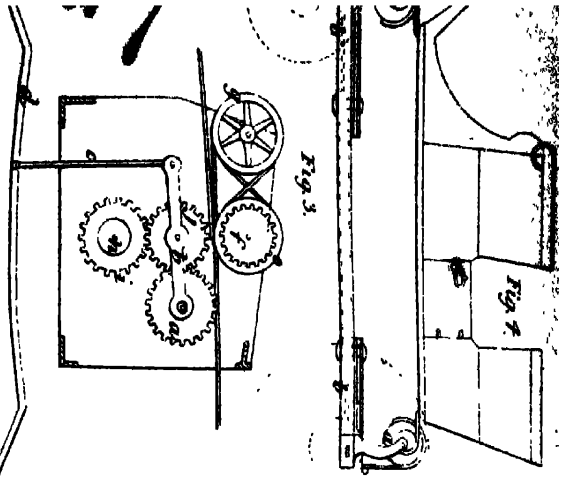

Fig. 3

Fig. 4

Fig. 6

Fig. 5

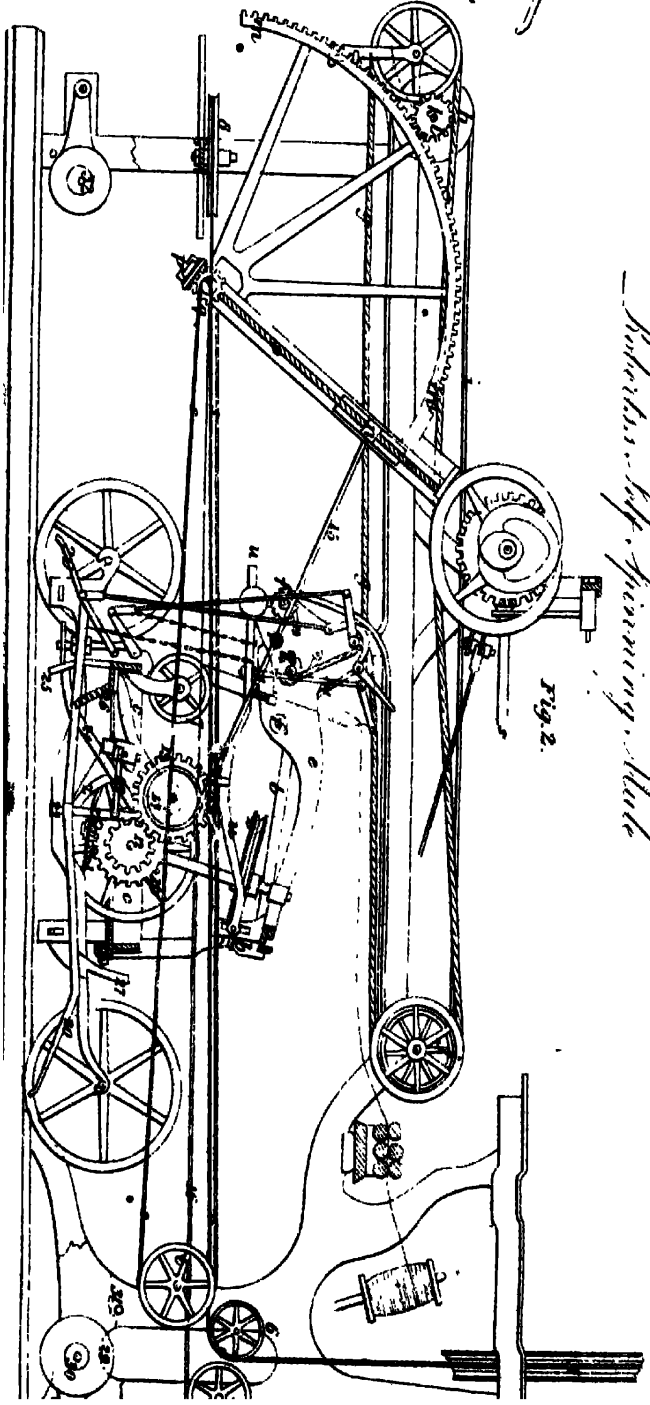
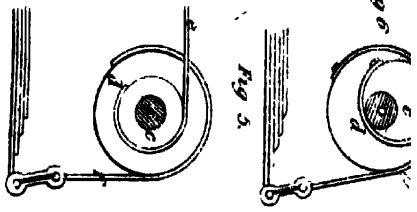

Fig. 2

Bobbin-Top Spinning-Frame

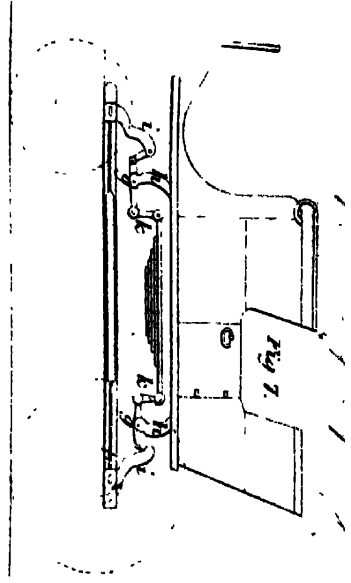

Fig. 7

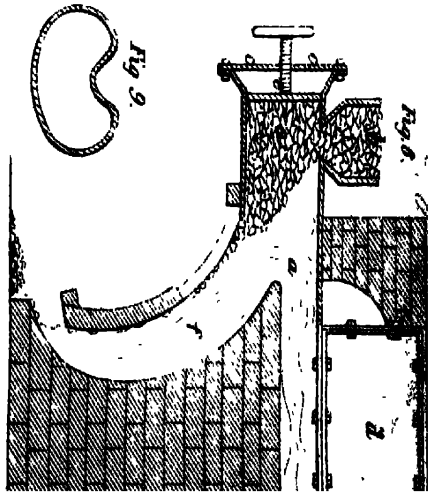
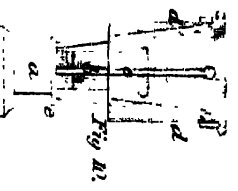
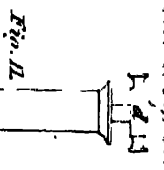
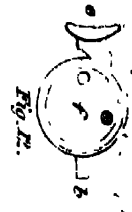

Fig. 8

Fig. 9

Figures 1, 2, 3, 4, 5, 6, 7, 8, 9, 10, 11, 12, 13, 14, 15, 16, 17, 18, 19, 20, 21, 22, 23, 24, 25, 26, 27, 28, 29, 30, 31, 32, 33, 34, 35, 36, 37, 38, 39, 40, 41, 42, 43, 44, 45, 46, 47, 48, 49, 50, 51, 52, 53, 54, 55, 56, 57, 58, 59, 60, 61, 62, 63, 64, 65, 66, 67, 68, 69, 70, 71, 72, 73, 74, 75, 76, 77, 78, 79, 80, 81, 82, 83, 84, 85, 86, 87, 88, 89, 90, 91, 92, 93, 94, 95, 96, 97, 98, 99, 100



Figures 1-10

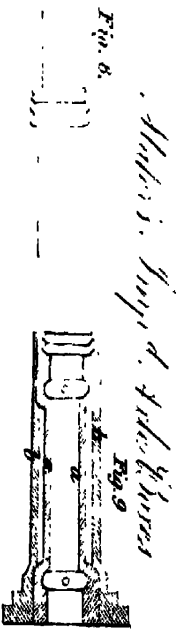
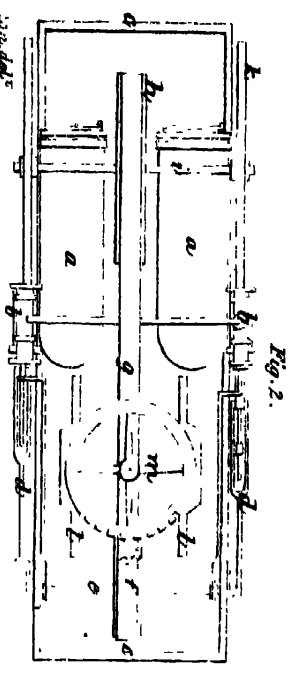
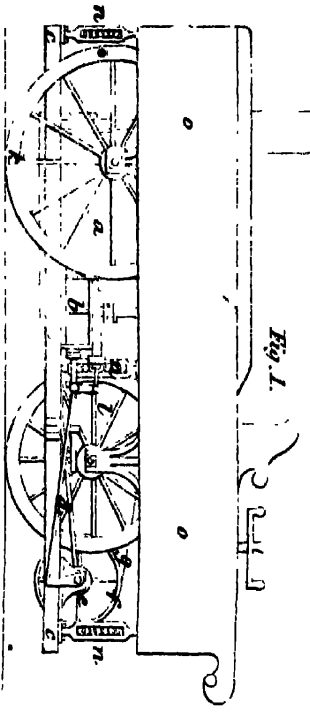

Figures 11-13

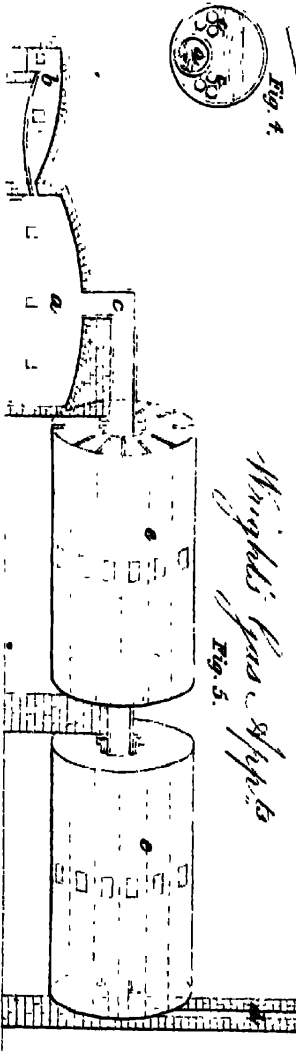
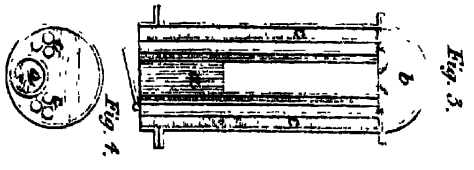
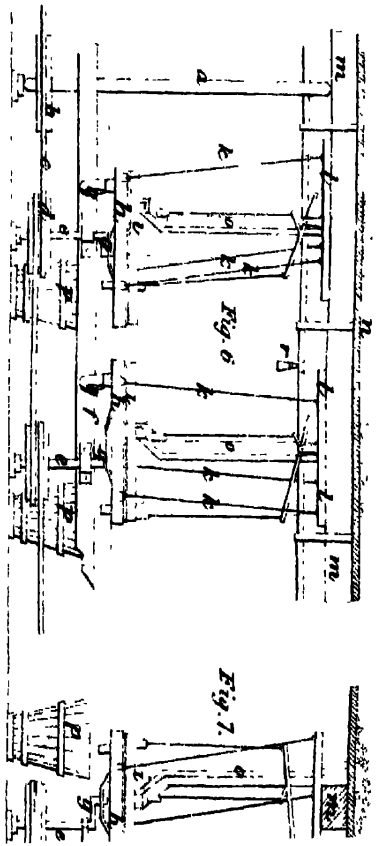

Figures 14-16

Figures 17-19

Figures 20-22

THE
London
JOURNAL OF ARTS AND SCIENCES.

No. XLVII.

[SECOND SERIES.]

—*—
Recent Patents.

To RICHARD ROBERTS, of Manchester, in the county of Lancaster, civil engineer, for his having invented or found out a certain improvement, or certain improvements in the mechanism employed to render self-acting, the machines known by the names of mule, billy, jenny, jack-frame or stretching frame, and all other machines of that class, whether the said machines be made to rove, slub, or spin cotton, or other fibrous substances.
[Sealed 1st July, 1830.]

THE particular object of this invention is to communicate to the spindles varying speeds, which shall enable them at all times to take up or wind on the yarn with uniform tension, although the cop may differ materially in its diameter at the several parts of the operation.

The machinery being driven by the power of steam, must possess in itself that regulating property which shall

effect the different adjustments usually performed by the hands of a skilful spinner, and this it appears the Patentee has accomplished in the present invention with greater success than any of his predecessors who have attempted the like object. The following is the Patentee's description of the invention:—

“ The nature of my said invention consists of an improvement or improvements in the mechanism employed to render self-acting the machines commonly known by the names of mule, billy, jenny, jack-frame, stretching frame, and all other machines of that class, whether used to rove, slub, or spin cotton, or other fibrous substances, the particular object of which improvement or improvements is to effect in a more complete manner than has hitherto been done by self-acting machines of the kinds above mentioned, the regular winding on of the yarn, or roving, upon the spindles, by regulating their rotary motions according to the gradually varying form and increasing diameter of the cop.”

In Plate XII. several parts of a mule are represented, which are not described, such as the carriage wheels, the carriage rail, the going-in scroll and cord, the fallers, and part of the framing. These parts, as well as some of those which are described, are well known to persons conversant with mules and other machines of the same class, and are merely introduced, in order to explain better the nature of the improvement.

“ In figs. 1 and 2, *a, a*, is a mule carriage in two parts, one on each side of the headstock, the parts being firmly united by *b, b*, a connecting bar of iron, and *c, c*, an iron frame; to this is bolted in front a frame of iron *d*, which at its upper part is supported by *e*, a spur piece, bolted to the bar *b*, and to the frame *d*. On studs in the spur piece are *f, f*, two ratchet tension barrels, to one of

these is fastened *g*, a cord, which after passing over a notch in the spur piece *e*, is wound round and fastened to *h*, a drum or barrel; this has also attached to and coiled round it *i*, another cord, which after passing over *j*, a guide pulley, and a notch in the spur piece, is attached to the other ratchet barrel. A shaft *k*, on which is keyed the drum *h*, has a pinion *l*, working into *m*, the toothed quadrant, which receives an alternating motion on its centre, through an arc of about 90° whilst the carriage runs out and in, that is to say, at every stretch.

“ In a groove in the inner arm of the quadrant is *n*, a sliding nut, moved by *o*, a double threaded leading screw, on the lower end of which is keyed *p*, a mitre wheel, gearing with *q*, another mitre wheel, the central stud of which is opposite to the centre of the quadrant. Attached to the back of mitre wheel *q*, is *r*, a pulley, which is turned at intervals by *s*, an endless strap, passing round it, and *t*, a sliding pulley. A weighted lever *u*, called the governor lever, is moveable on a stud in the back part of the carriage frame, and forms the upper jaw of a pair of pincers, the lower jaw being *v*, a stud in the carriage end.

“ The lever *u*, when not intended to press upon the stud *v*, is carried by an adjustable nut on the lower end of *w*, a rod connected with the arm of the counter faller; and having free play through a hole in a side projection from the arm of the lever. When in winding on, the tension of the yarn brings the faller wires to nearly the same level, the dropping of the arm of the counter faller allows the lever *u*, to descend till it pinches the endless strap *s*, against the stud, and drags it along as the carriage runs in, until the rise of the counter faller arm again raises the lever, and liberates the strap. The spindles are banded in the ordinary way, and the drums are driven by a band,

which after taking both the grooves in x , the driving pulley, is spliced, instead of passing from the carriage to the twist pulley as in common mules. The pulley x , is keyed on y , an inclined shaft, the upper end of which turns in a swivel collar, and the lower end or foot in an arm of a bell crank.

“ During the process of twisting and backing off, the shaft y , receives motion through 1, a mitre wheel, which is keyed near its lower extremity, and is driven by 2, another mitre wheel, fixed on 3, a shaft, on which is also keyed 4, a double grooved driving pulley, receiving motion by an endless band from 5, the twist pulley above. This pulley band passes under a carrier pulley, and over a double grooved carrier pulley, under the driving pulley 4, again over pulley 7, and under pulley 4, round 8, a sliding carrier pulley, under 9, a carrier pulley, and thence to the twist pulley.

“ The mitre wheel 1, comes occasionally into gear with 10, another mitre wheel, keyed on 11, a shaft, upon which is also keyed 12, a spur wheel, which gears into 13, another spur wheel, firmly connected to 14, a drum or barrel, which is called the winding-on barrel.

“ The diameters of wheels 12 and 13, should be made to give as nearly as possible the proper amount of rotation to the spindles, according to their diameters and those of the warves, the final adjustment being made in the diameter of the barrel 14, the whole being adapted to give so much motion to the spindles, as will cause them to wind on the whole stretch at the first run in.

“ There is a cord 15, one end of which is tied to the sliding nut n , in the arm of the quadrant m , and the other made fast to the barrel 14, after having made several coils round it; and 16, is an opposing cord, also coiled round and fastened to the barrel 14, and after passing under 17, a

carrier pulley, and over 18, another carrier pulley, it sustains 19, a counterpoise, which causes the barrel 14, to take up the cord 15, as the carriage recedes from the rollers.

“ A lever 20, inclined downwards at both ends, is mounted at its middle upon 21, a tumbler shaft, carrying 22, a fixed vertical arm, which is connected by 23, a link, with the side arm of the bell crank ; 24, is a stopping bar, moveable on a stud in the vertical arm of the tumbler shaft, its lower end passing through and abutting by a shoulder against the upper side of a mortice hole in 25, a stopping piece, which is bolted to the frame *c* ; the stopping bar is held against the upper side of the slot by 26, a spiral spring ; 27, is a latch, on a stud in a projection from the frame *c*, which is pressed by 28, a spring, in the direction of a catch on one side of the lever 20 ; 29, is a radial weight, moveable on a stud in the framing, and carrying on a stud near its centre 30, a friction roller, under which the inner inclined arm of the lever 20, passes, and raises the weight a little, just before the carriage completes its run inwards ; 31, a stud in the framing, which by stopping the latch 27, in its motion inwards, disengages the lever 20, at the instant the carriage has completed its run ; which allows the weight 29, to depress the inner arm, and so to throw into gear the mitre wheels 1, and 2, preparatory to the re-commencement of twisting ; 32, is another radial weight, similar to the weight 29, having a friction roller, under which the outer arm of lever 20, comes to raise it, as the carriage reaches its outward limit.

“ When the process of backing off is completed, the mechanism for putting up, or running the carriage in is put into gear, and simultaneously with it ; and by the same or any other convenient means, the stopping bar 24, is depressed, and the weight 32, depressing the lever 20,

shifts the mitre wheel 1, from the wheel 2, into gear with the wheel 10.

“ The diagram fig. 3, is intended to shew the arrangement of the connecting wheels, the winding on barrel, and the crooked lever, when the spindles are driven by bands from a roller, instead of drums, which, as far as the present improvement or improvements in the mule, billy, jenny, jack frame, or stretching frame, are concerned, is almost the only difference in the several machines enumerated; they all being machines of the same class, that is, in which is performed at intervals the winding on of the stretches of yarn or rovings, though used for different purposes, and distinguished by different names.

“ A spur wheel *a*, is keyed on the coupling shaft which connects the spindle band rollers on each side of the headstock; *b*, is a radial arm, centred on the same coupling shaft and connected by *c*, a link, with *d*, the crooked lever, which is acted upon by the radial weights and catches, as described before; *e*, a double grooved pulley, keyed on the same shaft with *f*, a spur wheel; *g*, a double grooved carrier pulley, round which and the pulley *e*, the twist pulley band is passed twice, as before explained; *h*, the winding on drum, keyed on the same shaft as *i*, a spur wheel; *j*, a spur wheel, carried by the radial arm *b*, and gearing into wheel *f*, whilst the twist is being given, and into wheel *i*, during the winding on.

“ In the adaptation of the present improvements to the mule, billy, jenny, jack frame, or stretching frame, according to the diameter of the cop to be formed, or the length of stretch made in the several machines, it may be requisite to vary the length of the grooved arm of the quadrant. Whilst the carriage is running in, it turns by the band *g*, fig. 2, the drum *h*, its shaft *k*, and the pinion *l*, which works into the quadrant *m*. When the quadrant

begins to move, its grooved arm stands about 12° beyond the vertical position from the rollers, and during its action, it turns on its centre inwards, through an arc of about 90°

“ At the commencement of a set of cops, the stud in the nut n , to which the cord 15, is attached, is set opposite or nearly so, to the centre of the quadrant, in which position it suffers no change of place by the motion of the quadrant. As the carriage recedes from the point of attachment of cord 15, it causes the rotation of the winding on drum 14, round which the cord is coiled, and the drum, through the train of wheels 13, 12, 10, and 1, that of the pulley x , which by the spindle drums gives motion to the spindles, (see fig. 1.)

“ The rotation of the spindles during the first run in of the carriage, just suffices to wind on the stretch of yarn upon the bare spindles. As the diameter of the cop increases by each succeeding layer, fewer revolutions will be requisite to effect the winding on of the constant length, and therefore the whole quantity of motion imparted to the spindles during a run in, must undergo progressive diminution, so long as the diameter of the cop is increasing, which goes on until the bottom is formed. This decrease of motion in the spindles is obtained by lessening the quantity of cord to be uncoiled from the winding on barrel; an effect which results from the advance of the nut n , along the arm of the quadrant, the amount of the effect being exactly commensurate with this advance, as is apparent when the grooved arm of the quadrant, at the end of the run in, nearly coincides with the line of traction of the cord 15.

“ The motion which slides the nut along the quadrant arm is produced in this way. During the process of backing off, the spiral coils of yarn are unwound from the ends of the spindles, and the faller is depressed when the counter

faller by its weight rises, and takes up the uncoiled or slack yarn, and thus the faller wires keep up the tension as the yarn is uncoiling. Whilst the carriage is running in, the spindles, in winding on the stretch of yarn, take up by degrees the coil yarn also, and as this is effected, the faller wires are brought to nearly the same level. At the first run in, this approach of the faller wires takes place only as the carriage comes up to the rollers. The power of winding on increasing as the diameter of the cop enlarges in the subsequent stretches, the coil yarn gets taken up before the carriage has run home; and when this occurs, the descent of the counter faller allows the governor lever u , to fall, and to pinch the endless strap s , against the stud v . With the motion of the carriage the strap is dragged along, and turns the leading screw o , which slides the nut n , towards the circumference of the quadrant.

“ The strap continues to be dragged until the retardation of the taking up from the diminished velocity of the spindles thus produced, permits the counter faller again to rise, and relieve the strap from the pinch of the lever. In this way the nut n , is made to advance upon the quadrant arm, in proportion as the expanding diameter of the cop accelerates the action of winding on, and a correspondent abatement in the whole number of revolutions of the spindles is the result. As soon as the cop has attained its full diameter, that is, when the bottom is formed, the winding on power then remaining uniform, the governor lever is no longer made to act upon the strap, and, consequently, the nut n , travels no farther from the centre of the quadrant during the completion of the cop.

Besides the adjustment of the whole amount of winding on motion, each stretch is adjusted to the growing diameter of the cop, which is effected by causing the point of attach-

ment of the drag cord 15, to advance progressively upon the rim of the barrel 14. The grooved arm of the quadrant by carrying the point of attachment of the cord 15, after the first stretch through an arc of about 90° at each run in, causes the cord to be uncoiled from the barrel 14, by a ratio increasing as the carriage recedes from the quadrant, and this variable rotation of the barrel is increased by the successive shifts of the nut *n*, from the centre of the quadrant, thus adapting the rotation of the spindles to the winding on powers of the cop, through its various diameters from the base to the summit of the cone.

Having now described my improved mechanism for adapting the rotation of the spindles to the regular taking up of the yarn or roving, as the form and diameter of the cop changes throughout the operation of winding on, I do hereby declare, that my invention consists in the method or means to be employed for that purpose hereinbefore described. The mechanism thus employed by me affects the rotation of the spindles in two ways; first, rotatory motion is given to a drum or barrel, which turns the spindles whilst the carriage is running in, by uncoiling from it a portion of a cord, strap, or chain, attached to the drum, and having its other extremity fastened at some point in a radial arm which describes an arc, whilst the winding on drum is receding from the point of attachment of the cord in a right line. This compound motion adjusts the rotation of the spindles to the varying power of taking up by the conical cop as the yarn or roving is being coiled on its different diameters, during the winding on of each stretch.

Secondly, during the progress of the formation of a cop, the situation of the point of attachment of the uncoiled end of the cord, strap, or chain, on the radial arm is changed progressively, as the increasing bulk of the cop demands

fewer revolutions of the spindles to take up the stretch, and, consequently, there is a shorter length of the cord to be uncoiled from the barrel. And I declare that I claim as my invention, the mechanism or combination of mechanical movements requisite for producing the above stated effects, which I have herein fully set forth, however the arrangement may vary from that now described; and I further declare, that I do not claim as of my invention such parts of the mule and other machines of that class herein described, as act in aid of, or in concert with my present improvements, which have heretofore been in common use in similar machines; nor do I include in my present claim for invention, the action of the fallers, which has been described and claimed by me in the specification of a former patent, granted me by his late Majesty King George the Fourth, and dated at Westminster, 29th March 1825; (see Vol. XIII. Page 6, of the First Series of our Journal).—[*Inrolled in the Inrolment Office, 1831.*]

To AUGUSTUS GRAHAM, a citizen of the United States of North America, but now residing in West Street, Finsbury, in the city of London, gentleman, in consequence of a communication made to him by a certain foreigner residing abroad, for certain improvements in the application of springs to carriages.—[Sealed 17th December, 1830.]

THE object of this invention is to furnish the means of suspending coach bodies and other vehicles, in such a manner that the vibratory motions to which they are subject when travelling, by the ordinary modes of hanging, may be in a great measure diminished, if not totally prevented. The springs of the carriage may be of the usual kind, that is, of hardened steel, or elastic wood,

and they may be either attached to the perch or to the body of the carriage, or to both; but between the end of the spring and its place of attachment, a pulley and axle is introduced, with straps or chains for connecting them together, the intention of which is, that the pulley at the point of suspension may turn upon its axis, and thereby take up that portion of the vibratory action to which the body of the carriage is subjected when passing over inequalities on the road.

These pullies are proposed to be made with pivots or axles, turning in holes at the extremities of the brackets, or crane-necked supports affixed to the body or perch of the carriage, and they are to be formed by either concentric or excentric rollers of different diameters; or levers of different lengths may be affixed to the rotary axles instead of the pullies, one end of the suspension straps or chain being attached to the end of such levers, and the other to the body of the vehicle, or to the end of the spring.

In order to exhibit examples of this contrivance, the Patentee has appended drawings to his specification, shewing the forms and modes of connecting the parts. Plate XII. fig. 4, is a side view of the body and perch of a phæton, with the connections and pullies; *a, a*, are the crane-necked supports fixed to the perch *b, b*, the axles turning in eyes or holes near the extremities of the crane-necks. Where there are springs on both sides of the carriage, as there usually are, at the back part, there are two double pullies *c, d*, of different diameters, affixed to the axle, the constructions of which are shewn in the detached figures 5 and 6; but where only one spring is used, as is sometimes the case in front of the carriage, then the larger pulley is proposed to be placed in the middle, and two of the smaller at the ends.

To the peripheries of these pulleys *c*, and *d*, the suspension straps are attached as in fig. 5, which represent a pair of concentric pulleys, and fig. 6, a pair of excentric pulleys. The strap *e*, passes from the under part of the carriage to the periphery of the smaller pulley *c*, and the strap *f*, from the periphery of the larger pulley *d*, to the end of the spring.

In cases where it may be preferred to employ levers instead of pulleys, as shewn in the side view of a phæton, fig. 9, then the levers *g*, *g*, are to have arms of dissimilar lengths, and to be suspended at the fulcrum points upon pivots or axles turning in the brackets *h*, *h*, affixed to the under side of the carriage body; the ends of the shorter arms of the levers being connected to the crane-necked supports *i*, *i*, which are affixed to the perch of the carriage, and the end of the longer arms of the levers to the springs *k*. When only one spring is employed, which is frequently the case in front, then the longer arm of the lever must be placed in the middle of the axle, and the two shorter arms one near each end.

In the conclusion of the specification, the Patentee says—"Having thus shewn and described several methods of carrying the said invention into effect, I hereby declare that it is not my intention to limit or confine myself to the employment of those methods only, but to avail myself of every other mode or method by which the said invention of applying springs to carriages by the introduction of axles may be effected, either with excentric or concentric wheels, or pulleys of different diameters affixed upon them, or with arms or levers mounted upon the said axles of different lengths.

"And I also claim the application of springs, either to the bodies, or perches, or frame work of carriages, and either in the methods herein shewn and described, or in

any other mode where the said axles with wheels or pulleys of different diameters mounted upon them, or with levers of different lengths are used to apply springs to carriages."—[Inrolled in the Inrolment Office, June, 1831.]

To DAVID NAPIER, of Warren Street, Fitzroy Square, engineer, and JAMES NAPIER, and WILLIAM NAPIER, of Glasgow, engineers, for their invention of certain improvements in machinery for propelling locomotive carriages.—[Sealed 4th March, 1831.]

THESE improvements consist, in the first place, in communicating the power of the engines to the wheels of the carriage, by means of belts, straps, or bands of leather, or any other flexible material, which work upon pulleys or drums; the one fixed upon a shaft connected to the engine; the other upon the wheels or axle; the second is in the peculiar construction of the boiler.

Plate XIII. fig. 1, is an elevation of the locomotive carriage; fig. 2, a horizontal view of the same, the similar letters referring to corresponding parts in both figures; *a, a*, are two steam boilers; *b, b*, the working cylinders of two engines; *c, c*, the framing which carries the boilers and the engines; *d, d*, are the connecting rods, and *e*, the crank shaft of the engines. Upon this crank shaft is fixed the pulley or drum *f*, from which the strap *g*, communicates the power of the engine to the pulley or drum *h*, fixed in the middle of the axle *i*, of the hind wheels *k, k*.

The axle of the fore wheels *l, l*, has a horizontal or locking movement, by its attachments to a horizontal plate or wheel *m*.

The boilers and engines are firmly connected together by the framing *c, c*, which is suspended by helical springs

n, n, n, from the upper frame work *o, o*, which bears upon the axles of the running wheels, and, consequently, have no connection with the carriage but through the springs and the driving belts or bands.

By this arrangement, the engine and all its appendages are relieved from the jolts and vibrations to which the wheels are subjected when running on ordinary roads, and which has been found so extremely detrimental to machinery. The contrivance therefore admits of locomotive engines running on ordinary roads. and may also be adapted to suit railways. The Patentees, however, profess to lay no claim to the particular arrangement of machinery above described, "but merely as above, to the application of the belt, strap or band, made of leather, or any other suitable substance, with either cylindrical or conical rollers or drums, to communicate the power of the engine or engines to the wheels of carriages."

As respects the peculiar construction of boiler proposed, fig. 3, is a horizontal section, shewing the interior with the furnace and flues, and fig. 4, is a vertical section of the same; *a*, is the furnace, from whence one large flue proceeds to the opposite end *b*, which is hemispherically formed, and from *b*, the flues return through the several small tubes *c, c, c*, fig. 4, to the front part of the boiler, where they discharge the vapour and smoke into the chimney. The flues are all surrounded by the water, and there is space left at top for the steam, which passes from thence to the working cylinders of the engine.

The Patentees say, that they "lay no claim to the number, size, or form of the tubes or flues that compose the boiler; they may consist of more or fewer, be larger or smaller, or of whatever form that may suit best the plans of the engineer; and instead of one main or large tube or flue *a*, it may consist of two or more; also, the

furnace or furnaces may be either wholly or partially within the main flue or flues, or may be wholly without them, and connected to them; as also, the form of the reservoir or chamber may be varied at pleasure; but what we claim on this head is a reservoir or chamber, into which the flue or flues coming from the furnace or furnaces terminate, and from which reservoir or chamber another set or number of flues commence, and return through the boiler, as stated above, into the chimney or outlet at the furnace end of the boiler."—[*Inrolled in the Inrolment Office, September, 1831.*]

To RICHARD WITTY, of the township of Hanley, in the county of Stafford, engineer, for his having invented or found out certain improvements in apparatus for making and supplying coal gas for useful purposes.—[Sealed 10th June, 1828.]

THERE are two features claimed under this patent; the one is a mode of generating gas from coal, and at the same time burning the gas for the purpose of heating a boiler, while the coke is preserved and drawn off; and the other is a peculiar form of retort for generating gas for the ordinary purposes of illumination.

Plate XII. fig. 8, shews a section of the apparatus to be employed; *a*, is a furnace, which the Patentee considers as a retort; *b*, is a hopper above, to be filled with coals, which are let down from the hopper on to the bottom plate of the retort. Some ignited coke is first to be placed upon the coal through the retort mouth *c*, which is then to be closed as retorts usually are when in operation. The top of the coal being thus ignited, gas will be given off, and that gas immediately becoming inflamed, acts in the flues against the bottom and sides of the boiler

d, where steam is by the heat generated for working an engine, or for any ordinary purpose.

As the coal becomes exhausted of its gas, it is to be gradually pushed forward by screwing up the plate *e*, at the retort mouth, and in so doing, the coke is pushed down the passage *f*, and delivered at the bottom.

Fig. 9, is a transverse section of a retort for generating gas for illumination. The retort is to be made of cast iron as usual, but the particular improvement is what the Patentee calls its V form, or indentation on the top, which not only causes it to last longer in operation, but also to give out more gas than those of the ordinary construction.

The Patentee's claims of novelty are his mode of carbonizing the coal and delivering the coke, and also the peculiar form of retort described, which together constitute the whole of the improvements in apparatus for making and supplying coal gas for useful purposes.—[*Inrolled in the Petty Bag Office, December, 1828.*]

To RICHARD WITTY, of Basford, in the parish of Wolstanton, in the county of Stafford, engineer, for his having invented or found out certain improvements in apparatus for propelling carriages, boats, or vessels, and for other purposes, by the power of steam. [Sealed 13th December, 1830].

THE Patentee commences his specification in these words; “instead of applying the power of steam to produce only angular and circular motion for the purpose of propelling carriages, boats, and vessels, in the usual manner, I construct and arrange the working parts of my said steam engine apparatus so as to divide the expansive or elastic force of steam betwixt the piston and the end of

the cylinder, in such a manner as to convert the re-action of the steam upon the end of my cylinder into a projectile force; which force is employed in propelling the carriage, boat, or vessel, forward, or in a rectilinear direction, while, at the same time, the force of the piston itself is employed in producing angular or circular motion, being connected to a wheel or wheels, which are thus turned round, and proceed or move in the line of direction in which the carriage, or boat, or vessel moves."

What the Patentee means by this, we are at a loss to understand. Our notion is, that the ordinary construction of the steam engine is intended to effect precisely the same object, viz. to divide the expansive or elastic force of the steam betwixt the piston and the end of the cylinder, in such a manner as to convert the re-action of the steam from the end of the cylinder upon the piston into a projectile force or first mover, to drive any other kind of machinery; and as to that force being in a rectilinear direction, we are not aware of the possibility of producing a projectile force in any other than a rectilinear direction; it can only become angular or circular by the force impinging upon some resisting medium, which causes it to deviate. For instance, the rectilinear force of the piston being made to impinge in angular directions upon a crank, moves that crank round the axis of its shaft, and thus is derived the rotary motion. If the Patentee fancies he has invented this, or has been the first to discover this as a principle, he is mistaken; if he does not mean this, we are at a loss to discover what he does mean, or in what his invention consists.

The specification goes on to describe a carriage with three single stroke steam engines, the cylinders of which are placed horizontally, and the three piston rods are severally connected to a three-throw crank, with the run-

ning wheels fixed upon the ends of the shaft. The middle cylinder may be made as a double stroke engine, for the convenience of backing the carriage; and the same contrivance is also applicable to propelling boats; but the Patentee disclaims any novelty in the construction of the machinery, and concludes his specification with these words; "I claim the combination of the two principles, viz. angular and rectilinear motion as before produced from the power of steam in giving motion to carriages, either on railways or common roads, and in giving motion to boats or vessels, and for other purposes."—[*Inrolled in the Petty Bag Office, January, 1831.*]

To ROBERT WORNUM, of *Wigmore Street, Cavendish Square, in the county of Middlesex, piano-forte maker, for certain improvements on upright piano-fortes.*—[Sealed 24th July, 1828.]

THE Patentee commences the description of his invention by stating, "The novelty is applied to the lever and the key, and effects a check to the hammer when in action." What may be the object of this is left to be inferred, as the specification throws no further light upon the matter, excepting that it is said "the lever is longer than usual, as may be seen in the drawing," which drawing is an outline sketch of what we presume to be part of the mechanism usually called the action of a piano-forte; but there are no letters of reference by which the several parts alluded to might be pointed out.

It appears that an upright pin is set in the hinder part of the key, and a small block is fixed upon the top of this pin, which, when the key is struck, stops against a piece (we presume called the lever) that stands over it. This is said to simplify the construction of an upright piano-forte, and that is all the account we can give of it. [Inrolled in the Inrolment Office, January, 1829.]

To MARIE ELIZABETH ANTOINETTE PERTUIS, late of Rue de Bal, in the city of Paris, and kingdom of France, spinster, in consequence of a communication made to her by a native of France, for an invention of the fabrication of a coal, fitted for refining and purifying sugar, and other matters.—[Sealed 23d December, 1830.]

THE clarification of sugar is usually effected by the employment of carbonaceous materials after the dross or molasses has been extracted, and which is applied to bleach and render the saccharine crystallization white, or colourless. The material proposed by the Patentee to be employed for this purpose, is a mixture of animal or vegetable matter, with earth or clay and alkaline salts.

Of the animal or vegetable materials to be used for this purpose, bones, from which the gelatine has been extracted in making glue, is proposed, or coal tar discharged from gas works, or molasses, or blood, or peat, or bark after it has been exhausted by tanners, or any other material which has a carbonaceous base, and can be procured at a small expense; of the earthy matters, clay, river sand, or mud, may be employed; and of the salts, muriate of soda, common salt, or muriatic acid, or lime, or other alkaline salts which are not costly, will answer the purpose.

These materials, in various proportions according to their qualities, are to be mixed together, and after having been dried, are to be calcined and then granulated to about the fineness of gunpowder; they are afterward to be washed repeatedly in water, for the purpose of getting rid of the salt taste; and when that has been completely effected, the compound is fit to be employed in purifying sugar in the same way that carbonaceous matters have been heretofore used for the same purpose.—[Inrolled in the Petty Bag Office, February, 1831.]

To JAMES WRIGHT, of Newcastle-upon-Tyne, soap maker, for his new-invented improvements in condensing the gas or gases produced by the decomposition of muriate of soda and certain other substances, which improvements may also be applied to other purposes.—[Sealed 28th April, 1829.]

THE Patentee states, that he builds a circular wall of from four to six feet in height, and of what diameter may be deemed necessary for the extent of the operation ; the wall, forming a chamber, is to be covered over with a roof or dome, having one outlet in the centre, for the purpose of conducting the gas away, which will be best understood by reference to the drawing shewn in Plate XIII. at fig. 5.

The bottom part of the circular chamber *a*, is to be lined to the height of about a foot from the ground with lead or other material which will keep it water-tight ; and around the chamber are to be erected any convenient number of decomposing and drying furnaces, one of which is represented at *b*. The flues from each of these furnaces lead into the central chamber *a*, so that the gas from all the furnaces is there delivered as a general receptacle.

Into this chamber lime water is to be continually thrown by means of a force-pump and hose, the end of the hose having a perforated cap, which distributes the water horizontally in a shower. This water having previously been impregnated with lime, attracts a great portion of the gas from the furnace, and then settling in the bottom of the chamber, forms a reservoir of lime-water, which greedily absorbs a large portion of the gas when it is in the chamber, and also assists in cooling that portion of the gas which has not become condensed, and thereby renders it in a proper state for the subsequent operations.

The uncondensed gas passes off from the chamber by the central flue *c*, and proceeds in a horizontal direction toward the chimney *d*; but in its progress passes through the cylindrical vessel *e*, which is lined with lead. Within this cylinder there are many shelves standing radially and parallel to the axis, as shewn by dots; and between each shelf there is an external opening with a cover, for the purpose of introducing a quantity of slacked lime.

The cylinder is made to revolve by any convenient rotary appendage, the ends of the pipe constituting the axle on which it turns, and by this means the lime is continually raised to the highest part of the cylinder, and then let fall; and by thus continually pouring down, keeps the atmosphere within constantly loaded with lime, in a very minute state of division; through this the gas passing in its progress to the chimney, becomes so completely absorbed, that the vapour which ultimately escapes into the chimney will not discolour a test paper if held in it.

Two cylindrical vessels *e*, may be employed, as shewn in the figure, which will render the success of the operation more certain, and allow an opportunity of changing the lime in one, while the other is at work.

The Patentee claims as his invention, “the application of lime for absorbing the muriatic gas, and this particular mode of application;” and adds, that “the resulting muriate of soda, is an article of considerable importance in the arts, and may be sold at such a price as will nearly cover the expense of the operation.”

The other objects to which the Patentee says his invention is applicable are, first, absorbing the sulphuretted hydrogen gas drawn off from the reverberatory furnaces in which the soap-maker calcines his neutral salts, technically called black ash: a process so extremely offensive

that it is obliged usually to be carried on in remote places, at considerable distances from towns.

In this adaptation of the invention, retorts may be substituted in place of the furnaces in the drawing; and the same results will be produced, enabling the soap-maker to carry on all his operations in the same premises, although they may be situate in the centre of a town or city.

Secondly, the invention is applicable to the more perfect purification of coal gas. The gases, as they come from the retorts, being passed through the chamber and cylinders, where the lime is in so complete a state of division, and presenting such a constant succession of surfaces, that the whole of the sulphuretted hydrogen is absorbed, leaving the carburetted hydrogen in a state of great purity. To obviate the chance of any escape of gas at the pivots of the cylinders, it is only necessary to keep the balance of the gas-meter equal to or greater than its own weight.

Thirdly, the application of the cylinders alone to the manufacture of chlorate of lime, is productive of great advantages. The Patentee says, he decomposes the muriate of soda in one set: of retorts, and drives off, by means of heat alone, the oxygen from the black oxide of manganese in another set: the pipes from each terminating in a horizontal main or general receiving pipe, on both ends of which are to be placed any number of revolving cylinders charged with fine lime, which by this method becomes completely saturated. The residuum is in one set of retorts, sulphate of soda without any admixture of sulphate of manganese; and in the other, manganese deprived of a part of its oxygen, which, upon being exposed for a time, in thin strata, to a circulation of atmospheric

air, speedily recovers the oxygen it had lost, and becomes fit for future operations. The manganese, of course, must be used in excess, by which a great saving will be effected, and the chlorate of lime produced of a much superior quality.—[*Inrolled in the Inrolment Office, October, 1829.*]

To WILLIAM WEDD TUXFORD, of Boston, in the county of Lincoln, miller, for his having invented a machine or apparatus for cleansing or purifying wheat, grain, or other substances.—[Sealed 6th July, 1830.]

THIS invention consists in the adaptation or combination of a series of sieves, in connection with other machinery, to be driven by the power of water or steam, for cleansing grain by sifting; the apparatus resembling in some degree the corning machinery of a gunpowder mill.

Plate XIII. fig. 6, is a front view of a portion of the apparatus, to which two sieves only are appended, for the purpose of illustrating the contrivance; fig. 7, is a side view of the same; *a*, is the main shaft, placed perpendicularly, and supposed to be driven by water or steam; *b*, is a drum, fixed upon the main shaft, from which a band *c*, passes to a small rigger *d*, fixed on the spindle or crank shaft *e*, and a similar band proceeds from thence to the rigger of the second spindle, and so on. This spindle turns in a step below, and in a bearing or loop above, secured to the framing *f, f*.

The crank *g*, at the top of the spindle, works in a cross frame fixed to the bottom of the box *h*, in which the sieve *i*, is placed; and the sieve is suspended by three swing rods *k, k, k*, from a ring or hoop *l*, affixed to the top beam *m*. The corn or other grain intended to be cleansed, is placed on the floor *n*, above the machinery;

and it is passed through an aperture down the pipe or trunk *o*, into the sieve, the quantity, of course, being regulated by a slider in the aperture.

Rotary motion being communicated to the drum *b*, all the spindles *e, e*, are driven round, which causes their cranks to give to the boxes *h, h*, and sieves *i, i*, rapid vibratory movements, as shewn by dots, which shifts the grain in the sieve *i*, carrying the dirt and small seeds through the wire gauze into the box *h*, beneath; and the sieve being upon a slight inclination, the grain will be progressively conducted to the lower side, and by that means made to descend through a small hopper into the receiver *p*; while the dirt and seeds collected in the box *h*, will fall into the small bag or sleeve *q*; and may be removed from thence, when necessary, by untying the end of the bag. It will be found that the lighter parts, such as the husks and shells, will rise to the top of the grain while sifting; these must be removed by hand; and when the process is required to be stopped, a handle and shaft *r*, is to be turned, which shuts off the supply of grain from the trunk *o*; and if any one of the sieves are required to be put out of action, that is done by removing the driving band from the rigger or pulley *d*, upon its crank shaft *e*.

In conclusion the Patentee says, I would have it understood, that although I have here described parts of my apparatus or machinery which separately are well known and in use, yet I lay no claim to them separately; but I claim the combination of such parts in the manner described, and apply them when so combined, to the purpose of cleansing or purifying wheat, grain, or other substances; and I further claim the acting on sieves suspended as above described, by means of cranks, in the manner above described, and for the purposes above named.—[*Inrolled in the Inrolment Office, January, 1831.*]

To JOHN SLATER, of Birmingham, in the county of Warwick, manufacturer of coach springs and axle-trees, for his having invented certain improvements in axle-trees and the boxes for carriage wheels.—[Sealed 15th December, 1828.]

THE subject of this Patent appears to be confined to the manner of making the box of a carriage wheel, without any regard to its form. The Patentee states, that the ends of the axle-trees are to be made in the way shewn in Plate XIII. at fig. 8, with a large hole or recess in its end, represented by dots, for the reception of oil, and with small holes leading therefrom, in order to allow of the oil flowing over the bearing part of the axle; but he afterwards says, his axles may be made with or without this oil chamber.

The box of the wheel is to be made as shewn in the section at fig. 9, with recesses to contain the oil, but to this particular form he does not confine himself; *a, a*, is a shell of brass, made to the shape of the axle; *b, b*, is a wrought iron cylindrical case, fixed on the outside of *a*. The iron case *b*, is to be fitted to the external shape of the shell *a*, and when hot, it is to be passed over the shell *a*, and shrunk on to it.

The Patentee says, he does not confine himself to making the shell *a*, of brass, as it may be of any other suitable material; but he claims to be the first inventor of attaching an external case of wrought iron to the box of the wheel, by shrinking it on in the way described; which contrivance may be employed in making the boxes of carriage wheels, whatever may be the peculiar form of them, or of the axles intended to work within them. [*Inrolled in the Inrolment Office, June, 1829.*]

To MARMADUKE ROBINSON, of Great George Street, Westminster, navy agent, in consequence of a communication made to him by a certain person residing abroad, for certain improvements in the process of making and purifying sugars.—[Sealed 5th August, 1830.]

THE cane juice which is to be operated upon, being placed in the vessel in which it is to be boiled, finings are to be mixed with the juice, composed, as the Patentee describes it, of a saturation of alum and lime, in the proportion of about two pounds of finings diluted in pure water, to every hundred gallons of juice; which is to be properly stirred up and mixed with the juice.

“ I next proceed (says the Patentee) to render the juice perfectly neutral, so that there be no excess of either acid or alkali, and the method which I prefer for so neutralizing the juice, and for ascertaining when the neutralization is perfect, is as follows:—I mix with the juice lime dissolved in water, and made into what is commonly called milk of lime, which should be made sufficiently thin, to allow the undissolved particles of lime to subside, and give to the water the appearance of milk, using such milk of lime in the first instance in small portions, and adding thereto from time to time, until I have ascertained, in the manner and by the experiments hereinafter mentioned, that sufficient milk of lime has been applied.

“ After each throwing in or addition of the milk of lime, I carefully examine the liquor with any one of the test papers, commonly used for detecting the presence of acids in liquids, and when this paper has ceased to change colour, I examine the liquor with one of the test papers commonly employed for detecting the presence of alkali

in liquids, in order to ascertain whether too much milk of lime has been applied, in which event I add more of the juice until the last mentioned test paper has ceased to change its colour.

“ In this manner I proceed throwing in more milk of lime, or of the juice, according to the indications of the respective test papers, until I have ascertained that no change is perceptible on either, and that therefore the juice is perfectly neutral

“ The liquor being thus rendered neutral, I next proceed to heat it in the vessel, until it has nearly reached the boiling point, taking care however that it does not actually boil; and this I prefer to do in wooden vessels, by means of steam.

“ The wooden vessel may be made of any convenient shape and size, and within it is to be fitted a copper worm or pipe, of a size suited to the dimensions of the vessel. The steam should be made to circulate through this worm, which must be fitted with cocks, to regulate the letting on of the steam, and the escape of the waste steam and condensation. This worm pipe is to be so connected with the steam generator, as to admit of the steam passing freely through it.

“ After having thus heated the liquor, I discontinue the steam, and then mix a further quantity of the finings, diluted as before, in the proportion of about three pounds of finings to every hundred gallons of juice; and after stirring it up, I examine the liquor in a tumbler or other glass vessel, to observe the rapidity with which the impurities precipitate; and I go on adding further portions of the said finings, until I find that the addition of such finings does not increase the rapidity of the precipitation; from which circumstance I ascertain that a sufficient quantity of the finings has been applied.

“ My improvement, so far as regards the application of the finings, consists in the finings being applied to the cane juice itself ; but I do declare, that although I have found such application of the finings highly useful in carrying the said improvement into effect, still that such application is not indispensably necessary, and that the said improvements may be carried into effect (although less advantageously) without such application of the finings. I then allow the liquor to remain at rest. The impurities, which by the ordinary mode of operating, remain suspended in the body of the liquor (and are got rid of by skimming during the boiling of the liquor), will then be precipitated to the bottom ; and those which, in the ordinary method of operating, float on the surface of the liquor, previously to the boiling, will float in the same manner when the operation is conducted according to the present specification. I allow the liquor to stand till the body of it has become cleared from both these impurities ; I then draw it off into the evaporators, so as to allow the pure liquor to pass off, separated from the impurities which have precipitated, as well as from those which float at the top.

“ This may be conveniently effected by the means of cocks placed at a convenient height from the bottom of the vessel ; the remainder of the liquor is afterwards separately drawn off, together with the impurities, into another vessel, in which I mix with it a small quantity of pure warm water, and allow the mixture to settle ; the impurities will then separate themselves from the mixture. As soon as the body of this liquor has become clear, I draw off the clear part from the impurities, as on the former occasion, by means of a cock placed at a convenient distance from the bottom of the last-mentioned

vessel, and add it to the liquor already in the evaporators.

“ I claim the benefit of these letters patent, for the above described method of precipitating and separating that portion of the impurities, which, in the ordinary method of operating, remains suspended in the body of the liquor, and is only got rid of by skimming during the process of boiling ; and I declare, that although I prefer to all other methods of heating for the present purpose, the method of heating in wooden vessels as before described, yet the precipitation above described may also be effected when other methods of heating are used, provided the cane juice be in other respects treated according to this specification, and provided also, the vessel in which it is intended that the precipitation should take place be cold.

“ I next proceed to boil the liquor into syrup or sugar, and I prefer boiling it in vacuo by the application of steam ; and in that case I prefer employing what is commonly called high pressure steam, that is to say, steam generated under a pressure of not less than twenty pounds to the square inch ; steam of a pressure from twenty to forty pounds to the square inch will fully answer the purpose, but in general cases I would recommend a pressure of about thirty-five pounds.

“ I also declare that this application of high pressure steam to the boiling in vacuo, will be found highly beneficial in the boiling of any saccharine solution, for the purpose of manufacturing refined or other sugars. I apply such steam by means of a vacuum pan formed like Howard's, or any other known vacuum pan, except that there is no contrivance for applying steam to the exterior of the vacuum pan, and except so far as the construction of the vacuum pan is altered by the construction herein-

after described; one or more branch pipes are carried from the steam main, which proceeds from the boiler of a high pressure steam engine; these branch pipes enter the vacuum pan at different heights, and each branch pipe terminates in a worm or coil of pipes, circulating horizontally round the interior of the vacuum pan.

“ The worm or coil of pipes, when there are more than one, lie one over the other, but are not in actual contact; it will be convenient to make them all finally terminate and unite within the vacuum pan in one single pipe, by which the condensed water or waste steam is to be discharged. This discharge pipe passes through the bottom of the vacuum pan, and at a convenient distance from it with a common high pressure steam regulating cock, the use of which is well understood.

“ The juice or other saccharine solution having been poured into the vacuum pan, and the vacuum having been produced, as in Howard's or any other known method, the high pressure steam is let into the branch pipes, and will circulate through them, and through the worms or coils of pipes in which they terminate, and the condensed water or waste steam will be discharged by the discharge pipe.

“ I declare that I claim the benefit of these letters patent generally, for the above method of applying the high pressure steam to the boiling in vacuo, both for boiling cane juice and for boiling any saccharine solution for the purpose of manufacturing refined or other sugars.

“ With respect to the liquor which has been treated in the method described, in so much of this specification as precedes the directions for boiling by high pressure steam in vacuo, I declare that if from any circumstance it should be found inconvenient to boil in vacuo, the liquor may be boiled in wooden tubes made of any con-

venient size ; and by the application of steam in this last case, the tubs should be fitted in the interior with a copper worm, of a size suited to the dimensions of the tubs, through which worm (having the necessary cocks to let on the steam, and allow the condensed water or waste steam to escape), the steam is allowed to circulate.

“ The tubs should be placed one higher than the other, in such manner as to admit of the liquor being drawn from one to the other successively, and so into the concentrator, by means of cocks or valves ; the sugar when boiled, may be drawn from the concentrator by a cock, valve, or any other convenient means.

“ The advantages of boiling in wooden tubs are very considerable, but I declare that I do not claim the benefit of the present letters patent for the boiling in such wooden tubs, and that I greatly prefer the method of boiling in vacuo, and by high pressure steam, as herein-before mentioned ; I treat the sugar when boiled by either of the above mentioned methods, in the way now usually practised by sugar boilers, and which it is unnecessary to particularize, and I put such sugar either into hogsheads or moulds, as may be found most convenient.

“ And, lastly, I do hereby declare that I claim the benefit of the said letters patent, so granted to me as aforesaid, in respect only, first, of the above-described method of purifying cane juice, by precipitating that part of the impurities which, according to the ordinary method, is only got rid of by skimming, during the boiling of the liquor ; secondly, of the application of finings to the cane juice ; and thirdly, of the application of high pressure steam, to the boiling in vacuo of cane juice, or of the saccharine solutions, for the purpose of manufacturing refined or other sugars. And with re-

spect to all the matters and parts of the operation hereinbefore described (and which are already well known); I hereby disclaim all title to originality, and I declare that so far as I have described the same, I have done so only for the better explanation of the said improvement."—[*Inrolled in the Inrolment Office, February, 1832.*]

Nobel Inventions.

The Thermidryum.—Mr. Samuel Gray, of Princes Street, Leicester Square, surgical instrument maker, has recently invented and introduced to the public a novel apparatus for warming or airing beds, which may also be applied as a sudatory for the purpose of causing extraordinary perspiration in bed, in the event of patients being afflicted with rheumatism, cold, and other complaints of that character. This apparatus is said fully to answer the purpose of a hot air or vapour bath, and as such is strongly recommended to the attention of medical men and the public in general, as its simplicity will render it available without that previous knowledge which the proper administering of a vapour bath requires.

Plate XIII. fig. 10. is a representation of this apparatus, which consists of a spirit lamp *a*, with a wire gauze chimney *b*, having at the top a number of layers of asbestos or wire gauze *c*, to intercept and disperse the heat from the flame of the lamp; *d, d*, is an outer casing or shield, also of wire gauze, which perhaps had better be made with a dome top, to prevent the bed clothes coming into close contact with the chimney of the lamp, as in that case its heat might singe them.

The chimney is mounted on a plate *e*, which screws upon the top of the lamp, and upon this plate is also

fixed the wire supports *f, f*, of the hood or fire shield, and the whole may be removed with the plate, for the purpose of lighting the lamp. When the spirit in the lamp has been set on fire, the chimney and shield must be replaced, as shewn, and the apparatus may then be safely put into the bed, that is, under the bed-clothes, and being so closed in, the air confined under the clothes will become heated to any degree of temperature required, and thereby constitute a hot air bath. This apparatus may be so placed in the bed as to cause the heated air to act upon any particular part of the patient's body or limbs, and will be found to have the most beneficial effects, under proper medical direction.

It appears to us, that if the top of the outer shield were made to take off, any chemical liquid might be placed in an open vessel over the chimney, which would throw off a vapour, and form a perfect vapour bath or fumigator. This would require very little change in the construction of the apparatus, and would be a very desirable modification.

Fire Escape. Mr. Week, brewer, Stockwell, has invented a fire-escape, with which we observe, from the daily press, some very satisfactory experiments were made very recently. It consists of a large sheet of canvass, so disposed as to admit of individuals throwing themselves into it from any height, without the danger of harm.

Improved Lavement Syringe or Stomach Pump.—Mr. Gray has also invented an improvement upon Jukes's stomach pump and lavement syringe, which we consider

to be of great utility. In cases where it may be required to dilute and extract poisons from the stomach, a great inconvenience has been experienced from the liability of the common ball valves becoming choked by any matters that may be drawn from the stomach, which causes considerable delay in the operation, and consequent danger to the patient. This is obviated by the adaptation of a sliding plate valve, which turns upon a pivot in its centre. Plate XIII. fig. 10, shews the general construction, the syringe; *a*, is the pipe, which is commonly called the suction, or the pipe by which the liquor to be injected is drawn from the bowl or basin; *b*, is the aperture by which it is discharged through the tube *c*, into the stomach or bowels; *d*, is the handle of the piston, to be raised and depressed as usual; *e*, is a thumb-piece, by which the apertures of the valves are opened and closed.

Fig. 11, represents upon a larger scale the internal appearance of the plate, which acts upon a similar plate at the bottom of the cylinder of the syringe, constituting the sliding double valve; and fig. 12, is a section of the same, with the entrance and exit apertures. In this figure the aperture for the pipe *a*, is seen open; when by raising the piston, the liquid will flow into the syringe. Now let the thumb-piece, which is attached to the valve plate *f*, be moved, and the valve plate will turn round upon its central pivot, closing the aperture of the entrance pipe *a*, and opening that of the exit pipe *b*, so that the contents of the syringe may be immediately injected into the body of the patient.

When the contents of the stomach or bowels are to be drawn away, the pipe *b*, becomes the suction, the aperture *a*, being closed, the contents of the syringe are discharged through the pipe *a*, by turning the valve plate round by the thumb piece as before described.

Literary and Scientific Intelligence.

Roman Coins. At least five thousand Roman coins of various periods, weighing six and thirty pounds, have been lately found at Silly in France, in the department of Ome. The mode of their discovery was singular: two or three pieces of silver were observed by some labourers to be turned up to the surface of the earth by moles; this induced them to dig, and at the depth of only a foot, they came to a broken vase of red clay filled with the treasure.

The Pine. A pine-tree has been discovered in the Unapqua country, to the southward of the Colombia, the circumference of which is fifty-seven feet, its height two hundred and sixteen feet without branches!

Royal Society of Literature. A meeting of the committee of this Society (in which we feel peculiar interest) took place lately at their new house in St. Margaret's Place, when the various necessary arrangements were made for opening the ensuing session.

New Musical Instrument.—At a recent sitting of the Academy of Science in Paris, M. Cœgnard Latour read a paper on the subject of a new musical instrument of his own invention, which he calls “the Syren” (la Syrine). It is a sort of flute, in which the sonorous vibrations are produced by the action of a current of water, as in the common flute by a current of air.

A Publication entitled "The Mythology of the Hindus," is announced, with notices of various Mountain and Island Tribes, who inhabit the two peninsulas of India, and the neighbouring islands. By Chs. Coleman, Esq.

Fossil Forest discovered near Rome. In the Edinburgh new Philosophical Journal for last month (January), conducted by professor Jameson, there is a notice of an interesting discovery which has been made by a pedestrian tourist, namely that of a fossil under-ground forest, above forty feet in thickness, and extending for several miles along the banks of the Tiber close to Rome. The petrific matter is a calc-sinter, and from the layers of ligneous débris being freely intermixed with volcanic dust, the discoverer of this interesting circumstance thinks there can be little doubt but that this colossal phenomenon was occasioned by an earthquake, of which the memory is lost; probably long prior to the foundation of Rome. It is singular that so curious a fact should have escaped observation for so many ages.

The Gigantic Book.—The following curious and interesting (to the march of science) paragraph appeared in the Literary Gazette lately, translated from *Le Globe* of the 19th ult. :—

"The largest book that ever went to press will appear next year in London. It will be entitled 'the Pantheon of English Heroes.' Every page will be twenty-four feet high, by twelve broad, and the letters will be half a foot long. It has been necessary to construct a machine expressly for the fabrication of a paper. This gigantic work will be printed by means of a steam engine; and

instead of black ink, gold varnish will be used. Only a hundred copies will be struck off; intended as the ornaments of the principle English libraries!!! We consider this to be a French hoax.

Literature and Art.—By a paper just issued, containing lists of the new books and principal engravings published in London during the past year, it appears that the number of new books is about 1100, exclusive of new editions, pamphlets or periodicals; being 50 less than in 1830; the number of engravings is 92, including 50 portraits; the number of engravings published in 1830 was 107, including 49 portraits.

Fire Escape.—One of a very simple construction was lately suggested by Mr. Charles M. Willich, to the Society of Arts. The idea is not new, as blankets have been often used with success; but if the plan pointed out by Mr. W. were adopted, and a system established, many lives might be saved. It consists of a horse-hair net, about 14 feet long, by 8 feet wide. He recommended that every police station should be furnished with one, which on an alarm of fire should be immediately brought to the spot. The manner of using the net is self-evident. There are always a sufficient number of persons present, who would hold it extended. Horse-hair is recommended, on account of its durability and elasticity. A fire escape must be *always* perfect, and at hand speedily, or it is useless.





ON THE FRICTION AND RESISTANCE OF FLUIDS. BY
GEORGE RENNIE, Esq., V.P.R.S.

[Read before the Royal Society, June, 1831.]

(Continued from page 217.)

Experiments on the Quantities of Water discharged from Rectangular and Triangular Orifices in brass plates one sixtieth of an inch thick, and of equal areas, from a vessel kept constantly full, and at different heights.

TABLE VI.

Equilateral Triangle whose area is one inch, and angle uppermost.				
Height of surface above the centre of orifice.	Time in discharging one cubic foot.	Theoretical time in discharging one cubic foot.	Ratio of real to theoretical discharge.	Form of orifice.
		$\frac{Q}{2 A \sqrt{g} H}$		
feet.	secs.	seconds.		
4	15	8.9	1 : .593	Vena contracta about half an inch beyond the orifice ; but the jet with the angles reversed, and taking the sides of the triangle, the jet afterwards expanded and lost its form. 
3	18	10.3	1 : .572	
2	22	12.7	1 : .577	
1	30	17.9	1 : .596	
Equilateral Triangle as before, with the angle downwards.				
4	15	8.9	1 : .593	Vena contracta the same as before, but the jet having its angle upwards, being the reverse of the former experiments. 
Rectangular Orifice of one square inch.				
4	15	8.9	1 : .593	Vena contracta about three quarters of an inch beyond the orifice, when each angle of the jet took the place of a side thus, and dissipated in spray. 
3	17	10.3	1 : .606	
2	20	12.7	1 : .635	
1	29	17.9	1 : .617	
Rectangular Orifice 2 inches long, $\frac{1}{2}$ an inch wide, having the long side parallel to the surface of the water.				
4	15	8.9	1 : .593	Vena contracta as before. Each angle of the jet took the place of a side. 
3	17	10.3	1 : .606	
2	20	12.7	1 : .635	
1	29	27.9	1 : .617	
Rectangular Jet $1\frac{1}{2}$ inch long, $\frac{1}{4}$ wide, placed as before.				
4	15	8.9	1 : .593	Vena contracta as before. 
3	17	10.3	1 : .606	
2	19	12.7	1 : .668	
1	27	17.9	1 : .663	

Remarks.

That with equal areas, the expenditure by different orifices, whether circular, rectangular, or triangular, is nearly the same, the increase being in favour of rectangular orifices.

TABLE VII.

Experiments on the Quantity of Water discharged by Cylindrical Glass Orifices and Tubes, from one inch in length to one foot, and of different diameters, from a vessel kept constantly full, and at different heights.

Height of surface of water above centre of orifice.	Time in seconds in discharging one cubic foot.				Remarks.
	1 inch.	$\frac{3}{4}$ inch.	$\frac{1}{2}$ in.	$\frac{1}{4}$ in.	
feet.					
4	11.5	21.5	55	145	In comparing these experiments with the time and quantity discharged by plate orifices, there is a diminution of time, and an increased discharge of from one-fifth to $\frac{1}{4}$.
3	15.0	28.5	63	157	
2	17.5	35.0	77	205	
1	25.0	53.0	110	297	
From Glass Tubes one foot long.					
	1 inch.	$\frac{3}{4}$ inch.	$\frac{1}{2}$ in.	$\frac{1}{4}$ in.	
4	14.0	30	63	200	Shows an increase of time and a diminution of discharge in the ratio of from $\frac{1}{2}$ to $\frac{3}{4}$.
3	17.0	33	73	227	
2	21.5	40	88	283	
1	30.0	58	130	410	

Conclusions.

1. That the quantities discharged in equal times by orifices and additional tubes, are as the areas of the orifices.
2. That the quantities discharged in equal times by the same additional tubes and orifices under different heads, are nearly as the square roots of the corresponding heights.
3. That the quantities discharged in equal times by the different additional tubes and orifices under different heights, are to one

another in the compound ratio of the areas of the apertures, and of the square roots of the heights.

From the foregoing experiments the mean coefficient for altitudes of 4 feet with the circular orifices, is 0.621

but with altitude of 1 foot the coefficient is 0.645

with triangular orifices at 4 feet altitude 0.593

with triangular orifices at 1 foot altitude 0.596

with rectangular orifices at 4 feet altitude 0.593

with rectangular orifices at 1 foot altitude 0.616

Hence, allowing for the inaccuracies incident to experiments of this nature, we may safely adopt Messrs. Crony and Bossut's coefficients for altitudes of 4 feet 0.621

— — — — — 1 foot 0.619

In the case of additional tubes of glass the coefficient is much higher than Bossut's, which was for 4 feet 0.806. and 1 foot 0.817.

Note.—Vide Venturi and Eytelwein's experiments.

Let A = area of orifice in square feet.

d = diameter of orifice if circular.

H = altitude of the fluid in feet.

T = time.

g gravity in one second.

According to Bossut's experiments $Q = 0.61938 \text{ at } \sqrt{2gH}$.

And as $2g$ is a constant quantity, and is equal to 7.77125, we have $Q = 4.818 A T \sqrt{H}$ for orifices of any form, substituting d if circular, or $Q = 3.7842 d^2 T \sqrt{H}$.

From the second of these quotations we obtain

$$A = \frac{Q}{4.818 T \sqrt{H}} \quad T = \frac{Q}{4.818 A \sqrt{H}} \quad \text{and} \quad H = \frac{Q}{(4.818 A T)^2}$$

For additional tubes the equation will stand thus: $Q = 0.81 AT \sqrt{2gH}$; but since $2g$ is constant, and is 7.77125, we have $Q = 4.9438 d^2 T \sqrt{H}$, from which we deduce

$$d = \sqrt{\frac{Q}{4.9438 T \sqrt{H}}} \quad T = \frac{Q}{4.9438 d^2 \sqrt{H}} \quad H = \frac{Q}{(4.9438 d T)^2}$$

TABLE VIII.

Experiments on the Friction or Quantity of Water discharged by Leadens Pipes of different diameters and lengths, from a vessel kept constantly full, and at different heights.

Pipes 15 feet long each, straight.					
Height of sur- face of water above centre of pipe.	Time in discharging one cubic foot.				Remarks.
	1 in.	$\frac{3}{4}$ in.	$\frac{1}{2}$ in.	No leaden pipes to be had $\frac{1}{4}$ bore.	
feet.	secs.	secs.	secs.		
4	28	54	143		The time in discharging one cubic foot is nearly double the time occupied by glass tubes of equal lengths and areas.
3	33	63	164		
2	41 $\frac{1}{2}$	79	208		
1	61 $\frac{1}{2}$	117	312		

TABLE IX.

Experiments on the Quantities of Water discharged by Leadens Pipes $\frac{1}{2}$ inch bore, but of different lengths from one foot to thirty feet in length.

Glass tubes 1 inch long, $\frac{1}{2}$ inch diam.		Brass orifice $\frac{1}{2}$ diam.	1 foot long.	3f. 9in.	7f. 6in.	11 f. 3 in.	15 ft.	30 ft.
ft.	secs.	secs.	secs.	secs.	secs.	secs.	secs.	secs.
4	55	73	55	78	102	122	143	203
3	63	83	63	92	120	145	164	240
2	77	104	93	113	151	184	208	303
1	110	144	133	170	226	276	312	450

Remarks:—The ratio of discharge by glass tubes with pipes of 30 feet long, is as 1 : 4 - - - nearly.
Ditto with brass orifices, is as 1 : 3 - - - nearly.

Conclusions on Pipes of different Lengths.

That the expenditures of water by pipes of equal diameters, but of unequal lengths and under different altitudes, are nearly as follow:—

The length being as 30 to 1, the expenditures are as 3.7 to 1
Do. 8 to 1 do. 2.6 to 1

Do..... 4 to 1 do..... 2 to 1

Do..... 2 to 1 do..... 1.4 to 1

The discharges by glass and leaden tubes are nearly alike. The length of a pipe may be increased from 3 to 4 feet without diminishing the discharge as compared with the plate orifices.

TABLE X.

The straight pipe of $\frac{1}{2}$ an inch bore, on which the preceding experiments were made, was carefully bent into one, two, and fourteen semicircular bends respectively, each of $7\frac{1}{2}$ inches in the semi-diameter, and two of $\frac{1}{4}$ th part of a circle of $3\frac{1}{4}$ inches radius. One end of the pipe was fixed in the wooden orifice as before, and the following are the results,



Pipe 15 feet long, $\frac{1}{2}$ inch bore, with one semicircular and two $\frac{1}{4}$ -circle bends.

Height of surface of water above the centre of orifice.	Time in discharging one cubic foot by a pipe with 3 bends.	Time in discharging one cubic foot by a straight pipe.	Remarks: The position of the bends, whether vertical or horizontal, at either extremity of the pipe, does not affect the result.
feet.	secs.	secs	
4	147	143	
3	175	164	
2	213	208	
1	316	312	



Pipe 15 feet long, $\frac{1}{2}$ inch bore, with 14 semicircular and two $\frac{1}{4}$ -circle bends.

	seconds.	seconds.	The expenditure is diminished by the bends from 1-5 to $\frac{1}{2}$, which represents the friction of the pipe.
4	162	143	
3	200	164	
2	247	208	
1	351	212	

Results.

1. That with one semicircular and two $\frac{1}{4}$ of a circle bends, as compared with a straight pipe of equal length and bore, the resistance varies from one-36th to one-70th part of the resistance of the straight pipe.

2. That within fourteen semicircular and two quarters of a circle bends, the resistance varies from one-19th to one-39th of the resistance of a straight pipe.

3. That the increased number of bends does not increase the resistance in the ratio of the number of bends, but merely shows an increased resistance, as compared with the four bends, of one-14th to one-35th.

TABLE XI.

Experiments on the Discharge of Water by Leaden Pipes of $\frac{1}{2}$ an inch bore, 15 feet long, but bent in the forms of from one to twenty-four right angled elbows, each side being $6\frac{3}{4}$ inches long.

Height of surface of water above centre of orifice.		One right angle $8\frac{1}{4}$ inches from the end of the pipe.	Straight pipe 15 feet long.	Twenty-four right angles.	Remarks.
feet.	secs.	secs.	secs.	secs.	In the first three experiments we have a diminution of expenditure in the ratio of $2\frac{1}{2}$ to 1, and in the last experiment as 3 to 1 nearly.
4	180	395	365		
3	214	465	465		
2	210	584	584		
1	371	872	872		



Conclusions.

From the foregoing experiments with one rectangular pipe, it would be reasonable to conclude that the diminution of discharge would be as the number of right angles; but comparing the expenditure by one right-angled pipe with the expenditure of a pipe with twenty-four right angles, the difference is only in the ratio of about two to one.

General Remarks on the Expenditure of Horizontal and Bent Pipes.

Formulae adapted to the different circumstances of the motion of water in pipes and conduits have been given by various authors.

By some, the retardations were supposed to be in the inverse ratios of the squares of the lengths of the pipes; and by others, to be represented by a certain portion of the altitude of the reservoir above the centre of the pipe, the resistance being directly as the length and circumference of the pipe, and inversely as the area of the section.

M. Girard, in his beautiful experiments,* conceived the resistance to be compounded of the first and second powers of the velocity. So that, deducing the values from Dubuat's experiments, and expressing the resistance due to cohesion by $R \times U$, R being the quantity to be obtained by experiment, and making the resistance due to the asperities equal to $R \times U^2$, the sum of the resistance is $R (U + U^2)$.

M. PRONY, applying his profound acquirements to the solution of all the cases of preceding authors, deduced from a selection of upwards of fifty experiments the following simple formula: —

$$U = 26.70 \sqrt{\frac{D Z}{\lambda}};$$

U being the mean velocity of the section of the pipe;

D the diameter of the pipe;

Z the altitude of the water;

λ the length of the pipe:

from which it appears that the velocity is directly in the compound ratio of the square roots of the diameter of the pipe and head of water, and inversely as the square roots of the length of the pipe; that is, for any given head of water and diameter of pipe, the velocity is inversely as the square root of the length of the pipe.

If we compare these results with those of Dubuat, Girard, and others, they approximate very nearly to each other.

* *Memoires des Scavans Etrangers.*

In general, if we incline a pipe to an angle of about $6\frac{1}{2}$ degrees, or one ninth of its length, the discharge will be nearly equal to the discharge by additional tubes. The charge necessary to express the mean velocity of water issuing from straight pipes is

by some authors equal to $\frac{V_2}{478}$;* Dr. Young makes it $\frac{V_2}{550}$; the

diminution of expenditure depending upon the contraction of the fluid vein and the friction of the pipe.

The change occasioned by bends and angles in the direction of the fluid vein tends to diminish the velocity in a very remarkable manner.

Dubuat undertook several experiments upon this subject, but the formula proposed by him does not solve the difficulty, where

$\frac{V^2 S^2}{m}$ gives the resistance due to one bend, V being the velocity,

S the sine of incidence or reflection, and m a constant quantity determined by Dubuat to be 2998.50.

Now although it is reasonable to suppose that the resistance should be proportionable to the squares of the sines of the angles of incidence, yet as all the particles of the fluid vein are not reflected in the same angle, and as a considerable portion of the velocity is destroyed by the first angle or bend the fluid meets with in the pipe, M. Dubuat's theory is fundamentally erroneous, the more especially as he has rejected more than one half of the twenty-five experiments mentioned by him. Dr. Young's suppositions, of the resistance being as the angular flexure and the power of the radius, of which the index is $\frac{7}{8}$, are equally erroneous, as is evinced by the foregoing experiments.

In conclusion, it is evident that the subject of friction admits of an immense variety of applications. To determine the measure of the resistances experienced by vessels and floating bodies in their motion through fluids; the law of the retardations of rivers, and the cause of the obstructions* presented to the waves

* DUBUAT and LANGSDORFF.

of the ocean in the slopes assumed by its shores ; the equilibrium of earths, and their connections with solids and fluids—all of them are questions of the utmost importance in the economy of nature, and their solution can only be attained by an accumulation of facts.

N. B. Since the foregoing was presented to the Royal Society, an abstract of an extensive series of experiments on the expenditure of water through rectangular orifices of large dimensions, has been submitted to the French Academy by Messrs. Poncelet and Lesbros, of the Corps de Genie at Metz ; and as these experiments were undertaken by order of the French government, no expense was spared to have them made as extensive as possible. Their objects were principally to ascertain the exact measure of the coefficient of contraction and the forms of the fluid veins under different altitudes and areas.

The results of which are :—

That with an orifice of 20 centimetres square, the coefficient is 0.600 under altitudes of 1 metre 68 centimetres. But when the altitude was reduced to four or five times the opening of the orifice, the coefficient increased to 0.605, but again diminished rapidly as the altitude diminished, to 0.593.

That with orifices of smaller dimensions, i. e. from 10 to 5 centimetres square, the same law was observed, the coefficient, being respectively 0.611, 0.618, and 0.611, for opening of 10 and for 5 centimetres, 0.618, 0.631, 0.623 ; and for orifices of less dimension, the coefficient continually increased up to 0.698.*

That for water running over weirs, the mean coefficient was 0.400, which differs very little from that of Bidone.

Hence we see little reason to deviate from the coefficients already given.

A P P E N D I X

To the Report of the Select Committee of the House of Commons, on Patents.

Papers delivered in by John Farey, Esq.

[*British Law of Patents for Inventions.*]

(Continued from page 227.)

ON a motion being afterwards made for a new trial, it was argued before Easter Term 1821, and a new trial granted, on the ground that the patent was void, because the anchor was not a new invention.

Lord Chief Justice Abbott: It is with great reluctance, that my mind has at length come to a conclusion which (as far as my judgment goes) will have the effect of avoiding this patent. It appeared in evidence, that the mode of making chain cables and anchors, introduced by the plaintiff into general use, is highly beneficial to the public, and I wish he could sustain his patent. I feel compelled to say, that the anchor is not new, and that the whole patent is therefore void.

The shank of the anchor is united to the two arms in the same manner as the handle is united to the head of a pick-axe; and that mode of union has been before used, to affix the shanks to the heads of mushroom anchors, and also adze anchors. A patent for a machine, each part of which was in use before, but in which the combination of the different parts is new, and a new result thereby produced, is good: because there is novelty in the construction; but in this case, ships anchors are commonly made of the shank and two arms, united in three pieces; plaintiff forms the two arms in one piece, with a hole through them, to receive the end of the shank, which is put through, and the end rivetted. If the union of those two pieces had been effected in a mode unknown before, as applied in any degree to a similar purpose, I should have thought it a good patent, but unfortunately it was known and practised before. A patent cannot be maintained for uniting two parts instead of three, where the union is effected by a mode known before for a similar purpose. If the patent had been for this anchor alone, I should have had no hesitation in declaring it bad.

As to the chain cable, I think the combination of a link of that particular form, with the stay of the form which the plaintiff uses, although the form of the link might have been known before, is so far new and beneficial as to sustain a patent, if it had been

for that alone : but as one of the articles is not new, the question arises whether any part of the patent can be sustained.

A patent cannot extend beyond the consideration of the grant ; the king could not, in consideration of a new invention in one article, grant a patent for that new article and another which was not new. If a party, by representing to the Crown that he has discovered improvements in three things, obtains a patent for the three, and in the result, it turns out that there is no novelty in one of them, can he sustain his patent? The case of *Hill v. Thompson* is decisive ; Hill's patent was for certain improvements in smelting and working iron. The improvement in smelting iron was obtaining bar iron from the slag which had been before thrown away as useless. The improvement in working iron, was the application of lime in certain stages of the process, to cure a disease common to all iron, not merely to that which was to be obtained by the first improvement. It was proved, that the latter was not new, and the Court of Common Pleas held, that admitting there was novelty in one, yet as there was no novelty in the other, the patent was void.

The only difference between that case and the present is, that Brunton, instead of representing that he had made certain improvements, stated what they were applicable to ; but he claims the merit of having invented three, and the patent was granted upon consideration of the entirety of the improvement of the three ; and if there is no novelty in one, the consideration fails in the whole, and the patentee is not entitled to the benefit of the other. There must therefore be a new trial.

Mr. Justice Bayley : I think there ought to be a new trial. I have no doubt, that if a patent be bad as to part, it is bad as to the whole. When a patent is taken out for several things, the entire discovery of them all, is the consideration on which the grant is made ; that consideration is entire ; and if it fails in any part, it fails *in toto*. If every part is new, it is a matter of favour in the Crown to make the grant ; and it may be, that the discovery of three things together may form the proper subject for a patent, although each *per se* would not ; therefore, if any part of the consideration fails, the patent is void *in toto*.

If the present patent had been for the chain cable only, I think it would have been good. The improvement in the link is in giving it such a form as will cause the force of the strain to operate end-ways of the iron of which the link is composed, and applying a bar or stay across the opening, to keep the sides apart, that stay being without the defect of those previously used, which were pointed at the ends, and inserted into holes in the sides of the link ; but Brunton's are broad at the ends, and lap round the iron, instead of penetrating into it.

The improvement in ships anchors is making the two arms in

one piece (instead of in two distinct pieces, each to be welded separately to the shank) a hole being left through the middle of one piece, which forms the two arms, to receive the end of the shank. I think a patent cannot be maintained for making in one entire piece that which was before made in two pieces; and plaintiff's mode of uniting the shank to the one piece was used in mushroom anchors and adze anchors; and being so like that used in a pick-axe and hammer, I do not think the mere introducing the shank of the anchor, (which may be called the handle) in so similar a mode, is an invention for which a patent can be sustained. The mushroom anchor and adze anchors, though used as mooring anchors, and not carried with ships, are still ships anchors, and the analogy between them and the plaintiff's is so close, that it does not appear to me that this discovery can be considered so far new, as to be proper ground for a patent; it is nothing more than making in one piece what was before made in two, and introducing the shank into this kind of anchor in the way a handle is introduced into a pick-axe. I think the patent is wholly void, and that there must be a new trial.

Mr. Justice Best: I am of the same opinion. In the case of *Hill v. Thompson*, the Court of Common Pleas, with great reluctance, came to the conclusion, that a patent taken out too large, is void, not only for the excess, but altogether. Respecting this case, the Lord Chancellor had previously said: "The Judge, Mr. Justice Dallas, in his direction to the jury, stated, as the law on patents, that the invention must be novel, useful, and intelligibly described in the specification. I will go further, and say, that the specification must not attempt to cover more than that which, being matter both of actual and useful discovery, is the only proper subject of a patent. If a patentee seeks by his specification any more than he is strictly entitled to, his patent is rendered ineffectual, even to the extent to which he would otherwise have been entitled. A patent may be valid for a new combination of materials previously in use for the same purpose, or for a new method of applying such materials, but the specification must clearly express that it is only for such new combination or application, and not lay claim to the merit of original invention in the use of materials."

When this case was first presented to me, I thought the mooring chain was a new combination of old materials, and that the patent was good; I now doubt that, for the specification cannot stand as a description of a new combination of known principles; it claims the form of the link which is not new; it says, the object to be attained is to get the greatest possible strength from a given quantity of materials; as far as that is to be done by introducing a stay across the link in a new mode, viz. with broad ends, supporting and embracing the sides, it would be new; but he

goes on to say, "that of all forms for the links, that which shall be able to convert a lateral into an end strain, by supporting the opposites sides of the links, is to be preferred:" here I think it claims the merit of originally using links, with stays across, such as have been used long before.

The invention claimed as to the anchor is, that he avoids the welding of the two arms separately to the shank; but his mode of uniting had been used before in the case of mushroom and adze anchors, and in the pick-axe. If he had stated in the specification, that as welding weakens the anchor, he had first applied to the making of ships anchors, that mode of uniting the shank to the two arms, which had been long practised in making other instruments, viz. making the two arms in one piece, instead of two, then it would have been a question whether such an application could be considered a new invention for a patent; but it is unnecessary to consider that question, because he has claimed the mode of avoiding welding, as a new discovery, when it was not new; he has taken his patent for more than he was entitled to, and that avoids the patent *in toto*. The King has been deceived by the representation made by the patentee, that he had the merit of inventing two things, when he had only discovered one: the Crown might have considered the discovery of the two sufficient ground for granting the patent, when the one alone would not have been thought worthy.

In a deed for grant of lands, if it contained three distinct conveyances, of three distinct estates, on three considerations, one might be set aside and another be good; but if the grant were upon one consideration, which was bad, the whole would be void, because the consideration will fail altogether. In this case the consideration to induce the King to grant the patent, was the statement made by the plaintiff in his petition, that he had made three inventions, when in fact he had made only two; the united consideration upon which the whole grant was made, is therefore void, and consequently the grant itself is void. I am of opinion there ought to be a new trial.

Salmon against Hampson. An Action for infringement of Salmon's Patent of 1806, for his self-adjusting Truss, for the relief and cure of Ruptures. Tried in the King's Bench in 1821, before Chief Justice Abbott, Verdict for Plaintiff.

This truss is a most valuable invention, which has proved of the greatest service to many thousands of individuals, afflicted with hernia.

The King against Lodge and Bittleston. A scire facias to repeal their patent of 20th June 1820, for certain improvements in the construction and application of Spring trusses or bandages for the relief and cure of Hernia. Tried in the King's Bench, 25th

October 1822, before Lord Chief Justice Abbott. Verdict for the Crown.

The proceedings were at the suit of Mr. Salmon, who had obtained a patent in 1811, for an invention, which was proved to be substantially the same as that described in the specification of Lodge and Bittleston's patent.

Hall against Gervas and Francis Boot. An Action for infringement of Hall's patent, 3d November 1817, for a method of improving every kind of Lace or Net. Tried in the King's Bench, 17th December 1822, before Lord Chief Justice Abbott. Verdict for the Patentee.

The invention is to extend the lace net horizontally, and draw it by machinery, with a slow and regular motion, over the flames of gas lights, which flames are urged upwards by a current of air rising through a chimney that is fixed over them, and above the lace, so as to draw the flames upwards through the meshes of the lace, in order to singe and burn away all superfluous fibres from the cotton thread, of which the lace is composed, thereby improving the beauty of the lace very greatly.

The infringement was not proved by very direct evidence: but it was proved, that the defendant had set up the business of bleaching and clear starching lace, and ordered the gas company's pipes to be laid into his workshops to supply a certain number of burners, afterwards the arrangement of the pipes was altered, without any assignable cause, and carried into a part of the shop which was partitioned off, and kept very carefully closed; also, a gas-meter having been applied by the gas company to the entrance pipe, that they might be paid according to the quantity of gas consumed, it was observed, that the consumption was excessive for the professed number of burners, or the size of the shops.

In defence, it was proved, that flame of charcoal, or waste paper, had been long used for singeing off the superfluous fibres from lace sleeves, mitts and stockings, but they were always stretched upon a sleeve board, or a wooden leg, during the singeing, and the flame was not urged by the draught of a chimney, so as to burn up through the interstices of the lace, in order to singe withinside of the meshes, which is the essence of Mr. Hall's invention. No objection was raised against the specification. Lord Chief Justice Abbott: "There can be no doubt but the verdict must pass against both the defendants; one of them has the gas pipe laid into his house."

Barber against Walduck. An action for infringement of Barber's Patent of 1821, for an improved manner of making Hats. Tried at Lancaster in the summer of 1823, before Mr. Justice Holroyd. Patentee nonsuited.

The patentees were hat manufacturers; and one of their men, whom they called as a witness, proved, that he himself invented

the improvement which was the subject of the patent, whilst employed in their workshop. Mentioned on the trial, *Bloxam v. Elsee*, 1825.

Note.—Messrs. Barker and Harris had a patent, in 1821, for improvements in the method of cleaning furs and wools used in the manufacture of hats, from kemps and hairs; it is stated Barber in the above report, by mistake.

Savory against Price. An action for infringement of Savory's Patent of 1815, for a method of making a neutral salt, or powder, possessing all the properties of the medicinal spring at Seidlitz, under the name of Seidlitz Powder. Tried in the Court of King's Bench 17th December 1823, before Chief Justice Abbott. The Patentee was nonsuited.

The specification gave three distinct recipes for preparing the ingredients, and then directed two scruples of each of the three ingredients resulting from those recipes to be dissolved in half a pint of water, in order to produce the imitation of Seidlitz water. It was proved by following the directions given in the specification, the result was obtained, and that it was new and useful. It appeared that the three recipes were only common processes for preparing three well known substances, viz. Rochelle salts, carbonate of soda, and tartaric acid, which were sold in shops before the date of the patent; and those three substances being used as directed, constituted the Patent Seidlitz Powder; the specification did not give any name to the ingredients resulting from the three recipes; but gave those recipes without comment, as if they were part of the method of making the Seidlitz powder.

Lord Chief Justice Abbott: "It is the duty of a patentee to specify the plainest and most easy way of producing that for which the patent is granted, and to make the public acquainted with the mode which he himself adopts. By reading this specification, we are led to suppose a laborious process necessary to the production of the ingredients, when in fact we might go to any chemist's shop and buy the same things ready made. The public are misled by this specification, which tends to make people believe that an elaborate process is essential to the invention; it cannot be supported." The plaintiff was accordingly nonsuited.

Morton against Barclay and others. An action in Scotland, for infringement of Morton's Patent of 1818, for a method of dragging Ships out of water on dry land. Tried in the Jury Court at Edinburgh, 15 March 1824, before the Lord Chief Commissioner, Lord Gillies, and Lord Mitmilly. Verdict for the Patentee. The invention is a substitute for a dry dock for repairing ships. It consists of a horizontal frame or very low carriage with rollers, or small wheels adapted to run upon an inclined plane or slip, such as is commonly used for building ships;

also a strong crane work to drag that carriage up the plane, by a chain, when a ship is placed upon the carriage, which can run down the inclined plane so far under water that the ship can be floated over it. A beam which extends along the middle of the carriage, supports blocks on which the keel of the ship is to rest; and there are several cross beams, on which other blocks are fitted in grooves so as to slide to or from the middle beam, in order to adapt them to block up under the bottom of the vessel, and keep her upright on the carriage: these sliding blocks can be drawn into their places under the bottom, as the vessel settles down on the carriage, after the keel is come to rest on the blocks.

The pursuer erected several such patent slips at various places in England and Scotland under his patents, and the defenders made one near Glasgow in infringement thereof; whereupon the pursuer raised an action in the Court of Session; the defenders, in answer, denied any infringement, alleging that their machine was different from the pursuer's. The question was remitted to the Jury Court, where defenders did not appear, thereby admitting the infringement. The merit and utility of the invention was proved by the testimonies of several naval officers, engineers, and ship builder; several of them taken in writing in England on commission.

The Lord Chief Commissioner made some observations as to the law of Scotland in cases of this nature, and that he thought it would be a desideratum to have the point settled. The pursuer's advocate submitted, that since the Union, the practice in regard to patents was the same in Scotland as in England. The Lord Chief Commissioner said, that as the defenders did not appear, the court must suppose their cause indefensible; he had never seen a case before any court more fully made out than the pursuer's. The practice in England rendered it necessary for the pursuer to make out, 1st. That the invention was original, and was made by the patentee himself; 2nd. That his patent right had been invaded. In this case it had been proved that the invention was original; that it was useful, and preferable to dry docks; that it would be of the utmost utility in places where there was not a rise and fall of tide; that the shipwrights working in the dry, may work longer days than in a dock, and can more conveniently use long planks. With regard to the law in questions of this nature, he would say nothing; he believed that this was the first case which had been brought to trial upon similar issues. No amount of actual damage had been proved, and it was only a question of the right. The jury found a verdict for the pursuer, with one shilling damages and costs.—Printed Notes of the Trial.

Bloxam and another, assignees of H. and S. Fourdrinier, bankrupts, against Elsee. An action for Infringement of Gamble's

Patents of 1801 and 1803, for a Machine for making Paper. Tried in the King's Bench, before Chief Justice Abbott, 18th Jan. 1825. Verdict for the Patentees.

The machine acts by the continuous motion of an endless web of woven wire cloth, circulating over horizontal rollers, and forming a moving horizontal plane, on which the pulp is spread at one end, and during the motion thereof, as the pulp advanced to the other end, it is formed into a tissue of paper, which is taken off in a continuous sheet at the other end of the moving plane.

(To be continued).

New Patents Sealed, 1831, 32.

To John Samuel Dawes, of Bromford, in the parish of West Bromwick, in the county of Stafford, iron master, for his invention of certain improvements in the manufacture of iron.—22d December, 1831, for Inrolment.—6 months.

To John Dickinson, of Nash Mill, in the parish of Abbott's Langley, in the county of Hertford, esq. for his having invented or found out certain improvements in the manufacture of paper.—10th January, 1832.—6 months.

To William Sneath, of Ison Green, Nottingham, lace maker, for his having invented or found out certain improvements in machinery for the manufacture of bobbin net lace.—21st December.—6 months.

To John Lihou, of the Naval Club House, Bond Street, in the county of Middlesex, esq. a commander in our royal navy, for his having found out and invented an improved method of constructing capstans.—10th Jnnuary, 1832.—6 months.

To Moses Teague, of Park End Iron Works, near Calford, in the county of Gloucester, iron master, for his having invented certain improvements in making and smelting pig iron.—17th January.—4 months.

To Elijah Galloway, of Blackfriars Road, in the county of Surrey, engineer, for his having invented certain improvements on paddle wheels.—17th January.—4 months.

CELESTIAL PHENOMENA, FOR FEBRUARY, 1832.

D.	H.	M.		D.	H.	M.	
1	10	15	☉ eclipsed invisible	20	0	0	Clock before the ☉ 14 m. 8 s.
1	10	16	Ecliptic conj. or ● new moon	20	0	0	♃ 23 h. 15 m. R. A. 13. 34. S. dec
1	18	0	♀ in conj. with ♂ long. 0. 4. Cap. ♂ 20. S. lat. ♀ 8. N. lat. diff. of lat. 28.	20	0	0	♃ 10 h. 12 m. R. A. 3. 55. N. dec
2	0	0	☉ rises 7 h. 26 m. sets 4 h. 36 m.	22	0	0	♃ 8 h. 17 m. 25. 3. N. dec
2	21	0	♃ in conj. with ♃ lon. 29 in Cap. ♃ lat. 1.35 S. ♃ lat. 54 S. diff. of lat. 41	22	0	0	Pallas 21 h. 48 m. 0. 7. S. dec
2	0	0	♃ greatest elongation W. 25 26.	23	0	22	☾ in ☐ last quarter
3	17	45	conj. ☉ and ♃	23	0	0	☉ rises 6 h. 48 m. sets 5 h. 12 m.
5	0	0	Clock before the ☉ 14 m. 19 s	23	12	0	Mer. in conj. with ♃ long. 13. in Cap. Mer. lat. 1. 47 S. ♃ lat. 39 S. diff. of lat. 1. 8
6	0	0	♃ 22 h. 55 m. R. A. 15. 45. S. dec	25	0	0	Clock before the ☉ 13 m. 28 s.
6	0	0	Pallas 21 h. 27 m. R. A. 0.57. S. dec	25	10	0	☾ in Apogee
6	0	0	♃ 10 h. 23 m. R. A. 1. 46. N. dec.	26	0	0	♃ 10 h. 7 m. R. A. 4. 56. N. dec
6	0	0	Vesta 8 h. 32 m. R. A. 24. 14. N. dec	26	0	0	♃ 8 h. 15 m. R. A. 23. 42 N. dec
8	23	13	♃ in ☐ first quarter	26	0	0	Pallas 21 h. 53 m. R. A. 0. 7. N. dec
9	0	0	☉ rises 7 h. 15 m. sets 4 h. 45 m.	26	0	9	♃ 23 h. 24 m. R. A. 12. 36. S. dec
10	0	0	Clock before the ☉ 14 m. 35 s.	27	8	0	Mer. in conj. with ♃ in Cap.
10	5	0	occultation of Aldebaran by the moon's southern limb	27	13	30	☾ in conj. with ♃ long. 1. 6. = an occultation touching the moon's southern limb ☾ lat. 0. 54. N. ♃ 0. 30. S
13	0	0	♃ in perigee	29	0	0	☉ rises 6 h. 36 m. sets 4 h. 24 m.
13	9	0	♀ in conj. with ♁ in Sag	22	1	0	☾ in conj. with ♃ long. 15 in Cap. ☾ lat. 16 S. ♃ lat. 39 S. diff. of lat. 23
15	0	0	Clock before the ☉ 14 m. 30 s.	29	20	0	☾ in conj. with Mer. long. 23 in Cap. ☾ lat. 1. 12. S. Mer. lat. 2. 5. S. diff. of lat. 53
15	0	0	☉ rises 7 h. 3 min. sets 4 h. 57 m.				
15	15	19	Ecliptic oppos. or ○ full m.				
15	16	0	☾ in conj. with Regulus oc- cultation under southern limb				
16	18	38	☾ in conj. with ♃ long. 12. in Leo. ☾ lat. 2. 38 N. ♃ lat. 2. 6 N. diff. of lat. 32.				
17	0	0	♃ in Aphelio				
18	21	0	♃ in conj. with ♁ in Sag.				
19	2	5	☉ enters Pisces				

Jupiter's satellites not visible this month,
owing to the planet being so nearly in the
same part of the heavens as the sun.

The waxing moon ♃.—the waning moon ☾

J. LEWTHWAITE.
Rotherhithe.

Meteorological Journal, 1832.

1831.	Thermo.		Barometer.		Rain in in- ches.	1832.	Thermo.		Barometer.		Rain in in- ches
	Hig.	Low	Hig	Low			Hig.	Low	Hig.	Low.	
DEC.						JAN.					
26	39	24	30,39	30,35		10	49	36	29,64	29,51	,25
27	40	34	30,83	30,27		11	48	39	29,73	29,61	,025
28	41	30	30,27	30,20		12	46	33	29,72	29,56	,125
29	43	32	30,17	30,12		13	41	35	29,74	29,50	,425
30	41	25	30,34	30,20		14	37	27	30,23	30,03	,025
31	37	22	30,30	30,16		15	36	21	30,38	30,34	
1832.						16	35	21	30,36	30,32	
JAN.						17	41	30	30,26	30,23	
1	33	20	30,16	30,12		18	42	28	30,26	30,25	
2	37	21	29,92	29,80		19	34	23	30,26	30,20	
3	32	27	29,76	Stat.		20	34	23	30,11	Stat.	
4	32	16	29,68	29,61		21	41	29	30,16	30,07	
5	30	20	29,63	29,61		22	43	32	30,16	30,15	
6	39	29	29,58	29,42		23	42	33	30,24	30,14	
7	41	33	29,35	29,33		24	46	24	30,14	30,09	
8	40	32	29,39	29,33		25	47	37	29,76	29,74	
9	43	32	29,45	29,37							

Edmonton.

Charles Henry Adams.

Latitude 51° 37'—32' N.

Longitude 3°—51' West of Greenwich.

It is rather extraordinary that snow has not been found to lie in London once this winter, up to the present time—such has been the mildness of the season.

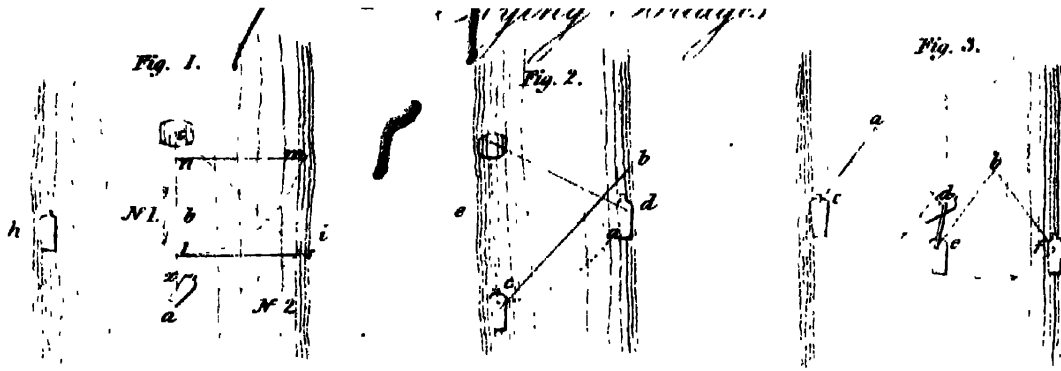

Frankenburg's. Maschine für Splittung. Holzes.

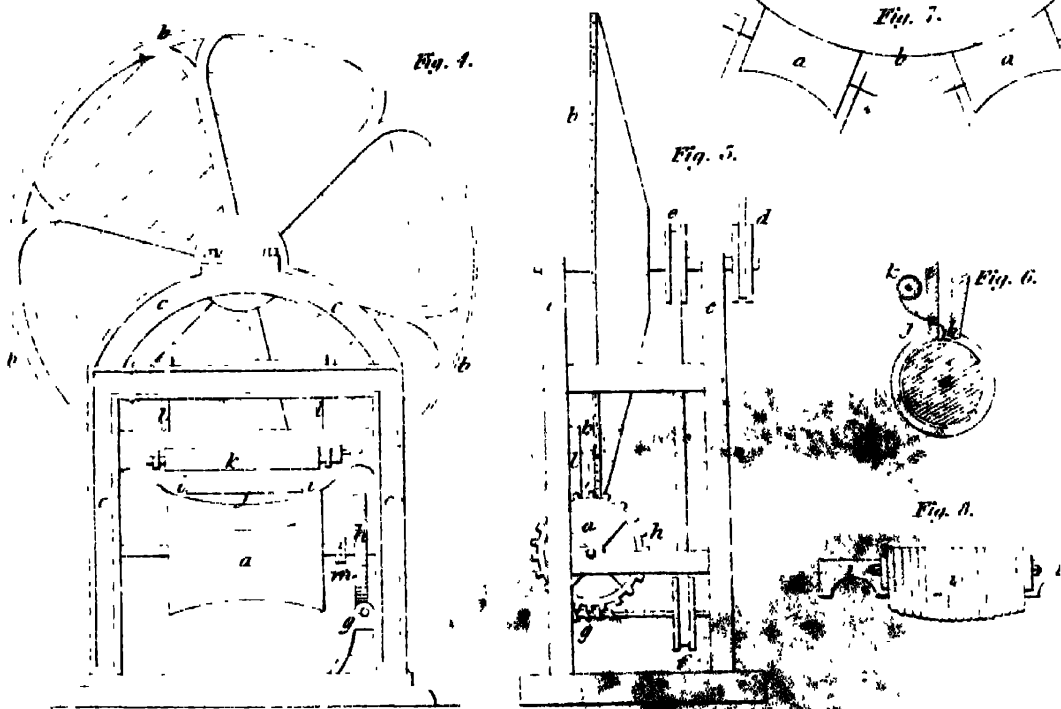

Morgan's. Imp'ion. Steam Engine.

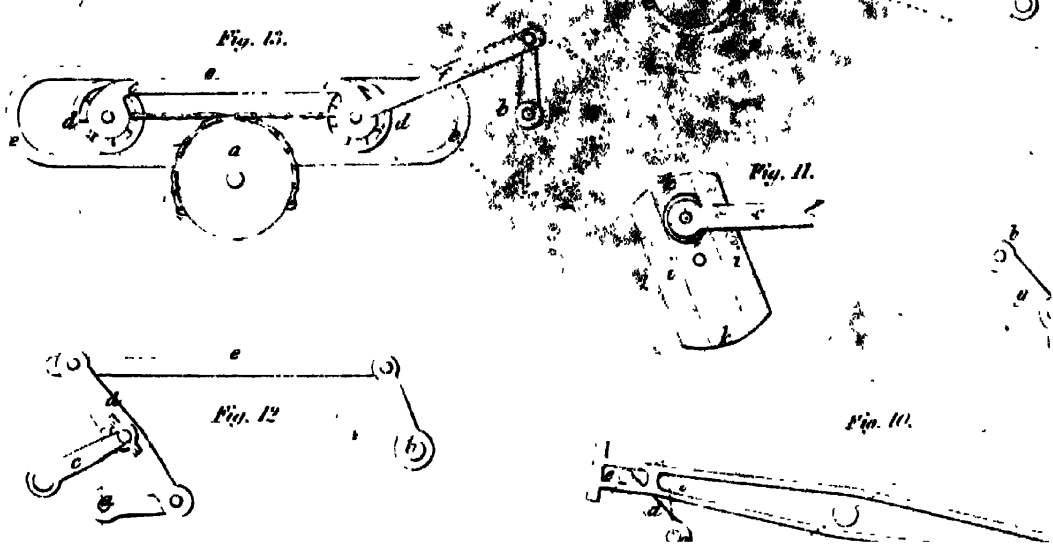

SECOND CLASS
Viney's *Impr'd Steam Boilers*

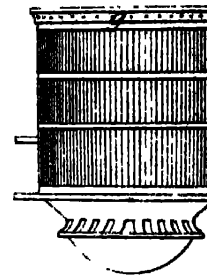
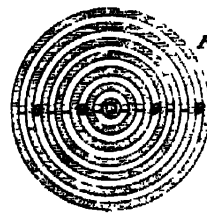
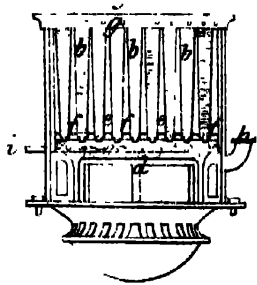

Impr'd Cooking Apparatus

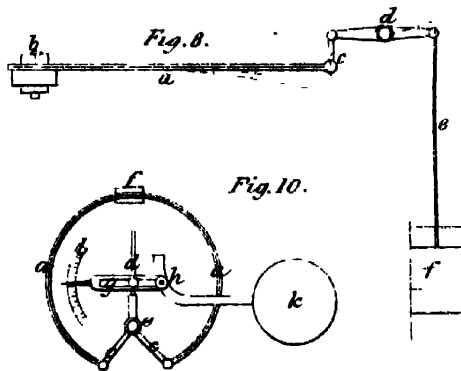
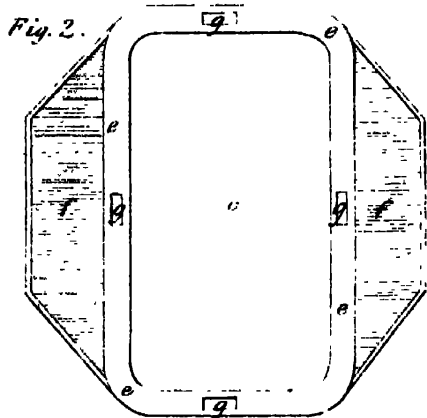
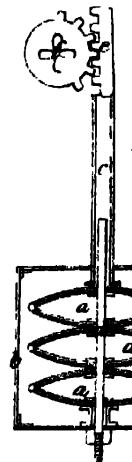
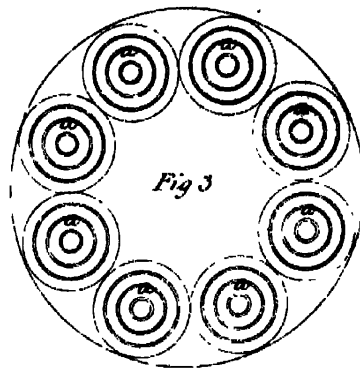
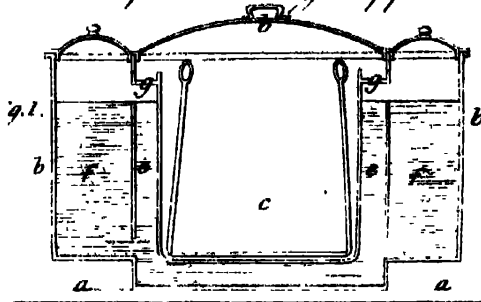

Fig. 1.



Wm. Armstrong's Distilling Apparatus

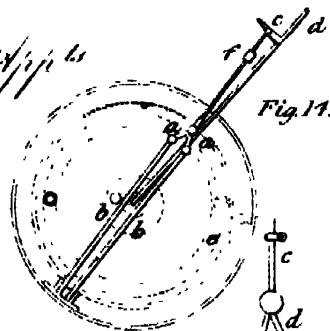
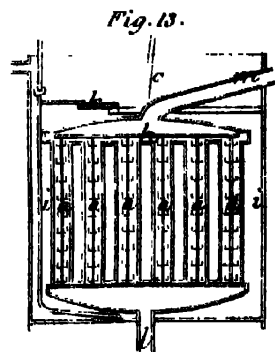
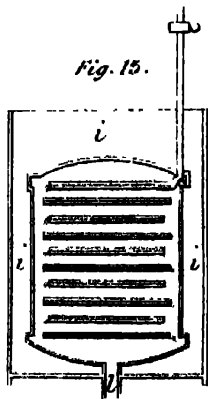

Fig. 12.

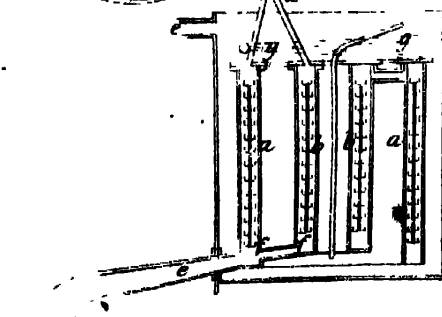

Fig. 16.



THE
London
JOURNAL OF ARTS AND SCIENCES.

No. XLVIII.

[SECOND SERIES.]



Original Communications.

ON FLYING BRIDGES.



To the Editor of the London Journal of Arts, &c.

SIR,—Flying Bridges are rarely if ever used in this country, because whenever there is any intercourse between the opposite banks of a river, it is generally sufficient to justify the erection of a permanent bridge, and the breadth of our rivers is not in general such as to render the construction of permanent bridges impracticable; moreover, where they are broad, they are seldom rapid enough to prevent a ferry boat from crossing with tolerable ease and expedition.

From their simplicity and cheapness, and the expedition with which they can be constructed, flying bridges are of great use in military operations; they are also very common on the broad and rapid rivers of the continent, and although little used in England, are not undeserving of attention.

A flying bridge is formed by fastening a floating body to the end of a cable or chain, moored in a river, and keeping the body by a rudder, oblique to the direction of the stream; the action of which against the oblique side of the floating body, drives it away towards one of the banks, moving it in an arc of a circle, about the moorings of the cable.

Plate XIV. fig. 1, represents a floating bridge; *a*, a boat fastened by a cable *b*, to a buoy or an anchor at *c*. The current running in the direction of the arrow No. 1, moves the boat *a*, in an arc of a circle about *c*, away from the bank *h*, towards the bank *i*.

The force which urges the boat *a*, in the direction *h*, *i*, depends upon the obliquity of the boat to the current, and is greatest when the side *x*, makes with it an angle, of $54^{\circ} 44'$.*

A bridge of this kind is in use on the Rhine, for crossing opposite Nymuegen. From the bank opposite to Nymuegen, a bridge of boats is built, extending rather more than half across the river. The flying bridge is a platform or piece of road, laid on a strong barge, to which one end of a chain is made fast; the other end of the chain carried over and fastened to the masts of seven boats, to support its weight, and is moored in the river at some distance up the stream. The barge is steered oblique to the stream, and according to the direction of its obliquity, swings round in an arc of a circle, from the end of the bridge of boats to a jetty on the Nymuegen bank, or *vice versa*. The stream runs about three to three and a half miles an hour.

In very rapid rivers, flying bridges should not be made both to cross and re-cross by the action of the current, for the resistance to the motion of the boat in the ascending part of the arc (viz. in the direction of the arrow,

* Vide Douglas on Military Bridges, p. 94.

No. 2,) is very great, and the descending force of the stream, to drive the boat down the river, negatives the effect of its oblique action on the boat, to drive it upwards about the moorings of the cable.

In such cases, it is advisable to make the flying bridge move only one way by the current, viz. in a descending arc, and to haul it back by a second cable; thus the boat *a*, fig. 2, crosses to the bank *e*, through a descending arc from the bank *d*, to *e*, taking with her a rope *b, c*, by which she is hauled back from *e*, to the bank *d*.

On the other hand, a flying bridge will not act well in a river with a very slow current at the sides, unless jetties or bridges of boats are built out from the banks, some distance into the river, for the flying bridge to come up to, for when the current at the sides is slight, it will not carry the boat close up to the shore.

A flying bridge was established a few years ago across the *Kistna*, in India: the breadth at the part where the bridge was made is between 700 and 800 yards in the rainy season, when the river is full, and the stream then runs in the middle of the river, at about four to four and a half miles per hour. The bed of the river is deep, but the sides shelve up. In the rainy season, when the river was quite full, the flying bridge acted very tolerably; but when the waters were out, the strength of the current at the sides, owing to the extreme shallowness of the water, was insufficient, and the flying boat could not be made to come up to the banks within about 40 yards.

When a river is too wide for a simple flying bridge, two boats may be used, one moving in an arc *c, d*, fig. 3, about the centre *a*, and the other in an arc *e, f*, about *b*, and a boat or a raft moored in the middle of the river, for shifting the passengers from one boat to the other. Or the raft may be dispensed with, and the cables shifted when the boats come close up to each other; the boat *d*,

being then made fast to the cable *b, e*, and the boat *e*, to the cable *a, d*, so that each boat will go across in two stages from one bank to the other, through *c, d*, and *e, f*.

Sir H. Douglas recommends this plan, in preference to having a raft in the middle (see Douglas on Military Bridges p. 96); we apprehend it might be attended with more danger of the boats fouling and doing injury if the current were very rapid, for both boats would be moving at their greatest speed, just where they would meet, viz. in the middle of the river; and hence the shock, if by accident they were to strike each other, would be twice as great as the shock of one boat against a stationary raft. Also the difficulty of managing them in a rapid current to change the cables, would be considerable, and the operation tedious.

We are not aware whether this plan has been extensively adopted in practice. The other is adopted in effect, and answers very well in the Nymuegen flying bridge; for though it has not two boats, the flying boat comes up to the end of the stationary bridge of boats, nearly in the strongest part of the stream.

In flying bridges the cable should be of a good length, for when it is long, the flying boat moving through the arc of a large circle, has to ascend the stream less than when the cable is short; that is, its direction is nearer to a strait line across the stream; and, consequently, less of the effective force of the current to impel the boat across, is abstracted by the resistance of the current to the ascent of the boat. For instance, in figure 1, with the cable *c, a*, the boat moves upwards, equal to a distance *a, l*; but if the cable were only as long as *c, l*, the boat in crossing, would move through a distance *l, n*, against the stream, which is much greater than *a, l*. ●

The whole motion of the flying boat from side to side, should not exceed a right angle, and then the angle *a, c, s*,

fig. 1, will not exceed 45° ; for when the angle a, c, s , exceeds 45° , the force c, l , that impels the boat sideways, in opposition to the current, becomes less than the force l, s , which holds it to the centre. This is shewn by the triangle c, n, m , fig. 1, where the angle n, c, m , is more than 45° . The force n, m , is greater than the force c, n , and the boat would not, in fact rise by the oblique action of the stream so far as m .

In narrow rivers, not exceeding two hundred yards in width, and with a tolerably rapid current, a flying bridge may be applied with effect, in the following manner:—

Let a cable be stretched across the river from bank to bank, and attached on each side to a frame secured in the bank, and drawn tight by a windlass; then attach the flying bridge to this cable, by means of a short rope, with a running block on the cable; and by keeping the boat in an oblique direction to the course of the stream, it will be carried across by the force of the current with considerable effect and expedition. This mode of establishing a flying bridge is more easy of adoption than the former one, and is attended with far less expense and trouble, as the buoys for the support of the cable may be dispensed with, and also the anchor for mooring it in the river.

This plan was used, to establish a communication across the Thames at Gravesend, during the threat of invasion from France. The cable was suffered to sink to the bottom, not to interrupt the navigation; and as the boat crossed, the rope rose to the point of suspension on the bank.

The cable should not be sunk when it can be avoided, because the boat has then to move the weight of the rope that connects it to the cable; and, moreover, the running block will run with a great deal more friction upon the wet cable than when it is out of the water.

A triangular raft may be floated over a river, as well

as a boat, if it be connected to a warp, or to a moored cable, in any of the ways we have described, by keeping one of its sides oblique to the direction of the stream.

Another mode has been found to answer well, viz. anchor the cable in the middle of the stream, and pass it over a pier of wood or masonry, built in the river, to the flying bridge on the opposite side of the pier. The bridge is then carried across the stream, if kept oblique to it, by the force of the current acting against its side, without the necessity of using buoys or boats for supporting the cable, which at all times tend greatly to impede the motion of the bridge, because the current acts upon them in an opposite direction to that in which it affects the flying bridge itself, and the latter has therefore in effect to drag the buoys through the water, against a considerable resistance.

When a river exceeds two hundred yards in width, it is necessary to adopt the mode of mooring the end of the cable in the stream, and passing it over buoys, or a pier to support its weight; but where a river is less than two hundred yards wide, the system of causing the flying bridge to traverse the river on a cable stretched across it from bank to bank, may be considered as far preferable in every respect. P.

NOVEL COOKING APPARATUS.

To the Editor of the London Journal of Arts, &c.

SIR,—A cooking apparatus in my kitchen, upon a novel construction, has given so much satisfaction on the score of convenience, economy, and good effect, that I am induced to forward a sketch of the contrivance for your insertion in the *London Journal of Arts*, if you should consider it worth a place among other projects of the day.

Upon a hot hearth, which is preferred to an open fire, is placed the tin vessel that the victuals are to be cooked

in. Plate XV, fig. 1, is a vertical section of this vessel; fig. 2, is a plan or horizontal representation of the same; *a, a*, is the hot hearth; *b, b*, the cooking vessel, which is made of tin plate, without cock or valves. In the centre is the part *c*, in which the joint of meat is steamed, and it is found most convenient to lower it into the vessel upon a fish tray; *e, e, e*, are narrow compartments filled with water, which surround the vessel *c*, on the sides and bottom, and there are passages of communication from these into the wing compartments *f, f*, also filled with water. The steam escapes* from *e, e*, through small openings at *g, g*, about one inch wide and two long, and so fills the central part *c*, the whole being closed tightly by covers.

When this apparatus is placed upon the hot hearth, the heat communicates to the boiler by the contact of the bottom, the wings not touching it by about an inch. The vessel will cook, that is steam, from 10 to 20lb. of beef, mutton, fish, or poultry, in a very superior manner to any cooking apparatus that I have before seen; the vegetables which cannot be steamed, without becoming tough and ill coloured, are boiled in the wing vessels *f, f*.

I consider it a great advantage in this vessel, that it will never boil over, or render the meat hard by cooking it too rapidly; it is easily kept clean both within and without, and for making soups, stews, or even coffee, is the best contrivance I have met with. In boiling eggs also in this apparatus, the sulphuretted hydrogen will be disengaged, which is a very desirable object to be effected, it being injurious to delicate stomachs; the eggs must be held in a suitable receptacle and lowered into the vessel in a raw state.

I am, Sir, your's, &c.

I. O.

**METEOROLOGICAL OBSERVATIONS IN DIFFERENT PARTS
OF THE KINGDOM, DURING THE YEAR 1831.**

To the Editor of the London Journal of Arts, &c.

SIR,—I send you the following account of Meteorological Observations, taken in different parts of the kingdom, which will I trust be interesting as a matter of comparison to many of your readers: the mode of keeping these registers was as follows:—

At Edmonton, the warmth of the day is observed by means of a thermometer exposed to the North in the shade, standing about four feet above the surface of the ground; the extreme cold of the night is ascertained by a self-registering thermometer in a similar situation; the daily range of the barometer is known from observations made at intervals of four hours each, from eight in the morning till eight in the evening; the weather and direction of the wind are the result of the most frequent observations; the rain is measured every morning at eight o'clock.

At Wycombe, the thermometer and barometer are registered at 8 A. M., at 3 and 10, P. M.; the extreme cold is ascertained by a self-registering thermometer. The wind is set down from the result of the most frequent observations.

At Cheltenham, the temperature is ascertained by a self-registering thermometer, suspended about five feet from the ground, in a North-east aspect, and the observation made daily about 8 o'clock, A. M. The winds and barometer are registered at 8 o'clock, A. M., and 8 o'clock, P. M.

CHARLES HENRY ADAMS.

GENERAL METEOROLOGICAL REPORT, FOR THE YEAR 1831.

KEPT AT EDMONTON.

MONTH.	Thermometer.				Barometer.				Rain.	WINDS.							
	Highest.	Lowest.	Mean.	Range.	Highest.	Lowest.	Mean.	Range.	In Inches.	N.	S.	E.	W.	N.E.	S.E.	N.W.	S.W.
January.....	50	16	31,9	34	30,5	29,14	29,45	1,36	1,27	3 $\frac{1}{4}$	—	3	—	9	7 $\frac{1}{2}$	3 $\frac{1}{2}$	4 $\frac{1}{2}$
February.....	62	10	41,22	52	30,3	29,	29,78	1,3	2,95	—	—	3	—	1	4	12	10 $\frac{1}{2}$
March	61	25	43,89	36	30,32	29,12	29,79	1,2	1,65	—	1	—	1	5	5	6	13
April.....	65	27	52,1	38	30,8	29,2	29,63	1,1	1,82	1	2 $\frac{1}{2}$	2	—	9 $\frac{1}{2}$	4	8	3 $\frac{1}{2}$
May	77	20	56,46	57	30,24	29,32	29,88	,92	1,65	1	1	3	1	14	4	3	4 $\frac{1}{2}$
June.....	77	37	60,12	40	30,17	29,56	29,78	,61	1,50	1 $\frac{1}{4}$	—	—	1	2 $\frac{1}{2}$	—	10	16
July	82	45	63,56	37	30,26	29,59	29,98	,67	2,62	—	1	2 $\frac{1}{2}$	1	8	3 $\frac{1}{2}$	5	11
August.....	79	48	64,48	36	30,21	29,64	29,94	,57	1,5	—	—	—	2	7	1	13 $\frac{1}{2}$	7
September.....	71	37	52,28	34	30,16	29,34	29,89	,62	3,67	1 $\frac{1}{2}$	—	—	—	1	6	11 $\frac{1}{2}$	10
October.....	69	38	54,35	36	30,38	29,29	29,82	1,04	4,4	—	—	—	—	1	8 $\frac{1}{2}$	1	20 $\frac{1}{2}$
November.....	58	28	42,22	36	30,44	29,26	29,82	1,18	1,6	—	—	—	—	2 $\frac{1}{2}$	1	9	17 $\frac{1}{2}$
December	55	21	41,67	34	30,39	28,9	29,79	1,49	2,15	—	—	—	—	1	2 $\frac{1}{2}$	10	17 $\frac{1}{2}$
Year	82	10	5,36	72	30,5	28,9	29,79	1,60	26,80	8	6	11	4	61 $\frac{1}{2}$	46 $\frac{1}{2}$	92 $\frac{1}{2}$	135 $\frac{1}{2}$

Lat. 51° 37' N. Long. 0° 8' W.W.

GENERAL METEOROLOGICAL REPORT, FOR THE YEAR 1831,

KEPT AT CHELTENHAM, BY MR. MOSS.

MONTH.	Thermometer.				Barometer.				WINDS.							
	Highest.	Lowest.	Mean.	Range.	Highest.	Lowest.	Mean.	Range.	N.	S.	E.	W.	N.E.	S.E.	N.W.	S.W.
January.....	50	25	36,47	25	30,26	28,91	29,64	1,35	5	1½	3½	1	5	14	½	½
February	61	29	42,7	32	30,07	28,75	29,56	1,32	3	5	—	4	1	1½	2½	11
March	60,5	32,5	46,52	28	30,16	28,9	29,57	1,26	—	4½	2	7	3½	3½	1	9½
April	62,5	34,5	49,63	28	30,14	28,86	29,44	1,28	6½	5½	5½	1	6	3½	—	2
May	69,5	33	54,14	36,5	30,18	29,22	29,81	,96	1	2½	11	2	6	4	½	4
June	72,5	48	61,3	24,5	29,97	29,44	29,78	,53	3	4	2½	5½	—	—	4	11
July	77,5	50	63,35	27,5	30,06	29,46	29,76	,6	8	2	1½	3	2	5	3	11½
August	77,5	52,5	64,47	25	29,96	29,44	29,71	,52	5½	8½	2	9	2½	2	3½	3
September.....	68	46	58,08	22	29,94	29,14	29,64	,8	9½	5½	1	1½	—	4½	—	8
October	68	48	57,33	25	30,06	29,02	29,56	1,04	—	11½	—	—	—	3½	—	16
November.....	58	32,5	46,37	25,5	30,24	29,16	29,65	1,06	—	—	½	6	½	4	4	15
December.....	58,5	35	46,08	23,5	30,2	28,52	29,53	1,68	—	9	3	3½	½	3	2	10
Year.....	77,5	25	52,20	52,5	30,26	28,52	29,6	1,74	36½	54½	32½	43½	27	48½	21	101½

Lat. 51. 50' N. Long. 2. 3' W.

GENERAL METEOROLOGICAL REPORT FOR THE YEAR 1831,

* KEPT AT HIGH WYCOMB, BUCKS, BY A MEMBER OF THE LONDON METEOROLOGICAL SOCIETY.

MONTH.	Thermometer.				Barometer.			Rain. In Inches.	WINDS.								
	Highest.	Lowest.	Mean.	Range.	Highest.	Lowest.	Mean.		Range.	N.	S.	E.	W. N.E.	S.E.	N. W.	S. W.	
January.....	49	19	33,01	30	30,34	28,61	29,57	1,53	2,72	6	1	6	4	4	6	1	
February.....	60,5	9	38,66	51,5	30,03	28,68	29,58	1,85	3,86	—	3	1	4	4	3	4	
March.....	60,5	27	42,64	33,5	30,23	28,88	29,61	1,35	2,88	2	1	—	6	3	2	7	
April.....	64,5	28	46,36	36,5	30,2	28,93	29,45	1,27	1,27	7	2	2	4	6	4	3	
May.....	69,25	25	49,72	44,25	30,06	29,17	29,65	,89	2,59	5	3	1	10	1	9	1	
June.....	73,75	39	55,59	34,75	29,95	29,32	29,70	,63	1,75	2	—	1	7	—	10	10	
July.....	78,5	4,25	58,77	36	30,09	29,36	29,72	,73	3,46	8	—	3	5	2	4	9	
August.....	75	43,25	60,50	31,75	30,02	29,39	29,70	,63	2,13	5	—	1	5	3	1	8	
September.....	68	36	53,78	32	30	29,07	29,66	,93	4,15	3	—	3	—	1	6	11	
October.....	69	30	51,91	39	30,15	29,02	29,60	1,13	3,63	1	4	1	1	1	9	14	
November.....	56	20,5	39,36	35,5	30,26	29,02	29,63	1,24	2,70	2	3	2	9	1	—	8	
December.....	52,5	22,5	38,90	30	30,19	28,66	29,46	1,53	3,46	1	3	—	4	3	4	7	
YEAR.....	7,85	9	47,43	69,5	30,34	28,66	29,33	1,68	3460	42	20	21	56	39	42	65	30

Lat. 51. 34' N. Long. 0. 47' W.

Recent Patents.

To HENRY DUXBURY, of Pomeroy Street, Kent Road, in the county of Surrey, gentleman, for his having invented a new machine for splitting hides and skins.
[Sealed 9th October, 1828.]

THIS machine is intended to divide the skins or hides of animals into two thicknesses, each of which may be afterwards separately worked, that is, tanned or dressed, for the purpose of making them into distinct skins of leather or parchment.

The skin intended to be split, is in its raw state, first extended with the flesh side upwards upon the periphery of a wooden roller, and there stretched out tight and smooth, fastening its edges by pins, hooks, or tacks, set round the roller, and by wedges or rods, let into grooves cut in the roller, in the direction of its axis.

The form of the roller is not perfectly cylindrical, but is made concave or hollow in the middle, in order to accommodate itself more correctly to the shape of the skin, and also to fit the edge of the circular cutter which turns round nearly in contact with the roller, as it splits the skin into two thicknesses.

Plate XIV. fig. 4, is a front elevation of the cutting machine; fig. 5, is a side view of the same; *a*, is the roller, on the periphery of which the skin is to be extended; *b*, is the circular cutter, mounted upon an axle, turning on the standards *c, c*, which cutter is driven by a band from any first mover passed round the rigger *d*, or by a winch or crank affixed to the axle; fig. 6, is a dia-

gram, shewing in section the roller *a*, with the skin stretched upon it, and the edge of the circular cutter *b*, splitting or separating the skin into two thicknesses.

The circular cutter *b*, being made to revolve, as shewn, a strap from the pulley *e*, upon the axle of *b*, drives a pulley *f*, below, on the shaft of which pulley there is an endless screw *g*, taking into the teeth of a wheel *h*, fixed on the shaft or axle of the roller *a*. Hence it will be seen, that when the circular cutter is made to revolve, the roller *a*, will be slowly turned, which causes the skin to be progressively brought forward to the cutting edge, and thereby split into two thicknesses.

In order that the skin may be conducted smoothly and evenly to the cutter, a guide piece *i, i*, is mounted in the frame *c, c*, the edge of which fits the form of the roller, and presses upon the skin, as seen in the diagram. That part of the skin which is uppermost, viz, the flesh side, is split away from that which is fastened to the roller, and turning upwards, passes through a slit or long opening *j*, in the guide piece, when it is rolled upon the roller *k*, in a sheet, as it is delivered from the cutter.

For the purpose of accommodating the machine to skins of different thicknesses, the guide piece *i, i*, is made to rise and fall in grooves in the standards, which adjustment is effected by drawing up the chains or rods *l, l*. The rotation of the roller *a*, may be instantly stopped, if the cutting appears to be irregular, by sliding on one side the clutch box *m*, which connects the roller *a*, and the toothed wheel *h*, together.

For operating upon small skins, it is in the contemplation of the Patentee, to adapt two rollers, each carrying a skin to one rotary cutter, as shewn in the diagram fig. 7; and to suit skins which are of unequal thicknesses, the guide *i*, may be made with many falling pieces, as shewn

at fig. 8, which pieces will severally rise and fall, according to the thickness of the skin under operation.—
 [Inrolled in the Inrolment Office, April, 1829.]

To WILLIAM MORGAN, of York Terrace, Regent's Park, in the county of Middlesex, Esq. for his having invented certain improvements in steam-engines.
 [Sealed 14th February, 1831.]

THESE improvements are intended to be adapted to those kinds of steam-engines which act upon the rotary principle, having a reciprocating leaf and axles, as that described in the Specification of a Patent, granted to Elisha Galloway, July, 1829, described in the Sixth Vol. of our Second Series, page 193, of which the present Patentee states that he is now the proprietor by purchase.

The improvements proposed, consist in several arrangements of levers and pulleys, constituting modes of converting the reciprocating action of a piston, which pass to and fro through one half a rotation into a rotary power, that is, of giving rotary motion to the axle of a fly wheel, or a propelling wheel, from the vibrations of the reciprocating piston, or leaf and axle of the engine.

Plate XV, fig. 9, shews the first plan proposed; *a*, is a pulley or drum, affixed to the reciprocating shaft of the engine; *b*, is the crank of the axle, which is to be driven round. A chain *c*, is fastened at one end to the periphery of the pulley, and at the other end to a vibrating lever *d*, and a simliar chain *e*, is fastened in like manner to the pulley, and to the lever at opposite points.

When the pulley *a*, by the vibratory action of the engine, turns in the direction of the arrow, the lever *d*,

and the crank, will be brought into the position shewn by dots. When the pulley turns in the reverse direction, the lever and crank will be brought to the opposite part of the dotted circle, and the fly wheel, or propelling wheel, fixed on the crank shaft, will, by its momentum, carry the crank past the dead points, and so by the vibration of the engine at *a*, the shaft *b*, will be made to continue revolving.

Instead of the chains described, the lever *d*, may have a rack formed upon its edge, taking into a toothed segment on the edge of the pulley, which, as the pulley vibrates, will move the lever to and fro, and effect the same object as the chain.

Fig. 10, shews the second plan of converting a reciprocating into a rotary motion; *a*, the axle of the reciprocating engine; *b*, that of the fly wheel, or propelling wheel, which is to be made to revolve; *c*, is a beam or lever, vibrating on a fulcrum pin in its centre. From the axle *a*, a crank *d*, extends, which is connected to the lever by a pin, working in a slot *e*, near the extremity; the reverse end of the lever is by a link *f*, connected to the crank *g*. It will hence be seen, that as the axle of the engine *a*, reciprocates, the crank arm of the shaft *b*, will be driven round, and rotary motion be thereby communicated to the shaft.

Fig. 11. is a variation of the last described contrivance, in which, instead of the crank arm *d*, a plate *i, i*, is affixed to the end of the axle of the vibrating engine, having a long groove *k, k*, in which a boss at the end of the beam *c*, acts, and by sliding up and down in this groove, as the plate reciprocates, gives that vibratory action to the beam, which in the preceding instance was effected by the crank arm *d*.

The fourth plan is a combination of levers, shewn at

fig. 12; *a*, is the reciprocating axle of the piston of the engine; *b*, the crank shaft to be driven; *c*, an auxiliary arm, moveable upon a fixed pivot, at the end of which arm the fulcrum of the small lever *d*, is placed. As the crank arm of the axle *a*, vibrates, these levers move into different positions, and by means of the link *e*, drive round the arm and axle *b*.

The fifth contrivance consists in attaching the crank of the shaft, intended to revolve, to a sliding carriage, which is made to reciprocate by its connection to the axle of the engine. This is shewn at fig. 13, in which *a*, is a pulley, fixed on the reciprocating axle of the engine, to which pulley the ends of two chains are attached, in the manner described in the first plan; the reverse ends of these chains are made fast to a sliding carriage *c, c*, which runs upon rollers or wheels *d, d*, in the guide frame *e, e, e*; to the axle of one of these wheels, or to the sliding carriage, one end of the link *f*, is attached, and the other end of the link is connected to the crank arm of the shaft *b*. As the piston or leaf of the engine reciprocates, the carriage *c*, is driven to and fro, by which means the link *f*, causes the shaft *b*, to revolve.

There is no alteration proposed in the construction of the internal or operative parts of the engine itself, the contrivances above described constituting the subject matter of the invention, which it is said may be adapted to any engine on the reciprocating rotary principle, whose piston does not pass through more than an arc of about half a rotation.—[Inrolled in the Inrolment Office, August, 1831.]

To JAMES VINEY, of Piccadilly, in the county of Middlesex, Colonel in the Royal Artillery, for his having invented certain improvements in steam boilers, used in carriages, or apparatus connected therewith.—

[Sealed 2d November, 1829.]

THE Patentee states that the first part of his invention consists in certain improvements in steam boilers, viz. in making such boilers of a conical shape, and with circular conical flues; whereby he is enabled to apply the heat of lamps, fed with oil or gas, as effectually as other fuel; which enables him to expose a much more extended surface of fuel, in a given space of boiler, than by any method now in use. The second part of this invention applies to steam carriages connected with the said boilers, in which it is proposed to dispense with the water tank, separator, blowing box, and the apparatus connected therewith, as now in general use for steam carriages.

In Plate XV. fig. 3, is a horizontal representation of a steam boiler on the proposed plan, consisting of eight steam generators *a, a, a, &c.*; each of which, if made on a large scale, might be considered as a separate steam boiler; but one great advantage of this invention, is the diminutive size of these generators, compared with the extent of heated surface they expose to the water, and which, the Patentee says, enables him to place them in a great variety of positions, to suit the form of engine required. Eight vessels are here described as the number constituting a boiler, and it is only necessary further to observe, as regards this figure, that the top or chimney is supposed to be removed, which would otherwise conceal the position of the generators, for such the Patentee calls each of the small circular boilers shewn in this figure.

Fig. 4, is a vertical section of one of the said generators, drawn on a larger scale for the purpose of better elucidation. Fig. 5, is a horizontal section of the same at bottom; and fig. 6, at top; fig. 7, being an external elevation of the generator, which is cased in with wooden staves and hooped as a barrel; the sides of the generator, it will be observed, are conical, being larger at the top than at the bottom, as *b, b, b, &c.* The parts marked *c, c,* are circular conical flues; and *d,* is a lamp to heat the water in the boiler; the parts marked *e,* are communication pipes, for the steam to pass through, and the parts marked *f,* are similar pipes for the water; *g,* is the top or chimney to receive the smoke (if any,) from the flues; *h,* is the steam pipe, and *i,* is a waste steam pipe, which conducts the waste steam under a semicircular pipe or gutter, placed over the top of the first compartment, or space between the side of the boiler and the first flue. This gutter is pierced with holes in its upper surface, to admit the waste steam to escape without, the noise that usually accompanies it. It is only necessary to add, that each generator is furnished with safety valves in the ordinary way, and when several are used, as in fig. 3, communication pipes must be added, to connect them in their operation.

The specification concludes in these words, "Now whereas, it is evident that one of these generators made on a large scale, and adapted to be heated by a furnace in the ordinary way, would serve of itself for a boiler, but I prefer a combination of small ones, as shewn in fig. 3, as better adapted to suit the convenience of such irregularly formed boilers, as may be required for particular purposes. And whereas, I claim as my invention, first (as regards my said improvements in steam boilers), the generators with conical sides, and circular formed

flues, herein before described, either combined in any number or in any suitable position, as shewn in fig. or any one of them made on a larger scale as aforesaid, and thus forming one complete boiler of itself. And further (as regards my said improvements in steam carriages, or apparatus connected therewith) I claim the doing away of the tank, seperator, blowing box, and apparatus connected therewith."—[*Inrolled in the Inrolment Office, May, 1830.*]

To ANDREW URE, of Burton Crescent, in the county of Middlesex, doctor of medicine, for his having invented an apparatus for regulating temperature in vaporization, distillation, and other processes.—
[Sealed 20th October, 1830.]

THIS invention is founded upon the principle of the compensation balances applied to chronometers, which are constructed of two or more long slips, or thin bars of different kinds of metal, connected together by rivets or solder; the several metals having different expansive properties under similar temperatures, and, consequently, by expanding when in connection, bend or warp the compound bar out of its original form or figure. The apparatus is called a Thermostat.

The principle admits of being variously modified in its construction, and may be applied in many different situations, where a varying temperature can act upon it, for the purpose of becoming a self-moving agent. The intention of the Patentee is to adapt this contrivance to distilling apparatus particularly, in order that by its expansion or contraction, it may open or close a water cock, and thereby admit such a regulated current of the cooling fluid, as shall at all times keep the materials under operation at a uniform temperature. The same

contrivances are also applicable to regulating temperature in stoves and heating apparatus of various kinds.

The construction of the proposed apparatus admits of almost as many varieties as its adaptation; the Patentee has exhibited several, merely as illustrations. Plate XV. fig. 8, shews one mode of applying the contrivance; *a*, is a bar, composed of two thicknesses of metal, brass and steel united, and made fast at the end *b*, to the place where it is to be used, which may be called its fulcrum. At the reverse end *c*, a link connects the bar to a lever *d*, which by the rod *e*, raises and depresses a sliding door or damper *f*.

When heat is applied to the compound bar *a*, it elongates, and that metal, which expands most under a given temperature, being uppermost, causes the bar to bend down, as shewn by dots, and by that means to raise the door. If placed within a boiler, the same might open a cock or valve, and on the temperature being lowered, it would rise and close the cock or valve.

Fig. 9, is another modification of the contrivance, consisting of several pairs of compound metallic bows *a, a, a*, connected together, the lower one of which is fixed by an adjustable screw to the bottom of the box *b*, and the upper one to a sliding rod *c*. The outer parts of these bows being composed of metallic bars, which are more readily susceptible of expansion by heat than the inner parts. On the temperature of the surrounding medium becoming increased, the bows rise upon the central pin *d*, and in so doing lift the rod *c*, which having a rack *e*, at its end, turns the circular piece *f*, upon its centre, and thereby opens a ventilator, or turns any other apparatus, by which a cool current may be admitted. When the temperature of the surrounding medium becomes lowered, of course the bows flatten, and come closer together, drawing down the rod *e*, and closing the ventilator.

Fig. 10, shews the Thermostat in a circular form, that is, a hoop *a, a*, constructed by uniting two thin slips of dissimilar metals. At the open parts of the hoop two levers *e, c*, are attached by joints, and which levers are connected together and to a sliding rod *d*, at the joint *e*.

If this hoop *a, a*, be fixed at the part *f*, in a vessel, the varying temperatures of which are required to be known, the different degrees of heat will cause the hoop to expand and contract, and in so doing, to move the arm *g*, upon its fulcrum *h*, which will cause the cock *h*, to open or close the water way of the pipe *i*, leading from a cistern *k*, and by that means to increase or diminish the flow of the cold water from the cistern, according as the heat of the fluid in which the Thermostat is immersed may require it. There is a graduated arc *l*, proposed as a thermometrical scale, to exhibit the temperature which is pointed out by the end of the arm *g*.

Fig. 11, is another modification of the contrivance, designed to be placed within a chimney or flue, for the purpose of opening a damper when the heat becomes too great; *a*, and *b*, are each a compound bar, composed of two dissimilar metals. These bars are fixed in pendant positions at their upper parts, to a stationary bar in the chimney; and when the heat of the flue causes the compound bars to expand, they will so move the levers at *c*, as to open the damper and admit a current of air to cool the parts within. This arrangement is called a Pyrostat

It must be repeated, that these are only illustrations of several constructions and modes of adapting the principle, but the Patentee claims generally the adaptation of combined bars of metal, whose properties render their opposite surfaces susceptible of different degrees of expansibility, under any given temperature, for the purpose of moving levers, or otherwise operating to open or close valves,

cocks, or registers, for regulating the temperatures of fluids, or airs for, refrigerating or ventilating.—[*Inrolled in the Inrolment Office, April, 1831.*]

To ANDREW URE, of Finsbury Circus, in the county of Middlesex, M. D. for his having invented an improved apparatus for distilling.—[Sealed 31st March, 1831.]

THE object of this improved apparatus for distilling, is that the wine wash, or other fermented liquor, during its passage into the alembic or kettle, shall be most extensively exposed to the hot vapour ascending and descending from the said kettle, in a very thin stream or stratum, on a series of shelves, trays, gutters, or channels, placed over each other. By this exposure to the cool wash, the temperature of the vapour is partly moderated towards the degree most favourable for the production of a fine spirit, and the wash itself is partly stripped of its finer alcoholic particles, by a steam distillation, before it reaches the alembic.

The physical principles on which the apparatus is intended to act, may be stated as follows:—Fermented liquor contains three ingredients, all volatile by heat, but at different successive degrees of temperature; alcohol, essential oil, and water. If a mixture of these three substances in the vaporous state, be passed upwards through tortuous tubes or channels, maintained by any means at a temperature under 160° Fahrenheit, alcoholic vapour alone, in any considerable quantity, will retain its tension or continue to exist, so as to pass onwards into the refrigerator; if the said channels acquire a temperature of 180° Fahrenheit, some essential oil, and steam will accom-

pany the alcohol vapour, and pass onwards with it; and if the channels acquire the temperature of 212° Fahrenheit, the said three volatile matters, will all pass freely into the condenser, so as to constitute a spirituous liquor, more or less crude according to the crudity of the fermented matter.

Now, it is proposed by this exposure of the cool wine, or wash, on an ample series of surface, in the progress of its descent into the alembic, to refrigerate the mixed vapours as much as possible, both by the heating and evaporating of the wine or wash, and to supply whatever additional refrigeration may be desired by the application of water, at a regulated temperature, to the metallic vessel or cases, which contain the said series of shelves, trays, gutters, or channels.

Figs. 12 and 13, represent in section two forms of the moveable frame, or system of moveable shelves, trays, or channels, which constitute a leading feature of the improved apparatus for distilling. The vessel of fig. 12, is cylindrical; that of fig. 13, is rectangular.

In fig. 12, *a, a*, represents the section of an exterior cylindrical annular space, contained between two metallic cylinders; and *b, b*, represents the section of an interior cylindrical annular space; each of these spaces is furnished with a series of annular shelves, trays, or channels, standing over one another, at a distance of one inch or more; each of which is perforated with a slit or holes at one part, for the descent of the thin stream or wash, into the subjacent shelf. Across the upper surface of each annular shelf or tray, a vertical ridge is fixed to one side of the slit or holes, so that the liquor being delivered always on the side of the ridge opposite to the said slit or holes, must perform a complete revolution on the shelf, before it can descend into the next shelf, and so on in succession.

These annular shelves have their edges turned up, as shewn in the section which prevents the liquor from escaping over the edges, while it stiffens the flat metallic ring.

The system of shelves for one annular cylindric space, may be conveniently connected by three or four rods passing down them, so as to bolt or solder them together, and permit them to be drawn up easily in one body, for the purpose of cleaning or adjusting at any time.

The fermented liquor is admitted in a regulated stream, into the top shelves through the stop cock *c*, of which the key may be mounted with a graduated arch; or the pipe between the top cock and the ball *d*, may be a graduated glass tube, the height of the liquid column in which will determine the rate of efflux through the two orifices below, which are of different widths, but together much smaller in area than the water-way of the above stop cock.

The top of each cylindrical annular space is covered in by an annular plate, which is secured with bolts and packing, in the usual way. The bottom of each annular space is closed either by a special annular plate, or by a circular plate, including both spaces. The pipe *e*, represents the back of the alembic, which rising with a gentle slope, enters the bottom of each of the cylindric annular spaces, at *f*, *f*, whence it diffuses the vapours freely all around and upward, among the moveable system of annular shelves.

The rectifying cylinder, fig. 12, and its shelves, may be advantageously made of tinned copper, or of lamine of tin, hardened with a copper alloy; but it is desirable to pass the spirituous vapour at last up through one spiral coil of tin plate, as shewn at *g*, *g*; immediately before its entrance into the refrigatory worm in *h*. The tub or back *h*, is filled with water, which bathes the outside

of the rectifying cylinder, as well as the interstices between the concentric cylinders. As this water tends in the progress of distillation to become too hot, especially when a strong alcohol is sought for, its temperature is regulated by the application of a Thermostat, or heat governor, fig. 14, described under several modifications in the specification of a patent for that invention granted to the same Patentee. (See the preceding patent.)

The links *a, a*, connected with the expanding ends of the thermostatic bars *b, b*, act on the stop cock *c*, of a cold water cistern, so that whenever the temperature of the surface water of the bath, in which the said bars are plunged, exceeds the defined degree, a stream of cold water is admitted into the body of the bath through the pipe *d, d*, so as to chill it, and cause the hot water to pass off through the overflow pipe *e*. The screw nut *f*, serves to adjust the length of the rod *g*, so that the stop cock may be opened more or less, at any desired point in the thermostatic bars.

Fig. 13, represents, in a rectangular form, a similar moveable series of shelves or trays, for the extensive exposure of a stream of wine or wash, to the boiling hot vapours, in its descent into the alembic; *a, a, a*, are rectangular cases or hollow parallelopipedons, of which the width is small compared with the length and height. These cases are open at top and bottom, where they are soldered or riveted into a general cavity, enclosed by covers, secured with packing and bolts in the usual way. Each case is furnished with a series of straight shelves or oblong trays, turned up at the edges, and at one end, but slightly sloped at the other for the discharge of the wine or wash into the subjacent shelf. The direction of the stream in each shelf is the reverse of that in the shelf above and below it, as seen in fig. 15; where

the turned up end of one shelf corresponds to the discharge slope of its neighbour. These shelves are framed together, by two or more vertical metallic rods, which pass down through them, and are fixed to each shelf by a screw nut, solder, or otherwise. Hence, when the cover is removed, each set of shelves may be readily lifted out of its compartment and cleaned.

The shelves may be laid in a horizontal position, or with a slight declining in the direction of the stream. The cellular intervals between the shelf cases allow a free circulation of the water contained in the external bath cistern *i, i*; the temperature of which is regulated by a heat governor *k*, connected with the stop cock or valve of a cold water back as above described. The wash descends through the main pipe *c*, into the horizontal pipe *h*, which has apertures to allow equal jets of distribution, corresponding to the series of oblong trays, or shelves, shewn in the section fig. 13, and in the plan fig. 16.

Fig. 15, is a side view of one shelf compartment, to shew the to and fro course, and descent of the current of wash in its passage to the alembic. The shelf case may be advantageously made three inches wide, for more ample exposure of the wash or wine, while the water cell is only one inch; for this body of water will easily control the temperature of that body of vapours.

In some cases of distillation the Patentee says, that he does not apply the naked heat of a fire to the bottom of the alembic, but immerses it in a bath of muriate of lime, contained in a suitable pan, and regulated by the thermostat mentioned before. In other cases he proposes to plant on the flat bottom of a round alembic, an upright metallic lamina, twelve inches more or less high, and of such a length that it may form a helix like the main spring

of a watch, extending with numerous coils from the centre to the circumference; or the alembic being rectangular or oblong or of any shape, the said metallic lamina or riband, may be planted upright in a zigzag direction, from one end of the alembic to the other. Whatever form this open winding channel may have, its object is the same, namely, to enable the wash already stripped in a great measure of its spirit, by the stream distillation on the rectifier vessel, figs. 12 and 13, to throw off the remainder of its alcohol, in its tortuous journey of ebullition over the bottom of the alembic.

A syphon pipe, furnished with a swivel stop cock, regulates the depth of liquor on the bottom of the still, and the level of discharge. Should any appreciable spirit be found in the discharged or spent wash, the rate of influx of fresh water into the shelf cases may be moderated.

When this continuous plan of distillation, by a perpetual ingress and egress of the wash, till the whole be worked off, is not adapted, it is recommended to the distiller to use the apparatus in the following way:—Let him introduce into the alembic, just enough of his fermented liquor to protect the copper from injury by the fire, reserving the main body of the said liquor in the charging back; as soon as the ebullition in the alembic, conducted with the usual precautions, has raised the temperature of the rectifying bath to the desired pitch, let him open the communications with the charging back, turning the index of the graduated stop cock, so as to admit the wash in a regulated stream. Towards the end of the operation, after all the wash has run into the still, he may, for the sake of dispatch, permit the rectifying bath to take a higher temperature, and draw off the cruder and weaker spirits into a separate cistern, from which

they may be pumped into the still, as the starting or preparatory liquor of a second charge.

For the rectifying of spirits, this distilling apparatus may be worked in the same way, that is, some weaker spirits being introduced into the still, to generate steam and heat the shelf apparatus, the relatively stronger spirits in the charging back, may then be admitted through the cock and pipe *c*, in a regulated stream, while the thermostatic apparatus is so adjusted as to maintain a proper temperature in the water bath rectifier.

This plan of water bath, combined with the thermostatic apparatus, may also be used simply as a rectifying cistern, without transmitting the spirit or wash through it, since the series of shelves will cause the vapours from the still to impinge against a most extensive system of metallic surfaces, maintained at a regulated temperature, whereby their waters and crude constituents will be condensed and precipitated, while their finer alcoholic particles will proceed forwards to the refrigeratory.

A similar system of compartments furnished with shelves, especially the construction shewn in fig. 13, being immersed in the refrigeratory tub or back *h*, will afford an eligibly substitute for the serpentine usually employed. For this purpose the cases *a, a, a*, are best made of laminated tin, hardened with a little copper alloy, and they should be narrower, compared to the water cells. The spirituous vapours must of course be admitted by the upper pipe *m*, and the liquid spirit drawn off from the pipe *l*. Such a cold condenser presents the great advantage of permitting its interior passages to be readily inspected and cleansed.

The Patentee says, lastly, " I claim as my invention, the aforesaid applications of a horizontal or inclined moveable system of shelves, trays, channels, or gutters, either

straight or curved, and enclosed in metallic cases separated by water, for the purpose of exposing on an ample surface, during their descent into the alembic, fermented, or alcoholic liquids, to the action of the hot vapour arising from that alembic; and I secondly claim the combination of this moveable system of shelf cases, with my thermostatic apparatus for regulating the temperature of the water bath in which these cases are immersed; and I thirdly claim the application of the moveable system of shelf compartments, to the purpose of a condensing refrigeratory, for converting the alcoholic vapours into cool liquid; and I finally claim the application of a muriate of lime bath, regulated by the thermostat to the heating of the alembic, whereby empyreuma in the distillation of wash from all grains, &c. may be entirely prevented." [Inrolled in the Inrolment Office, September, 1831.]

To WILLIAM MANN, Effra Road, Brixton, in the parish of Lambeth, and county of Surrey, gentleman, for his having discovered or found out that by the application of compressed air, power and motion can be communicated to fixed machinery, and to carriages, and other locomotive machines, and to ships, vessels, and other floating bodies.—[Sealed 1st June, 1829.]

FROM a perusal of the above curious title, it would appear that the Patentee had no knowledge of the application of compressed air in the air gun, or of its adaptation in a thousand other ways, to obtain mechanical power; but even if it had not been known before, his having merely discovered, or found out, that by the application of compressed air power and motion can be

communicated to fixed machinery, and to carriages, &c. &c. is not a discovery upon which a patent can be granted; because the discovery itself is not a vendable matter; whoever therefore has dictated the title of this patent, has omitted that which should have been the very essential part of it, (*viz.*) that he has invented or discovered a *mode of compressing, or of applying* compressed air, &c. We take this opportunity of pointing out the fatal effects of an erroneous title, convinced that in the present instance, we are not by the exposure, subjecting a new or useful invention to the jeopardy of legal consequence, and may perhaps be communicating a hint that will be found useful to future Patentees.

The specification, which is extremely long, commences by telling us, that, atmospheric air may be compressed in close iron or other vessels, by means of manual or animal labour, by wind mills, water mills, steam engines, and other means, and that when so compressed, the vessel containing the air may be conveyed from place to place, and may be stationed in any required situation: and the air may be let off from the vessel in small currents and allowed to expand, so as to communicate by its elasticity a mechanical power capable of actuating or impelling machinery.

The common mode of compressing air, is by forcing it into a strong vessel, by means of an air pump, by which a large volume of air, at the usual density of the atmosphere, is taken and compressed into a small compass within the close vessel: the pumping operation being continued until the air within has reached that degree of density or compression required.

This the Patentee proposes to do, by means of a series of air pumps connected together; the first pump com-

pressing the air perhaps ten times, and the second ten times, bringing the condensation to a hundred times that of the natural atmosphere, and so on to any degree of density that may be desired. It is observed that this will not reduce the whole amount of mechanical labour, requisite to bring the air to the same degree of condensation, by a single pump, but yet it is to be preferred.

There is to be a reservoir connected to each pump, to receive the air as it is forced in, and a valve to prevent its returning, from which reservoir the condensed volume is taken by the second pump, and still further compressed as we have said above. No drawings accompany the specification, illustrative of the Patentee's plans, but several elaborate tables are given, shewing the required dimensions of the pistons and chambers of the series of pumps, diminishing in arithmetical progression.

When suitable strong vessels have been thus charged with condensed air, the vessels may be conveyed to the situations in which they are to be employed for actuating or driving machines, and the compressed air being then let out from the vessel in small quantities into a receiver, is there allowed to expand to a certain volume or pressure, when it may be admitted into a working cylinder, for the purpose of raising or depressing a piston by its elastic force, in the same manner as steam is applied.

In this way it is proposed, that condensed air should be employed as a power, in preference to steam, for driving locomotive engines and carriages, propelling vessels on water, and working machinery in general. Vessels containing this condensed air, may be transported from place to place, like portable gas, for actuating lathes and other small machinery, where steam engines would be inconvenient; and the air, in its condensed state, may be conducted to any part of a manufactory by means of

pipes, in the same way that Mr. Hague^u works his cranes at St. Katharine's Docks. (See the first Vol. of our present Series, page 95.) It is further proposed to employ this power in fortifications for discharging ordinance, by conducting the condensed air through tubes from a reservoir to any part of the ramparts.

In order to obtain condensed air in large quantities, steam engines are to be employed to work the air pumps; or windmills, water-mills, and in many cases, the tread-mills of prisons may be made available for this purpose.

When the power is to be applied to locomotive carriages running from one town to another, steam engines should be erected, at not more than ten miles apart, to supply the vessels with condensed air, as they become exhausted; and in the event of a line of locomotive carriages being established between London and Newcastle on Tyne, the surplus coal may be usefully employed in the neighbourhood of the collieries for producing steam to generate a power for condensing the air, and the vessels may be conveyed to different stations on the road, ready to be taken up for use. (See the Specification of C. C. Bombas, for propelling, &c. Vol. II. of our present Series, page 278).

We presume that enough has been said in the above report to convey a tolerable notion of the scheme proposed by the Patentee. It is not necessary for us to say another word as to the originality of the idea suggested, or of the practicability of the project; its obvious absurdity and uselessness must be perfectly evident.—[*Inrolled in the Inrolment Office, December, 1829.*]

Steam Carriages.

THE Committee of the House of Commons, appointed to examine the practicability of employing steam carriages on ordinary roads, having issued their Report, we have much pleasure in presenting our readers with an extract of such parts, as appear to possess a character of importance, and to throw light upon this interesting subject.

“ The Committee proceeded in the first instance to inquire how far the Science of propelling Carriages on Common roads, by means of Steam or mechanical power, had been carried into practical operation ; and whether the result of the experiments already made had been sufficiently favorable to justify their recommending to The House, that protection should be extended to this mode of conveyance, should the Tolls imposed on Steam Carriages, by local Acts of Parliament, be found prohibitory or excessive.

“ In the progress of their inquiry, they have extended their examination to the following points on which the chief objections to this application of Steam have been found ; viz. the insecurity of Carriages so propelled, from the chance of explosion of the boiler, and the annoyance caused to travellers, on public roads, by the peculiar noise of the machinery, and by the escape of smoke and waste steam, which were supposed to be inseparable accompaniments.

“ It being also in charge to the Committee, ‘ to report upon the proportion of Tolls which should be imposed upon Steam carriages,’ they have examined several proprietors of those already in use, as to the effect produced

on the surface of roads by the action of the propelling wheels.

“ As this was too important a branch of their inquiry to rest entirely on the evidence of individuals, whose personal interest might have biassed their opinions, the Committee also examined several very scientific Engineers, by whose observations on the causes of the ordinary wear of roads they have been greatly assisted.

“ The Committee were directed also to report ‘ on the probable utility which the Public might derive from the use of Steam Carriages.’ On this point they have examined a Member of the Committee, well known for his intelligence and research on subjects connected with the interests of society, and they feel that they cannot fulfil this part of their instructions better than by merely referring The House to the Evidence of Colonel Torrens.*

* He says “ ‘ I conceive that agriculture is prosperous in proportion as the quantity of produce brought to market exceeds the quantity expended in bringing it there. If Steam Carriages be employed instead of Carriages drawn by horses, it will be because that mode of Conveyance is found the cheapest. Cheapening the carriage of the produce of the soil must necessarily diminish the quantity of produce expended in bringing a given quantity to market, and will therefore increase the net surplus, which net surplus constitutes the encouragement to agriculture. For example, if it requires the expenditure of two hundred quarters of corn to raise four hundred, and the expenditure of one hundred more on carriage, to bring the four hundred to market, then the net surplus will be one hundred.

“ ‘ If, by the substitution of Steam Carriages, you can bring the same quantity to market, with an expenditure of fifty quarters, then your net surplus is increased from one hundred to one hundred and fifty quarters; and consequently, either the farmer’s profit or the landlord’s rent increased in a corresponding propor-

“ These inquiries have led the Committee to believe that the substitution of inanimate for animal power, in

tion. There are many tracts of land which cannot be cultivated, because the quantity of produce expended in cultivation and in carriage exceeds the quantity which that expenditure would bring to market. But if you diminish the quantity expended in bringing a given quantity to market, then you may obtain a net surplus produced from such inferior soils, and consequently allow cultivation to be extended over tracts which could not otherwise be tilled.

“ ‘ On the same principle, lowering the expense of carriage, would enable you to apply additional quantities of labour and capital to all the soils already under cultivation. But it is not necessary to go into any illustrative examples to explain this, it being a well-known principle, that every improvement which allows us to cultivate land of a quality which could not previously be cultivated, also enables us to cultivate in a higher manner, lands already under tillage.

“ ‘ If Steam Carriages were very suddenly brought into use, and horses thereby displaced, I think the effect stated in the question would be produced for a time; but practically, Steam Carriages can be introduced only very gradually, and the beneficial effect upon the profits of trade, by bringing agricultural produce more cheaply to market, will tend to increase profits, to encourage industry, and to enlarge the demand for labour; so that, by this gradual process, there will probably be no period during which any land can actually be thrown out of cultivation, the increasing population requiring all the food which horses would cease to consume.

“ ‘ With respect to the demand for labour, that demand consists of the quantity of food and raw materials which can be cheaply obtained: and as, by the supposition, the displacing of horses will leave at liberty more food and more material, the demand for labour will ultimately be greatly increased instead of being diminished. It has been supposed, I know not how accurately, that there are employed on the common roads in Great Britain, one million of horses, and a horse, it is calculated,

draught on common roads, is one of the most important improvements in the means of internal communication

consumes the food of eight men. If Steam Carriages could ultimately be brought to such perfection as entirely to supersede draught horses on the common roads, there would be food and demand for eight million of persons. But when we take further into consideration, that lowering the expense of carriage would enable us to extend cultivation over soils which cannot now be profitably tilled, and would have the further effect of enabling us to apply, with a profit, additional portions of labour and capital to the soil already under tillage, I think it not unfair to conclude, that were elementary power on the common roads completely to supersede draught horses, the population, wealth and power of Great Britain would at least be doubled.

“ ‘ If there are soils of such a peculiar quality that oats is the only marketable product which they will yield, the persons employed in cultivating those lands would certainly be thrown out of that particular occupation; but the extension of tillage over other lands not of this peculiar quality would create a demand for labour which would much more than absorb the persons thrown out from the culture of oats upon that land which would grow nothing else. But I doubt of there being any land which it is profitable to cultivate, which would not raise some other agricultural produce than oats either for man or cattle, for which the increasing population would create a demand.

“ ‘ Upon the case supposed, namely, that Steam Carriages should be employed in conveying passengers only, and the whole change to be effected in a sudden manner, I think that there would in the first instance be a diminished demand for agricultural produce, but the following process would take place. As the demand for agricultural produce was diminished, the price of such produce would fall, food would become cheaper, and the cheapening of food would benefit partly the labouring class and partly the capitalists, the one obtaining higher real wages, and the other higher profits; this increase in real wages and in profits, would effect a great encouragement to manufacturing industry, and would necessarily lead to an increase in the manufacturing

ever introduced. Its practicability they consider to have been fully established; its general adoption will take

population, and to the amount of capital employed in manufactures. The consequence would be, that after some degree of pressure upon agriculture, the increased number of human beings would create the same demand for agricultural produce which the employment of horses formerly created.

“ ‘ So that even upon the extreme and most improbable supposition, that Steam Carriages should never be employed in conveying agricultural produce to market at a cheaper rate, still the benefit to the country would be very great, inasmuch as we should have a vastly increased industrious population, and England would become much more extensively, than she is at present, the great workshop of the world. In point of fact, superseding horses by mechanical power, would have precisely the same effect in increasing the population and wealth of England, as would be produced were we to increase the extent of the country by adding thereto a new and fertile territory, equal in extent to all the land which now breeds and feeds all the horses employed upon common roads. Such addition to the extent of fertile territory in England suddenly effected, would, in the first instance, lower the value of agricultural produce, and be injurious to the proprietors of the old portion of the territory, but no person would therefore contend that if we could enlarge the Island of Great Britain by additional tracts of fertile land, the public interests would be injured by such enlargement; this would be monstrously absurd. It is not less absurd to object to the increase of food available for human beings, by substituting mechanical power for horses.

“ ‘ On the principles that have been already stated with respect to agriculture, the cost of bringing all things to market is comprised of the cost of production and the cost of carriage. Reducing the cost of carriage is precisely the same thing in its effects as reducing the immediate costs of production, consequently the conveyance of light goods by Steam power, must cheapen all such goods to the consumers. This will necessarily enable them to consume a greater quantity of such goods, and the consumption of the greater quantity will enlarge the demand for labour, call a

place more or less rapidly, in proportion as the attention of scientific men shall be drawn by public encouragement to further improvement.

“ Tolls, to an amount which would utterly prohibit the introduction of Steam Carriages, have been imposed on some roads ; on others, the Trustees have adopted modes of apportioning the charge, which would be found, if not absolutely prohibitory, at least to place such Carriages in a very unfair position as compared with ordinary coaches.

“ Two causes may be assigned for the imposition of such excessive Tolls upon Steam Carriages. The first, a determination on the part of the Trustees, to obstruct, as much as possible, the use of Steam as a propelling power ; the second, and probably the more frequent, has been a misapprehension of their weight and effect on

larger manufacturing population into existence, and thereby re-act on agriculture by increasing the demand for food.

“ ‘ This cheaper mode of internal carriage will not only lower the price of light and refined manufactures to the Home consumer, but will lower their price also to the Foreign consumer. This will increase the advantages which we at present possess in the Foreign market, and tend to increase our Foreign commerce. So that here again there will be an increased demand for manufactures and for a manufacturing population, and here again will be another beneficial re-action upon the soil. So that the more we contemplate the various effects produced upon the industry of the country by a cheaper mode of conveyance, the more we must be convinced that wealth and population will be increased, and that agriculture, instead of being injured, must necessarily partake in the increased prosperity of the country. In addition to what I have already stated, the saving of expense and of time in conveying passengers and goods, and the rapidity of communication, will produce effects, the amount of which it would be almost impossible to calculate.’ ”

roads. Either cause appears to the Committee a sufficient justification for their recommending to the House that legislative protection should be extended to Steam Carriages with the least possible delay.

“ It appears from the evidence, that the first extensive trial of Steam as an agent in draught on common roads, was that by Mr. Gurney, in 1829, who travelled from London to Bath and back, in his Steam Carriage. He states, that although a part of the machinery which brings both the propelling wheels into action, when the full power of the Engine is required, was broken at the onset, yet that on his return he performed the last eighty-four miles, from Melksham to Cranford Bridge, in ten hours, including stoppages. Mr. Gurney has given to the Committee very full details of the form and power of his Engine, which will be found in the evidence.

“ When we consider that these trials have been made under the most unfavourable circumstances—at great expense—in total uncertainty—without any of those guides which experience has given to other branches of engineering; that those engaged in making them are persons looking solely to their own interest, and not theorists attempting the perfection of ingenious models; when we find them convinced, after long experience, that they are introducing such a mode of conveyance as shall tempt the public, by its superior advantages, from the use of the admirable lines of coaches which have been generally established; it surely cannot be contended, that the introduction of Steam Carriages on common roads is, as yet, an uncertain experiment, unworthy of legislative attention.

“ The several witnesses have estimated the probable saving of expense to the public, from the substitution of steam power for that of horses, at from one-half to two thirds.

“ Perhaps one of the principal ‘advantages resulting from the use of steam, will be, that it may be employed as cheaply at a quick as at a slow rate ; ‘ this is one of the advantages over horse labour which becomes more and more expensive as the speed is increased. There is every reason to expect, that in the end the rate of travelling by Steam will be much quicker than the utmost speed of travelling by horses ; in short, the safety to travellers will become the limit of speed.’ In horse draught the opposite result takes place ; ‘ in all cases horses lose power of draught in a much greater proportion than they gain speed, and hence the work they do becomes more expensive as they go quicker.’ On this, and other points referred to in the Report, the Committee have great pleasure in drawing the attention of the House to the valuable evidence of Mr. Davies Gilbert.*

* Mr. Gilbert says:—“ ‘ I have made some further remarks, which I would beg to deliver in also, tending to point out particularly the advantage of steam conveyance when the rate of travelling is great : I would beg to add, that it appears to me extremely difficult to lay down any general rule which would be applicable to all situations and all roads, inasmuch as they vary with the nature of the materials : that up to a certain weight, proportionate to the corresponding width of the wheel, it is probable that the injury to any road may be very little, but that beyond a certain weight, compared again with a corresponding breadth of the wheels, the materials would be entirely crushed and the road totally destroyed ; therefore it follows, that even on all roads there must be a limit to the weight of Carriages, as it is quite impossible that a wheel of enormous breadth could bear uniformly on all its surface. For instance, where trains of artillery are drawn over roads, the excess of their weight beyond what materials are capable of sustaining, has been found sufficient for grinding them to powder. The slow conveyance of heavy weights may perhaps be affected by steam on well-made and

“ Without increase of cost, then, we shall obtain a power which will ensure a rapidity of internal communi-

nearly level roads, so as to supersede the use of horses ; but steam power is eminently useful for producing great velocities. It was last year determined by the Society of Civil Engineers, after much inquiry and discussion, that the expense of conveying Carriages drawn by horses was at its minimum when the rate of travelling equalled about three miles an hour, and that expense increased up to the practical limit of speed, nearly as the velocity : including the greater price of horses adapted to swift driving, their increased feed and attendance, the reduced length of their stages, and, with every precaution, the short period of their services ; on the contrary, friction being a given quantity as well as the force requisite for impelling a given weight up a given ascent, the power required for moving steam carriages on a railway remains theoretically independent of its speed, and practically increases but a very little, in consequence of resistances from the atmosphere, slight impacts against the wheels, inertia of the reciprocating piston, &c. The expenditure of what I have termed Efficiency, is as the actual force multiplied by the velocity, and the consumption of fuel in a given time will be in the same proportion, but the time of performing a given distance being inversely as the velocity, the expenditure of fuel will theoretically be constant for a given distance, and very nearly so in practice. The power requisite for moving bodies through water is the opposite extreme ; here, the mechanical resistance of the fluid increases with the square of the velocity, as do the elevation of the water at the prow and its depression at the stern. The oars or paddles must therefore preserve a constant ratio to the velocity of the vessel ; and the force applied will consequently vary as the squares of the velocity ; and the expenditure of efficiency being as the force multiplied by the velocity, the consumption of fuel will be as the cube of the velocity in a given time, or as the square of the velocity on a given space ; and I have ascertained from the records of voyages performed by steam vessels, that the law is nearly correct in practice : hence the great power required

cation far beyond the utmost speed of horses in draught ; and although the performance of these Carriages may not have hitherto attained this point, when once it has been established, that at equal speed we can use Steam more cheaply in draught than horses, we may fairly anticipate that every day's increased experience in the management of the Engines will induce greater skill, greater confidence, and greater speed.

“ Nor are the advantages of Steam power confined to the greater velocity attained, or to its greater cheapness than horse draught. In the latter, danger is increased, in as large a proportion as expense, by greater speed. In Steam power, on the contrary, “ there is no danger of being run away with, and that of being overturned is greatly diminished. It is difficult to controul four such horses as can draw a heavy carriage ten miles per hour, in case they are frightened, or choose to run away ; and for quick travelling they must be kept in that state of courage, that they are always inclined for running away, particularly down hills and at sharp turns of the road. In Steam, however, there is little corresponding danger, being perfectly controllable, and capable of exerting its power in reverse in going down hills.” Every witness examined has given the fullest and most satisfactory evidence of the perfect controul which the conductor has over the movement of the Carriage. With the slightest exertion it can be stopped or turned, under circumstances where horses would be totally unmanageable.

for such steam vessels as are constructed not merely for speed, but also to set at defiance the opposition of winds and seas ; while, on the contrary, a very small power will be found sufficient for moving ships of the largest dimensions through the water, at the rate of two or three miles an hour, when their sails are rendered useless by continued calms.’

•

A P P E N D I X

To the Report of the Select Committee of the House of
Commons, on Patents.

Papers delivered in by John Farey, Esq.

—

[*British Law of Patents for Inventions.*]

(Continued from page 286.)

•

—

THE patents were assigned by Gamble, in 1804, to H. and S. Fourdrinier, with all interest he might have if an act of Parliament were passed. In 1807, Gamble and H. and S. Fourdrinier obtained an act of Parliament (47 Geo 3. s. 2, c. 131, of private acts), to prolong the term to fifteen years from 1807. H. and S. Fourdrinier became bankrupts in 1810, and then the patents passed to the assignees of bankrupts (the plaintiffs) who held the same for the benefit of more than twenty creditors who had proved debts under the commission. It was objected, that the assignees having the patents assigned to them in trust for more than five persons, contrary to the act, the privilege had become void, and the case of *Hesse v. Stevenson* was cited. Chief Justice Abbott: "The twenty creditors could not grant licenses to use the patent right, but the assignees might. I am clearly of opinion that the privileges passes to the assignees."

The new specification and drawings, enrolled in 1807 under the act, was proved sufficient; the first one of 1801, contained some French terms, and some dimensions expressed in French measures. J. Gamble, the patentee, admitted that he obtained the invention from Leger Didot, a Frenchman, and acted as his trustee in taking out the first patent in 1801, at which time we were at war with France. It was objected that the patent was void, being held in trust for an alien enemy; also it appeared that several of the improvements described in the specification, had been invented by Mr. Donkin, an engineer, who was employed by Fourdrinier and Gamble to bring the machine to perfection.

Chief Justice Abbot: "A patentee is not tied down to make a specification by words alone, but he is allowed to annex drawings; and if by comparison of the words and drawings, the one will explain the other, sufficiently to enable a skilful mechanic to make the machine, it is a sufficient specification. By the act, the

last specification is to be taken as a substitute for the former ones, and being good, supplies all their defects and omissions." His lordship left it to the jury to say whether it was a useful invention, and whether the patent had been infringed by defendant. Verdict for the plaintiffs, with liberty to move for a nonsuit.—Carrington and Payne's Reports of Cases, Nisi Prius, Feb. 1832. Vol. I. p. 558.

On the 27th January, 1825, the Court was moved for a nonsuit or a new trial, on the following grounds :

1st. That when Gamble took out the first patent, in 1801, for an alien enemy, without disclosing that fact, it was a fraud on the Crown. 2d. That the privilege, under the act, could not be assigned or held in trust for the benefit of more than five persons, or their representatives, and the assignees of bankruptcy are trustees for the whole body of creditors. 3d. That the first patent was for a machine to make paper from 1 to 12 feet wide, which the machine described in the first specification could not do; and if the first patent fails, the other and the act fails also. 4th. That four out of five of the improvements mentioned in the second specification, were invented by Mr. Donkin (the case of Barber v. Waldock was cited) and the fifth was no improvement at all. 5th. That the first specification contained French expressions and dimensions, and a scale to the drawing in French measures; and if any part of the specification is bad the whole is so.

Chief Justice Abbott: It was proved that the French names to the scale were quite immaterial; for relative proportion (which was all that was wanted) the scale would have been as good, if their had been no names at all: "I am of opinion that the clause in the act applied only to such assignments as are the act of the party, not to assignments by act of law." Mr. Justice Bayley: "The right of Messrs. Fourdrinier passed by a statutable assignment to the assignees, who are their representatives." Mr. Justice Holroyd: "I think the assignees are the representatives of the bankrupts, and that they may sell the right." Mr. Justice Littledale was of the same opinion. Mr. Justice Bayley: "In the case of Hill v. Thompson, it is laid down that if a servant make an improvement, his master is not entitled to take a patent for it. The court decided that some of the points deserved serious consideration, and therefore granted a rule for a nonsuit or a new trial.

On the 3d February, 1827, another hearing took place in the King's Bench, on the following case :

1st. By the Act 41 Geo. 3, the privilege was to become void in case it should at any time become vested in, or in trust for more than five persons, or their representatives at any one time, otherwise than by devise or succession (reckoning executors and administrators as the single persons they represent); it was

objected that the patent had become vested in the assignees of the bankrupts, in trust, for more than five creditors. Also, 2d. The first patent in 1801, was for a machine for making paper, in single sheets, without seam or joining, from 1 to 12 feet and upwards in width, and from 1 to 45 feet and upwards in length. The second patent, 1803, was for improvements on and additions to the former. It was objected that the machine described in the specification to the first patent, was not capable of making different widths of paper; also that it was not capable of producing useful paper. The Lord Chief Justice reserved the two points, but left the latter to the jury, who thereupon found a verdict for the plaintiffs.

The first point was thus decided by the Judges. Lord Chief Justice Abbott: "In my opinion the whole clause in the Act is confined to assignments by acts of the parties, and does not apply to any transfer by operation of law. Under the Ship Register Acts, which has a similar provision: the assignees of a bankrupt take the interest in a ship." Mr. Justice Bayley: "The bankrupts did not exceed five, and the bankruptcy, by a statutable transfer, has made the assignees the representatives of the bankrupts." Mr. Justice Holroyd: "I think the assignees are to be considered as the representatives of the bankrupts, and not as the representatives of the creditors; although the assignees take the property to convert it into money, and then they hold that money in trust for the creditors." Mr. Justice Littledale: "It seems to me, that the words of the Act do not apply to a transfer by operation of law, the assignees represent the bankrupt by operation of law."

On the other point, Lord Chief Justice Abbott: "The patent was granted on the representation that a machine would make paper in sheets, of width and length varying within the limits designated: if any material part of that representation was not true, the consideration failed in part, and the grant is void: both width and length are important parts of this representation. I think the words mean, that paper of different widths could be made by the same machine, and it is a different thing, whether a manufacturer must get several different machines, or only one accomplishing the purposes of many. Unfortunately the evidence shows, that the patentee was not possessed of the invention of such a machine; I say unfortunately, because it is to be lamented that the advantage of great ingenuity, labour, anxiety and expense, should be lost to those who have bestowed them on a useful invention; he was not then possessed of any method by which different widths might be made by that machine, or any other. By subsequent improvements a machine was obtained, capable of making paper of width varying within certain limits, but not extending to half the width mentioned in

the patent. The specification enrolled by the Act 41 Geo. 3. sufficiently describes such a machine, and a mode of adjusting it to different widths, within the limits of its own breadth, but the first specification is confined to one width only ; and though the Act substitutes the new specification in place of the former ones, it cannot operate retrospectively, to enable the patentee to say that he possessed in 1801, or had then discovered a machine, which he did not possess or discover, until a much later date. If the first machine had been capable of working at different widths, though clumsily and imperfectly, the latter machine would have been an improvement of it, but the first as existing actually or in theory, being wholly incapable, the latter was not an improvement of any thing previously existing, but an addition of new matter, not existing at the date of the first patent, but which was nevertheless represented as then existing, and it was an important part of the representation and consideration, on which the grant was made. If the first grant was void, the subsequent grants by the patent, and the statute, must fall, as having nothing to support them. There must be a new trial, because the question ought to have been left to the Jury, whether the machine, as originally constructed, was capable of making paper of different widths. I did not leave it so to the jury, because the evidence showed it would not.” Rule absolute for a new trial.—Barnwell and Cresswell’s Reports, Vol. VI. p. 169.

Note.—This paper machinery has proved a very valuable invention ; it has come into general use, and together with the modern inventions of machines for printing by steam power, has proved a great public benefit. Messrs. Fourdrinier expended all their means in bringing it to perfection, and were ruined. The creditors recovered a large proportion of their debts from the exercise of the patent right, but were put to vast expenses in the law proceedings, and, after the above opinions of the judges, chose to abandon the patent right rather than proceed to a new trial. The printing machine of Koenig, in like manner proved injurious to Mr. Bensley, who purchased the patent, and went to vast expenses in bringing it to bear. Mr. Applegath, who afterwards improved so much upon the original machine as to supersede the patent right, was also ruined by the expenses, notwithstanding that he made a great number of machines.

The King against Lister. A scire facias to repeal Lister’s patent of 1823, for Improvements in the method and machinery for preparing and spinning Wool, Silk, or other animal fibres. Tried 19th Jan. 1826, in the Court of King’s Bench. Verdict for the Crown.

The proceedings were at the suit of Mr. Hadden, who had a

patent in 1818 for an invention which was proved to be substantially the same as that described in Mr. Lister's specification. It was for applying heat to the fibres of wool during the operation of spinning it. Mr. Hadden did this by inserting hot iron heaters into hollow rollers between which the slivers of wool passed. Mr. Lister effected the same thing, by applying steam within the hollow rollers, and he also caused the slivers previously to pass through water so as to become wetted, in order to soften the fibres before they came between the heated rollers. It is said that Mr. Lister, at the time of this trial, had granted licences under his patent to the amount of 3000*l.* per annum.

The King against Hadden. A scire facias to repeal Hadden's patent of 1818, for an Improvement in preparing, spinning, and roving Wool. Tried 19th Jan. 1826, in the Court of King's Bench. Verdict for the Crown.

The proceedings were at the suit of Mr. Lister, who had a subsequent patent in 1823, for the same invention, and which was set aside in the previous trial as above. It was proved that the principle of Mr. Hadden's invention had been used long before his patent.

Hills and Haddock against Thompson and Hill. An Action for infringement of Hill's and Haddock's patent of 1818, for an Improvement in the manufacture of Sulphuric Acid.

The improvement is to employ iron pyrites, or other metallic sulphurets as a material for producing sulphuric acid, by burning the same in close chambers, and condensing the sulphureous vapour proceeding from the combustion, into sulphuric acid, by the aid of atmospheric air and steam. The patent was supported.

Barton against Hall. An Action for infringement of Barton's patent of 1816, for Improvements in Metallic Pistons for Steam Engines. Tried in the Common Pleas, 11th July 1827, before the Chief Justice. The Patentee was nonsuited.

The pistons, which were alleged by the plaintiff's witnesses to be infringements, were not, in the opinion of the judge, the same invention as that described in his specification, but were substantially the same as the metallic pistons commonly used long before the patent.

The King against Fussell. A scire facias to repeal Fussell's patent of 1824, for an improved method of heating Woollen Cloth, for the purpose of giving it a lustre in dressing. Tried in the King's Bench in July 1827, before the Lord Chief Justice. Verdict for the Crown.

The proceedings were at the suit of Mr. Daniell, who had a patent in 1819, for a similar process, and which he had brought into very extensive use, with great advantage. After the sur-

face of the cloth has been properly dressed, and the nap on the surface laid very smooth, the piece is rolled up very smoothly and evenly, in a close and compact roll; that roll being immersed in hot water for a sufficient length of time, the fibres of the wool become softened, and after this process they acquire a tendency to retain the same direction; and thus the effect of the dressing is rendered permanent. Mr. Fussell's process being the same, except that he submitted the roller to steam instead of hot water; it was held to be substantially the same invention, and his patent was repealed.

The King against Daniell. A scire facias to repeal Daniell's patent of 1819, for Improvements in dressing Woollen Cloth. Tried in the King's Bench in July 1827, before the Lord Chief Justice. Verdict for the Crown.

The merit and utility of the invention were fully proved, as stated in the preceding trial. One witness was brought to prove that he had practised the same method some years before the date of the patent; he swore that he operated exactly as directed in Daniell's specification, but he could not make out that he had pursued the method, or that he had attained any good result by it, nor was any corroborating evidence given. On this evidence the patent was repealed.

Crosley against Beverley. An Action for infringement of one part of Clegg's Patent of 1815, for an improved Gas Apparatus, that Patent being assigned to Crosley. Tried in the King's Bench, 20th January 1829, before Lord Tenterden. Verdict for the Patentee.

The specification describes a series of apparatus, constituting a complete apparatus for gas lighting, viz. a retort; a purifying apparatus; a gas meter, for measuring the quantity of gas supplied from a particular gas-holder, or to any particular purchaser; and a governor for regulating that supply and making it uniform. The infringement was on the gas-meter. Of this series only the gas-meter and the governor have been brought into use; all the others, after being used some time, were laid aside; it was proved that they would, and did, answer the purposes proposed, and that they were clearly described; therefore the patent was supported by the Court. The gas-meter which was the subject of the action, has been greatly improved in construction beyond what is described; but the improved meter was proved to be the same invention, although executed in a simpler and better form than those described in the specification.

The specification stated the improved apparatus to be for extracting gas from "pit-coal, tar, or any other substance from which gas capable of being employed for illuminating, can be extracted by heat." It was objected that the retort was inca-

pable of extracting gas from oil, except very imperfectly, and by the aid of considerable modifications, not provided for by the specification. Lord Tenterden: "I must look at the whole of the specification together, and I think it is evident that it only represents the retort as suited to materials of the same kind as coal. I understand, 'other substances' to signify substances then known to be available for illuminating with gas, not every thing which will burn with a flame, for in a certain sense all those produce gas. The evidence states, that oil was not then generally considered as such a substance; and the fact, that some speculations were going on at the time, with respect to its being so, will make no difference. The patentee cannot be required to foresee the success of those speculations, but I must consider him as a practical man, to have spoken of things which practical men then treated as usable for the specified purpose. I must decide against the objection. The law is severe enough in breaking up patents altogether, for a fault in any part of them, without straining it in favour of such an objection."—Moody and Malkin's Reports, Vol. I. p. 283.

On the 27th January 1829, Motion was made for a new Trial, but it was refused.

Mr. Clegg, the inventor, having assigned all his interest, had been examined as a witness on the trial; from his evidence it appeared, that at the time he applied for his patent, he had conceived the idea of his gas-meter to be a hollow wheel, partly immersed in water, its interior being divided into chambers, which were to be alternately filled and emptied with gas, in such manner as to cause the wheel to turn round on its axis, in order to measure and record the quantity of gas which passed through those chambers: he made no drawing or model, until after he obtained the patent, and then he made a meter, which is described in the specification: but finding its structure too complicated for general use, he set about another, which is also described in the specification. From this it was objected, that an important part of the invention had been made after the date of the patent, and could not therefore have been included in the representation made to the Crown, as the consideration of the grant.

Mr. Justice Bailey. At the time he took out his patent he had discovered a new method, but between that, and the time he made out his specification, he discovered certain improvements; would not his patent be bad if he had not specified those improvements?

Mr. Justice Littledale. The general statement made in the Petition to the King, viz. "a Gas Apparatus," is equally applicable to the present specification, and to what that specification

would have been, if it had been confined to what was passing in his mind at the time he petitioned for his patent.

Lord Tenterden. "The objection really is, whether a patent is void, when the inventor having had in his mind, at the time of applying for it, an invention capable of producing the effect he represented it to be capable of producing; but having brought that invention to a greater degree of perfection within the time allowed by his patent for making the specification, he introduces into that specification a different species of mechanical parts from those he first conceived. No case has ever decided that, and I think it would be extremely dangerous to lay down any such doctrine; I do not see why time is allowed to prepare a specification, except upon the idea that the inventor has not, at the time of obtaining his patent, brought his invention to the degree of perfection that he may be supposed to be capable of doing, and therefore he is allowed further time to do it. If in the interval the invention is perfected, so as to approach to a perfect accomplishment of the object originally in view; I do not see that it can be any objection to the patent."

Mr. Justice Bayley. "I think the specification and the patent are to be taken together as one muniment for enforcing the claims of the patentee. The specification with the new improvement, which has been found out since the date of the patent, would still be the invention for which the patent was obtained. I think it most beneficial to the public, and best answering the purpose of the Act of Parliament to say, that if between the period of taking out the patent, and enrolling the specification, the inventor makes discoveries which will better effect the object for which the patent was obtained, not only he is at liberty, but it is his bounden duty, to introduce the same into his specification; and that it is not sufficient for him to communicate to the public the knowledge which he had at the time he petitioned, or when he obtained his patent, but he ought also to communicate all the knowledge that he has attained before lodging the specification. I am of opinion that the objection taken to the patent in this case is not to be supported."

Mr. Justice Littledale. "I am also of the same opinion. This patent was taken out for an improved gas apparatus; at the time of applying for it, the inventor had some ideas in his mind which gave him a prospect of doing something beneficial to the public, on that the grant was made, with time allowed for making out a specification. He might be called upon to do it immediately, but time is given.

In that time something contributing materially to the suc-

cessful practice of the invention comes into his mind ; he finds it will answer, and introduces it into his specification. Now it can only be upon a very strict technical rule, that such addition in the specification to what was passing in his mind when he applied for the patent would render that patent void. It has been held, that if a man applies for a patent for two things, and he is not the inventor of one, or there is some objection to one of them, the whole is void, because it is considered that he made an unfair representation, and obtained a patent unfairly thereupon ; and if any one part fails, the whole is to fail also. That appears to me to be only a technical rule, intended to prevent frauds in obtaining patents, or for some other reason, but there is no reason why it should be carried farther than it has been. For the same reason, if any part of the specification is bad from any cause, it may render the whole void. In this case no deception was practised on the crown ; the inventor professed to give a gas apparatus, and has done so ; nor is any deception practised on the public, for until the enrolment of the specification, the public were unacquainted with the mode in which the invention is to be carried into effect. At first it was merely floating in his mind, but his mind having got into an improving state, is able to give an improvement of a certain value when he petitions the crown for a patent ; afterwards, as he puts up the machine, to try if it will answer, and to see that the intended specification will be right, he finds from day to day how to increase the original value, perhaps to double it ; surely it would be a hardship, if for thus giving the public a double mode, and adding (when he ascertains the patent) an improvement of double the value of that which was passing in his mind when he applied for his patent, that the whole should be void, and that he should be deprived of the benefit, because he had not in his specification confined his communication to what was passing in his mind at the time his patent was sealed. I think that would be very unjust, and I know of no rule of law by which it should be.

Felton against Greaves. An action for infringement of Felton's Patent of 1827, for a machine for sharpening Knives, Scissors and Razors. Tried in the King's Bench 6 June 1829, before Lord Tenterden. Patentee nonsuited.

The description in the specification was judged incomplete because it would not enable persons to make a machine for sharpening scissors.

Scotch Patents.

*List of Patents granted in Scotland from 20th December, 1830,
to 4th March 1831.*

To Thomas Walmsley, of Manchester, manufacturer, for the invention of improvements in the manufacture of cotton, lincn, silk, and other fibrous substances, into a fabric or fabrics applicable to various useful purposes.—Dec. 20,

To Charles Stuart Cochrane, of Great George Street, Westminster, Esq. a Commander in the Royal Navy, for the invention, communicated to him by a foreigner residing abroad, of certain improvements in the preparing and spinning of cashmere wools.

To Robert Dalglish, jun. of Glasgow, calico-printer, for the invention of improvements in machinery or apparatus for printing calicoes and other fabrics.

To John Hall, jun. of Dartford, in the county of Kent, engineer, for the invention, communicated to him by a foreigner residing abroad, of a machine, upon a new and improved construction, for the manufacture of paper.—Dec. 28.

To William Needham, of Langour, in the county of Stafford, gentleman, for the invention of certain improvements in machinery for spinning, doubling, and twisting silk, and other fibrous substances.—Jan. 14.

To Francis Molineux, of Hampstead, in the county of Middlesex, gentleman, and William Bundy, of Kentish Town, in the same county, engineer, for the invention of certain improvements in machinery for spinning and twisting silk and wool, and for roving, spinning, and twisting cotton, flax, hemp, and other fibrous substances.—Jan. 18.

(In place of a former one) To John Ericsson, of the New Road, London, engineer, for the invention of an improved engine for communicating power for mechanical purposes. *

To Samuel Clegg, of No. 16, Sidmouth Street, Gray's Inn Lane, in the county of Middlesex. civil engineer, for the invention of an improved gas-meter.—Jan. 19.

To Thomas Bulkeley, of Upper Gloucester Street, New Road, in the county of Middlesex, doctor of medicine, for the invention of a method of making or manufacturing candles.—Feb. 2.

To James Thomson, of Spencer Street, Goswell Street Road, in the county of Middlesex, gentleman, for the invention of certain improvements in making or producing printing types.—Feb. 18.

To Richard Roberts, of Manchester, in the county of Lancaster, civil engineer, for the invention of a certain improvement or certain improvements, in the mechanism employed to render self-acting machines, known by the name of mule, billy, jenny, jack frame, or stretching frame, and all machines of that class, whether the said machines be used to rove, slab, or spin cotton, or other fibrous substances.

To Augustus Graham, citizen of the United States of America, but now residing in West Street, Finsbury, in the city of London, gentleman, for an invention communicated to him by a foreigner residing abroad, of certain improvements in the application of springs to carriages.

To William Wedd Tuxford, of Boston, in the county of Lincoln, miller, for the invention of a machine or apparatus for cleansing or purifying wheat, grain, or other substances.

New Patents Sealed, 1832.

To George Vaughan Palmer, of the parish of St. Swithen's, Worcester, artist, for his having invented certain improvements in machinery or apparatus for excavating, and which he calls an excavating and self-loading cart.—24th January.—6 months.

To Joseph Maybury, John Maybury, and Joseph Maybury the younger, of Belton, in the county of Stafford, iron masters, for their having invented certain improvements in polishing or planishing, and manufacturing or

making of ladles, spoons, and other articles for culinary, domestic, and other purposes, made of iron and tinned.—24th January.—2 months.

To James Perry, of Red Lion Square, in the county of Middlesex, bookseller and publisher, for his having invented an improvement or improvements in or on pens.—28th January.—6 months.

To John Jellicorse, of Stansfield mill, in the county of York, for his having invented and found out certain improvements in spinning machinery.—28th January.—2 months.

To William Lloyd Wharton, of Dryburn, in the county of Durham, Esq. for his having invented certain improvements in engines for raising or forcing water by the pressure and condensation of steam.—30th January.—2 months.

To Collin Smith, of Great St. Helens, Bishopsgate, in the city of London, merchant, in consequence of a communication made to him by a certain foreigner residing abroad, for an invention of an apparatus or machine for regulating the course and action of fluids and liquors, which apparatus or machine is applicable to various purposes.—31st January.—6 months.

To Thomas John Fuller, of the Commercial Road, Limehouse, in the county of Middlesex, civil engineer, for his having found out and invented a new or improved mode or process for raising water or other fluids.—31st January.—6 months.

To William Church, of Bordsley Green, near Birmingham, in the county of Warwick, Esq. for his having invented or found out certain improvements in apparatus to be employed in the transportation of goods or passengers, parts of which said improvements are also applicable to the ordinary purposes of steam-engines.—9th February.—6 months.

To John Ericsson, of Liverpool, in the county palatine of Lancaster, civil engineer, for his having invented or found out an improved engine for communicating power for mechanical purposes.—9th February.—6 months.

To John Heathcoat, of Tiverton, in the county of Devon, lace manufacturer, for his having invented or found out a method or methods of ornamenting, embroidering, or working devices upon lace, net, and other fabrics.—16th February.—6 months.

To John Sutton Nettlefold, of Red Lion Street, Holborn, in the county of Middlesex, ironmonger, for his having invented an improvement or improvements in table furniture, applicable to other purposes.—16th February.—6 months.

To George Solomons and Elias Solomons, of Bedford Square, in the parish of Stepney, in the county of Middlesex, opticians, in consequence of a communication made to them by a certain foreigner residing abroad, for an invention of improvements in preparing certain transparent substances for spectacles and other purposes.—16th February.—6 months.

To Richard Atkinson, of Huddersfield, in the county of York, woollen-cloth manufacturer, for his having invented or found out an improved machine or method for raising or brushing woollen-cloths and other goods.—16th February.—6 months.

To William Church, of Heywood House, Bordsley Green, near Birmingham, in the county of Warwick, gentleman, for his having invented or found out certain improvements in machinery for making nails.—25th February.—6 months.

CELESTIAL PHENOMENA, FOR FEBRUARY, 1932.

1 0 0	Clock before the ☉ 12 m. 35 s	19 20 29	♂ passes the meridian.
1 0 0	☉ rises 6 h. 34 m. sets 5 h. 26 m.	19 21 57	♀ passes the meridian.
1 16 0	☾ in conj. with ♃ lon. 6 in Aquarius ☾ 2. 7 S ♃ lat. 55 S. diff. of lat. 1 12	20 0 0	☽ Clock before the ☉ 7 m. 36 s.
1 23 8	♀ passes the meridian	20 2 11	☾ in Aries.
2 3 14	Ecliptic conj. or ● new moon	21 21 18	♃ passes the meridian.
5 0 0	Clock before the ☉ 11 m. 43 s.	23 20 41	☾ in ☐ or last quarter
6 0 0	☉ rises 6 h. 24 m. sets 5 h. 36 m.	24 6 0	☾ in Apoge
7 11 40	♃ passes the meridian	24 18 44	☾ passes the meridian
7 21 43	♀ passes the meridian	24 0 0	☽ Occult. of π Sag. Im. 16h. 28 m Em. 17h. 49 m.
10 5 0	occult. of Aldebaran behind the moon, Im. 12h. 3m. mean time Em. 12. 4. 9.	25 0 0	☉ rises 5 h. 47 m. sets 6 h. 13 m.
8 1 0	♀ in conj. with ♃ long. 8. 0. in Aquarius, ♀ lat. 56 S. diff. of lat. 12.	25 0 0	Clock before the ☉ 6 m. 4 s.
8 5 0	♃ in conj. with γ in Taurus	25 22 4	♀ passes the meridian
9 7 13	♃ in ☐ or first quarter	26 22 0	☾ in conj. with ♂ long 11 in Cap. ☾ lat. 0. ♂ lat. 1. 5. S. diff. of lat. 1. 5.
10 0 0	☉ rises 6 h. 17 min. sets 5 h. 43 min.	27 12 0	☾ in conj. with ♃ long 17 in Cap. ☾ lat. 33 S. ♃ lat. 1. at. 39 S. diff. of lat. 6.
10 0 0	Clock before the ☉ 10 m. 28 s.	28 21 57	☾ Passes the meridian.
11 7 49	♃ passes the meridian	29 3 0	☾ in conj. with ♀ long. 9 in Aquarius ☾ lat. 2. 16. S. ♀ lat. 57 S. diff. of lat. 1. 19.
11 19 0	♀ in conj. with ♃ long. 17. in Cap. ♀ lat. 22 S. ♃ lat. 39 S. diff. of lat. 17	29 4 0	♂ in conj. with ♃ in Cap.
12 3 0	♃ in perige	30 0 0	☉ rises 5 h. 37 m. sets 6 h. 23 m.
19 23 8	♃ passes the meridian	30 0 0	Clock before the ☉ 4 m. 31 s
14 2 0	♃ in conj. with α in Leo.	31 17 2	Ecliptic conj. or ● new moon
15 0 0	Clock before the ☉ 9 m. 5 s.		
15 1 0	♃ in conj. ♃ with long. 10° in Leo. ♃ lat. 2. 57. N. ♃ lat. 2. 8. N. diff. of lat. 19.		
16 0 0	☉ rises 6 h. 5 m. sets 5 h. 55 m.		
16 3 22	Ecliptic oppos. or ○ full m.		
17 13 12	♃ passes the meridian.		

None of the eclipses of Jupiter's satellites are visible in London this month.

The waxing moon ♀.—the waning moon ☾

J. LEWTHWAITE.
Rotherhithe.

SECOND SERIES
Bernhardt's Apparatus for raising Water

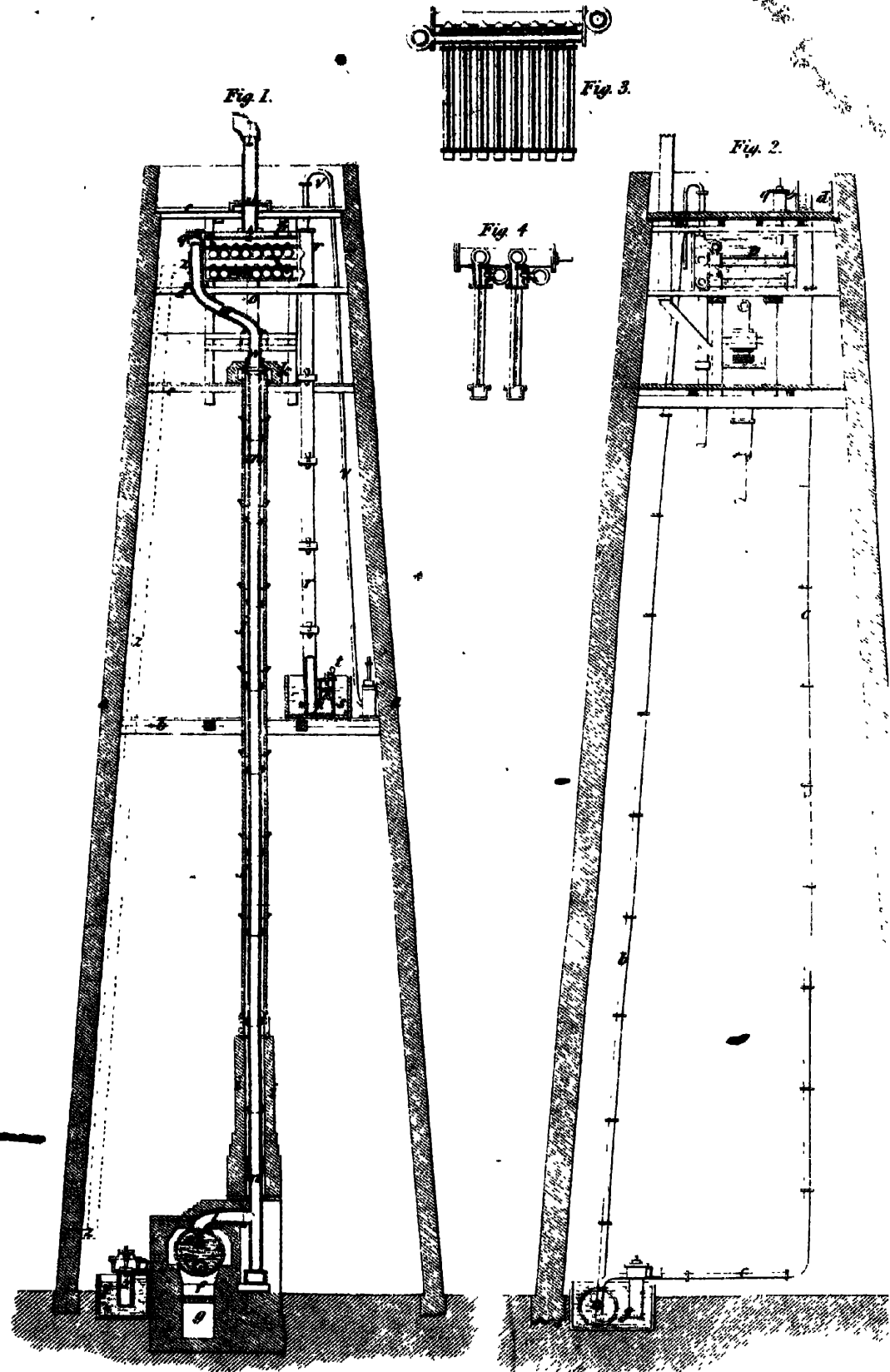

W Newton del

17 July 1824

Sydney's Machinery for making Nails, Screws, &c.

Fig. 1.

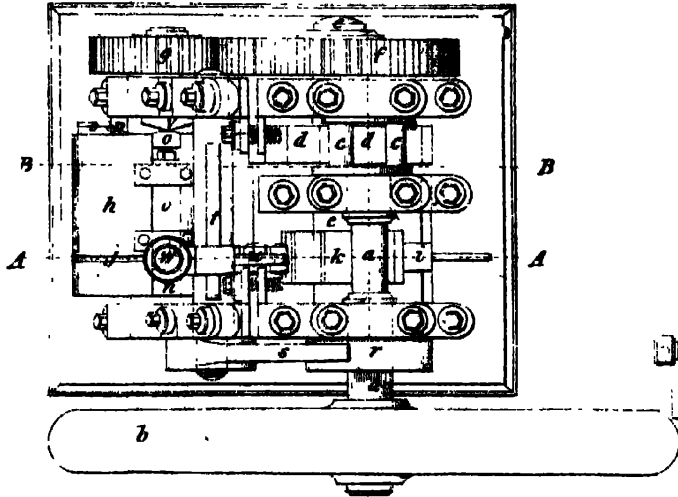

Fig. 2.

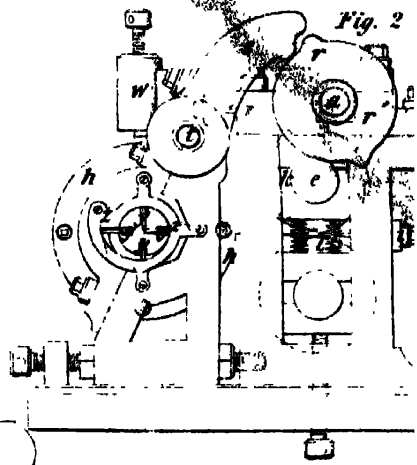

Fig. 3.

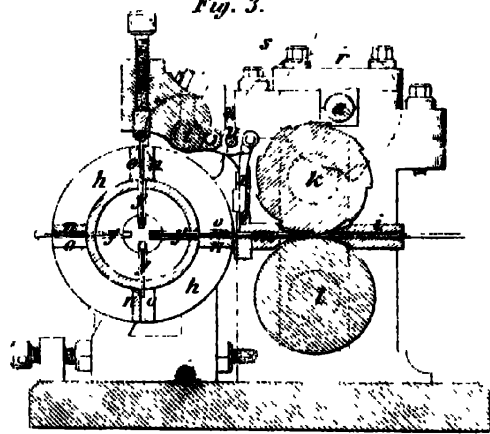

Fig. 4.

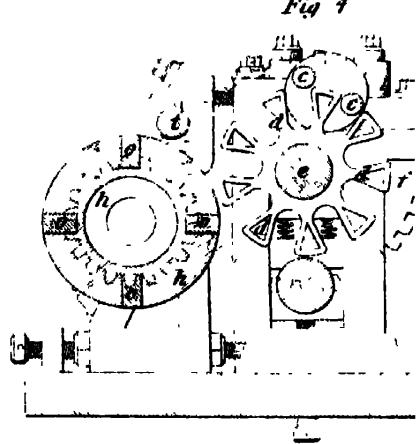

Fig. 5.

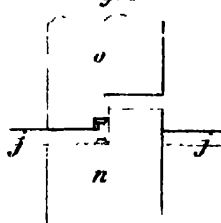

Fig. 6.

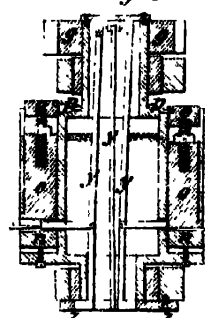

Fig. 10.

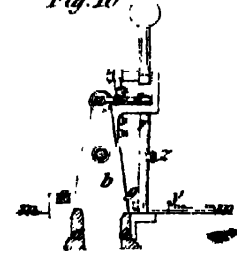

Fig.



Fig.



Fig. 13.



Fig. 7.

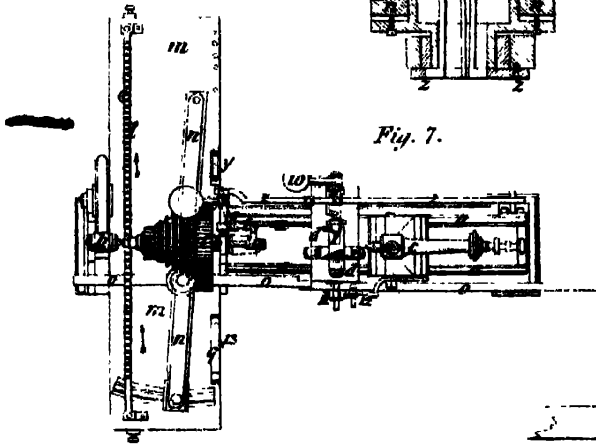
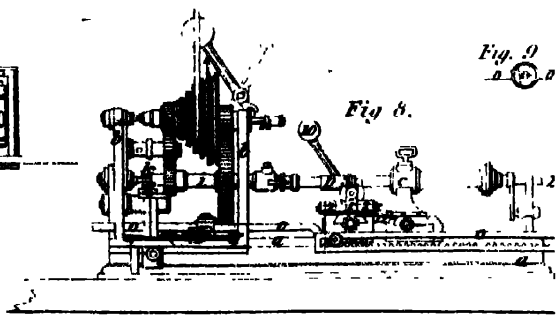

Fig. 9.



Fig. 8.



THE

London

JOURNAL OF ARTS AND SCIENCES.

No. XVI.

[SECOND SERIES.]

Original Communications.

ART. XII.—ON GAS METERS.

To the Editors of the London Journal of Arts, &c.

GENTLEMEN,—The Patent for gas meters taken out by Mr. Clegg, the inventor, has, or is about to expire, therefore my remarks following cannot injure the Patentee, or his representative, Mr. Crosley, to whom the Patent right appears to have been sold.

The meter is perhaps the most ingenious piece of machinery connected with gas ; but in its present state, particularly the small ones, in most cases, are attended with great trouble and uncertainty of measurement ; and sometimes with very considerable danger. Wherever there is an accumulation of gas, as in the meter, there is danger. In frosty weather the meter is frozen, and in that state the meter cannot give light. At

times the water evaporates or escapes through the leakages ; and at other times it rises, by means of condensation, above the prescribed level. Excess of water creates a loss to the consumer ; but, as is too often the case, a diminution of water creates a loss to the manufacturer, rendering the light feeble and uncertain at the same time. If the water indeed falls beyond a certain extent, total darkness is the consequence. No gas can in that case pass through the meter. In short, the attention required to small meters, and the anxiety and trouble they create are incalculable. At a meeting of the consumers of gas, in Hull, and reported in the *Hull Advertiser*, of 23d March, 1827, the real merits of the small gas meters were pretty well exposed. It was then stated that they could not be relied on as a correct measure of the gas consumed. There were not two of them which were found to register alike. Indeed, instances have occurred at Stratford, in the shops of Mr. Rowley, grocer, and of Mr. Norris, chemist, where gas passed through these small meters in 1823, without their registering at all ! and there were many instances in that quarter of their registering pretty freely, without giving the corresponding quantity of gas. Mr. Pill, confectioner, in the Mile End Road, for instance, reduced his number of burners, and yet found no diminution in the registering of his meter ! There is nothing like speaking to facts. They are worth a thousand vague assertions. On the whole, it would have been for the interest of the gas manufacturers that those *ingenious* machines had never appeared. There are cases where a restraint, if only a moral restraint, on consumers is necessary ; but generally speaking, the manufacturer has been a considerable loser by the use of the meters. This is not right. A company, or an individual making a capital, to produce an article of utility, is entitled to a profit—to even a *handsome profit*, for his enterprize and risque. The managers are *gulled*, and their companies are the sufferers. This is not indeed always the case, for there are some managers who have both shrewdness and a sufficient portion of practical knowledge, to stand firmly

between the interest of their company and the importunities and gross flatteries of interested individuals. Such companies continue to divide a good profit, and can afford to give a bonus occasionally. Now to *facts*. •

A respectable tradesman, Mr. S. No. 11, Waterloo Place, Edinburgh, used

3 Argands, of 15 holes.

4 Ditto, of 10 holes.

1 Jet, of 3 holes.

The jet was used in the kitchen till eleven or twelve o'clock ; one of the four argands at the top of the stair, outside the door, till eleven or twelve ; the other three till seven or eight o'clock. The three argands of fifteen holes were used for show rooms and cutting rooms pretty late, say till ten o'clock on an average. By the Edinburgh scale, the price of all these several burners would have been per annum, as follows:—

Three argands, of fifteen holes (none above ten holes are allowed by the scale, at £.4 4s. each), say,	£.12	12	0
1 Ditto, of 10 holes, till 11 o'clock	-	5	4
3 Ditto, ditto, 8 o'clock	-	6	0
1 Jet, of 3 hours, till eleven o'clock	-	3	0
		<hr/>	
	£.26	16	0

This account by the meter from 5th Feb. 1827, to 6th Feb. 1829, was actually as under:—

From 5th Feb. to 9th May, 1827, 2,083 feet of gas, at 12s. per 1,000	£.1	5	0
From 9th May, to 3rd Nov. 2,507.-		1	14
From 3rd Nov. to 6th Feb. 1828, 7,089		4	11
		<hr/>	
	£.7	11	2

Lost to the company £.15 4 10

The gas could not have been more profusely used without

enlarging the holes, than was used by Mr. S. from Feb. 1827, to Feb. 1828.

Another case. Messrs. Y. and M. cloth manufacturers, Luckenbooths, Edinburgh, first used four argands, with oil, entirely, which cost them £.18 per ann. They then used four gas argands of ten holes, till eight o'clock, at £.2 each—£.8. After that they obtained a meter, when their rental did not exceed £.4 or £.4 4s. Let the losses in these cases be multiplied into the number of customers using meters, and observe the aggregate annual loss to the company! The consumers in Edinburgh are just admirers of the meter. No wonder. But the singularity is the actual *encouragement* given by the adoption of the generality of companies themselves! They are told that they save by it—*save by it!* Read the foregoing, and say how that can happen? The consumers are more economical they say; and shut up in good time. Let this be admitted. What does it amount to? In the last mentioned case of the cloth merchants, let it be supposed that they should be opened a quarter of an hour sooner than they did when they burned by the scale. For 235 days at $3\frac{3}{4}$ feet per hour, this would amount to a saving of about 708 feet.

It is quite clear, that for the sake of show and business, the quantity of light, during the hours of actual business, *could not be very easily diminished.* But allow for that 1,000 feet; or say, on the whole, 2,000 feet of saving. This at 12s. would be £.1 4s. to be added to the £.4 4s. making the sum of £.5 8s. still leaving a loss of £.2 12s. annually to the good-natured company. How is this to be made up? They have allowed the consumers to get too wise on this head. Who's fault is that?

W. T.

16th June, 1829.

ART. XIII.—DESCRIPTION OF AN IMPROVED APPARATUS TO ILLUSTRATE THE RADIATION OF LIGHT AND HEAT. COMMUNICATED IN A LETTER TO THE EDITORS. BY KNIGHT SPENCER, ESQ.

To the Editors of the London Journal of Arts, &c.

GENTLEMEN,—I have experienced great difficulty and lost much time in adjusting the reflectors for showing the radiation and reflection of heat as they are commonly mounted by opticians, which is by sliding them upon a rod which passes through a brass slide, soldered to the back of the reflector, and furnished with a nut and screw to fix them to the rod; and I have seen a lecturer, after 10 or fifteen minutes spent in attempting the adjustment of reflectors mounted in this way, give up the point.

To remedy this inconvenience, I have mounted my reflectors in the way shown by the annexed drawing and description, by which I can at any time adjust them in two or three minutes so accurately as never to fail in my experiments. Should you think this improvement will be acceptable to your readers, it is at your service.

I am, Gentlemen, Your's, &c.

KNIGHT SPENCER.

West Brixton, May, 1829.

REFERENCE TO THE FIGURE.

a, a piece of dry inch deal board, framed twenty-six inches long by eighteen inches wide.

b, upright pieces, with grooves to hold the reflector, twenty-four inches high.

c, a piece of deal board to strengthen the uprights and receive the edge of the reflector, grooved for this purpose.

d, an upright strengthened by a board the same as *c*, and firmly fixed to it exactly in the centre.

- e*, notches in the board *a*, exactly one inch from the edge.
f, a small hole in the centre of the reflector, exactly opposite to
 site to
g, in the back support or uprights.
h, h, reflectors.
i, the dotted lines show the string.

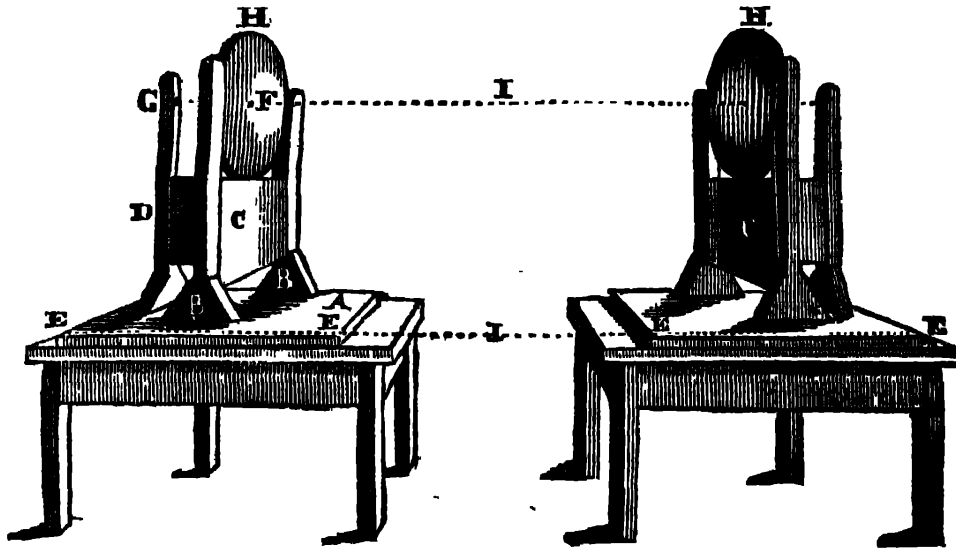

To adjust the reflectors when placed opposite each other, lay a small string from *e*, the back notch of one to the back notch of the other reflector, and when the string cuts or lies over the front notches, the adjustment is complete.

To find the proper height of the object to be experimented upon, put the string through the holes *f*, in the centre of the reflector, and the holes *g*, in the back uprights, bring the object to it and it will be in its true place; the same adjustment answers for the red hot ball in the opposite reflector.

Lastly.—To find the burning point or focus of the reflectors, measure the diameter (or the chord of arc, as the mathematicians call it), of the reflector. Suppose this to be eighteen inches, then lay a flat ruler over it, and measure the depth of the curve. Suppose this to be three inches—then by the rule of three, say as three inches the depth of the curve is to half the diameter nine inches, so is nine inches to the depth of the remaining arc of the circle; lastly, when found, add this to the

three inches, the depth of the curve as above, and this gives the diameter of the sphere of which the reflector is a segment ; the focus or burning point is one fourth of the diameter of this sphere—nearly

Ex. As 3: 9: 9
9

3) 81 (27 inches.

3 inches added as above,

30 inches, one fourth is $7\frac{1}{2}$ inches, the burning point of the reflector from the centre thereof nearly.

NOTICE.

THE Select Committee of the House of Commons, appointed to report on the propriety of revising the Laws relating to Patents for Inventions, having closed their sittings, and ordered the Evidence taken to be printed, we consider it desirable to refrain from any further observation on that subject for the present ; intending to put our readers in possession of the information elicited by the Committee ; after which we shall be open to any further remarks and suggestions connected with that important consideration, and trust that our Correspondents will admit this as an apology for withholding their communications.

Recent Patents.

To ANTON BERNHARD, of Finsbury-square, in the county of Middlesex, Engineer, for a method, principle, or apparatus for raising Water or other Fluids.—[Sealed 24th July, 1828.]

IN the second volume of our present Series, page 342, we mentioned this invention for raising water, the specification of which we are now about to lay before our readers, having delayed our report until we were permitted to see the apparatus in action.

Nearly contiguous to the Surrey Canal Bridge, in the Kent Road, about three miles from London, this hydro-pneumatic apparatus is constructed, in a tower of about seventy feet high, to the top of which water is raised by the contrivance about to be described, and which we shall give in the words of the Patentee.

SPECIFICATION.

“ My invention consists in a method of raising water and such other fluids as are subject to the same laws, as far as regards the application of this invention thereto, by means of an apparatus acting on the combined principles of exhaustion, atmospheric pressure, heat, and condensation, or refrigeration; and which principles are simultaneously brought into action by a new combination of the air pump, furnace, condensor or refrigerator, and torricellian column.

“ The manner in which my said invention is to be performed will be seen by the following description thereof, reference being had to the drawing annexed, and to the figures and letters marked thereon; that is to say, Plate VIII. fig. 1, is a vertical section, through the centre of an apparatus constructed on the principles of my said invention,

and adapted for the raising of water to the height of 50 feet; *a, a*, are supposed to be two sides of an elevated tower, say about 100 feet high; *b, c, d*, and *e*, are four boarded platforms or stories, in the said tower, and some of the other parts merely represent the wooden frame-work which supports part of the apparatus; *f*, is an ordinary furnace; *g*, is the ash pit; *h*, is an ordinary circular boiler, set in the furnace, the flue of which, after passing round the boiler, passes into the brick chimney stack *i*, and is thence carried upwards through the iron funnel *j*, to the brick chamber *k*, whence the smoke is carried off by a smaller branch funnel *o*, which being at the back of this figure, cannot conveniently be shown here; *l*, is a pipe leading from the boiler to the main pipe *m, n*, which is the pipe through which the water is raised in a heated state, and which I therefore call, by way of distinction, the hot fluid ascending pipe.

“ It will be observed that this pipe *m*, passes up the centre of the chimney *i, j*, until it reaches the chamber *k*, at which place the chimney and the main pipe take different directions, the latter being turned to one side at *n, n*, in order to pass by the box at *p, p*, which contain a series of small pipes, which I call the condensing or refrigerating pipes.

“ The hot fluid ascending pipe *m, n*, communicates with the upper part of these pipes at *q*, as will be more particularly explained hereafter. That portion of the hot fluid ascending pipe, from *q*, to *w*, is separate from the lower part, the point of union being at *w*, where there is a stuffing box, which allows the pipe to adjust itself, as it is extended or contracted in length by the variations of temperature to which it is exposed.

“ The vertical part of the pipe *m, n*, which extends below the pipe *l*, is merely for the purpose of support, and to obtain a firm foundation for the whole.

“ It will be seen that there is a box at the lower extremity of the pipe, to receive any dirt that may collect, and which box is furnished with a door to remove the said dirt.

“ The condensor or refrigerator consists of a series of small pipes, communicating with each other (shown in the horizontal fig. 3, and sidewise at fig. 4), and all enclosed in a strong wooden case, through which a current of cold air passes; the manner in which this current of cold air is admitted into the box or casing, which surrounds the condensing or refrigerating pipes, is not shown in figure 1; but the pipe *u*, is the exit pipe for the air, by which it leaves the box, after having performed the operation of condensing or cooling the water in its passage through the condensing or refrigerating pipes.

“ This pipe *u*, should rise about twenty-five feet above the condensor or refrigerator, which communicates at the side opposite to *q*, with the pipe *r*, *r*, *r*, through which the cooled water is carried off, and descends into the cistern *s*; wherefore I call this pipe *r*, for distinction's sake, the cooled fluid descending pipe; *s*, is a cistern kept sufficiently full of water, to seal the end of the pipe *r*; and *t*, is a valve to be applied for the same purpose, when occasion requires; *v*, is an exhausting pipe, leading from the top of the pipe *r*, to an air pump, situated near the cistern *s*, on the first floor *t*, of the building; *j*, is the funnel, or continuation of the chimney, and forms a sort of jacket round the main or hot fluid ascending pipe, which is within it; *x*, *x*, is furnished with a valve opening upwards, to admit water to the boiler, but preventing the return of any water which has once entered. The air pump may be worked by hand or by power, derived from the apparatus itself.”

The Patentee here describes an air pipe, which may pass up the building as a blower to cool the refrigerator, and also the construction of the refrigerator itself, which is proposed

to be made of a series of pipes combined and immersed in a vessel of cold water; but as these parts of the apparatus are disclaimed, and any other mode of cooling which may be found convenient, proposed as applicable, it will not be necessary to extend the explanation to the particular construction of those parts. The specification proceeds—

“ I will now describe the mode of setting the apparatus to work, and its general action. A constant supply of water, either natural or artificial, must be furnished to the reservoir *y*, so as to keep the water line constantly to the height here shown, or nearly so; water must also be supplied to the cistern *s*, sufficient to fill the pipe *r*, at first setting the apparatus to work, but afterwards enough to fill the cistern to the height here shown, will be sufficient; this being attended to, the air pump should be worked by hand or otherwise; this will of course produce a partial vacuum in the exhausting pipe *v*,—the pipe *r*,—the condenser or refrigerator,—the pipe *m*, *n*,—the branch pipe *l*,—the boiler *h*,—and the feed pipe *x*, *x*; the consequence of which will be that the pressure of the atmosphere on the water in the reservoir *y*, will force a portion of that water through the pipe *x*, *x*, into the boiler, and thence into the main pipe *m*, *n*, up which it will ascend to a certain height, according to the perfection or imperfection of the vacuum created by the air pump, at the same time a similar operation is going on in the pipe *r*, for the valve *t*, being opened, the pressure of the atmosphere on the surface of the water in the cistern *s*, forces a portion of that water up the pipe *r*; and it is important that the vacuum formed should be sufficiently perfect to maintain the water in that pipe at a height of thirty feet at least, and if to the full height of a torricellian column of water, so much the better. But it will be evident that the height of this column will vary according to the specific gravity of the

fluid to be raised, and the length of the pipe r , may be made to correspond accordingly.

“ We will suppose the water in the main pipe m, n , to have risen by the internal exhaustion, and the external pressure of the atmospheric air to the height marked by the dotted lines. If a fire be now lighted in the furnace, and raised to a sufficiently high degree of temperature, the water in the main pipe m, n , will become heated, and gradually ascend to q , whence it will flow into the pipes of the condensor or refrigerator; in its passage through those pipes it will be cooled by the current of air which will be passing up the pipe z, z, z , into the box p , and escaping at the pipe u ; and when the water has been thus cooled, it will flow out of the condensor or refrigerator into the pipe r , where it increases the column of water in that pipe to a height greater than the atmospheric pressure below will sustain, and thus a portion of water equal to that which is flowing into the pipe r , at its upper end, is constantly flowing out of it at its lower end, into the cistern s , to restore the equilibrium; and from this cistern s , it is therefore evident a constant fall of water, fifty feet in height from the waste pipe, may be obtained for any purpose required.

“ It may be as well here to observe that the height of the said fall of water will always be determined in an apparatus of this kind by the distance between the surface of the water in the reservoir y , and that in the cistern s . It should also be stated that after a sufficient exhaustion has been made by the air pump to set the apparatus to work, it will still be found necessary to renew the exhaustion by working the air pump, in consequence of the air which disengages itself from the heated water.

“ Now whereas various modes of exhaustion may hereafter be found applicable to my said invention, and various

modes of cooling the water, or other the like fluid, by blasts of air, cold water, or otherwise, as it passes from the upper part of the hot fluid ascending pipe to the upper part of the cooled fluid descending pipe. For instance, I will now describe a mode of cooling with cold water, for which purpose the condensor or refrigerator should be inserted in an open iron cistern, instead of a wooden case, as before described, of a sufficient height for the water therein to cover the upper tier of pipes of the refrigerator. A constant supply of cold water must be introduced into the cistern, while an equal quantity is removed from the same, thereby keeping the water at a reduced temperature.

“ Now in cases where a constant supply of cold water cannot be procured upon a level with the surface of the water in the cistern, without the aid of mechanical means, the mode described in fig. 2, will be found applicable to advantage.

“ A close vessel *a*, (about five feet in length), is fixed to a place where it is always surrounded by cold water, which in this case is the reservoir *y*, being supposed to be constantly supplied with cold water. The pipe *b*, communicates with the vessel *a*, and the cistern *p*. The pipe *c*, communicates with the vessel *a*, and a small cistern *d*, whence it is carried off through the pipe *c*, into the vessel *a*, where it will be sufficiently cooled again, and fit for the use of the refrigerator; and it is evident, that the water will ascend through the pipe *b*, into the cistern *p*, the column of water in the pipe *c*, being higher than the column in the pipe *b*.

“ It will be observed that the pipe *b*, reaches nearly down to the bottom of the vessel *a*, for the purpose of conveying the coldest water to the cistern *p*, the warmest water remaining always at the upper part of the vessel; for the

same reason the mouth of the pipe *c*, which is but little below the surface of the water in the cistern *d*, removes the warmest water from that cistern, and which is equally the case in the cistern *p*, by the suction pipe of *q*, which reaches but little below the surface of the water in the cistern *p*.

“ It will be necessary to fill the vessel *a*, the pipes *b*, and *c*, the cistern *p*, and the cistern *d*, before the apparatus is put to work, and although the same water will be constantly used for cooling the refrigerator, yet it will require from time to time a small addition of fresh water, in consequence of evaporation or other loss of water.

“ And whereas also various modes of applying heat to the ascending fluid may be adopted, but I claim as my invention the combination or manner hereinbefore described, of an air exhausting apparatus, which in this case is supposed to be an air pump; a heating apparatus, which in this case is supposed to be a furnace; a cooling apparatus, which in this case is supposed to be effected by a current of air or water; and a torricellian column, which in this case is supposed to be of water; such combination being for the purpose of raising water or such other fluids as are subject to the same laws, as far as regards the application of the invention thereto, either in order to get rid of or remove the said fluid from the place whence it is taken, or to be applied afterwards as a prime mover.

“ And such my invention being, to the best of my knowledge and belief, entirely new and never before used, &c. &c.”

[*Inrolled in the Inrolment Office in Chancery,
January, 1829.*]

Specification drawn by Mr. Rotch.

The experimental exhibition to which we alluded in the commencement of this report, is considered by M. Bernhard as giving but a very imperfect display of the power which he conceives he has under command by the application of his invention; but that having proved his capability of raising water in an exhausted tube to the height of nearly seventy feet, he conceives that he has shown that the generally received notions respecting the nature of fluids, and their expansion by heat, are not referable to his particular arrangement of apparatus.

The theory which we understand M. Bernhard to have formed is this. Having produced a vacuum in the ascending tube or rising main, the water which is supplied from the canal or a reservoir adjoining, rises in that exhausted tube to the height of about thirty-two feet by atmospheric pressure. The lower part of this column of water is now to be heated, which is done by placing a fire under the boiler, the column of water passing through and forming part of the boiler. By thus applying heat, it is presumed that the water in the rising main becomes *expanded sufficiently to cause it to flow up to the top of the tube, more than thirty feet higher than it was at first raised by the pressure of the atmosphere.* From this height it is intended that the water shall continue to flow, and therefore by the application of these principles, it is considered that water may be raised from mines for draining, or for the supply of elevated situations, or as a prime mover.

That considerable volumes of water were from time to time raised during the experiment to the top of the shaft, (nearly seventy feet) and at intervals discharged therefrom, is certainly the fact; but that it was raised by the expansion of the heated column of water, we must take the liberty of saying is at any rate contrary to all established theory, and inconsistent with all previous experiments

tried upon that subject; and we certainly do not consider it possible that such quantities of water as were discharged could have been produced by the condensation of steam at the top of the shaft. As however M. Bernhard has not set forth any theory in his specification, but insists alone on the fact of being able to raise water and other fluids by means of his apparatus, to a height very considerably greater than has heretofore been attainable by ordinary atmospheric pressure, and conceives that the interrupted flow of the water was caused by the imperfection of his apparatus, which if properly constructed, would produce a continuous stream, we feel it a matter of justice due to Mr. Bernhard, to admit that water has been raised by his apparatus to nearly seventy feet, but upon what principle is for him to point out. We have our own views on the subject, and perhaps when we say that a tube or retort boiler, similar in construction to the refrigerator, was employed, instead of the cylindrical boiler shown in the specification, probably another cause for the water rising and flowing over at intervals may present itself to some of our readers, and the fact may be accounted for upon a different principle to that of the actual expansion of the water.

To THOMAS TYNDALL, of Birmingham, in the county of Warwick, Gentleman, in consequence of a communication made to him by a Foreigner residing abroad, for certain improvements in the Machinery to be employed in making Nails, Brads and Screws.—[Sealed 18th Dec. 1827.]

THE subject of this Patent, like that for making buttons, described in our last at page 126, is the invention of Doctor Church, and communicated by him when abroad to the Patentee, resident in England.

The invention may be considered as consisting of two parts; first, the mode of forming nails or brads, and the shafts of screws, by a process of pinching or pressing heated rods of iron or other metal between indented rollers; and, secondly, an apparatus for producing the threads on the shafts of the screws so previously formed.

SPECIFICATION.

These improvements in the machinery to be employed in making nails, brads and screws consist, in the first instance, of a certain combination of mechanical parts, by which rods of metal, in passing between a pair of rollers, are shaped into the approximate figure of the intended nail, brad or screw, and which, after being so formed, are cut asunder between a pair of shears at the ends of the several intended nails, brads or screws; and these pieces are afterwards further pointed and headed, or otherwise brought to their ultimate figure, by means of dies placed in a rotatory cylinder; which several parts of the mechanism are worked by toothed wheels, cams and levers, as will be fully described and exhibited in the accompanying drawings.

The second part of the invention consists of a new arrangement of mechanism, by which the threads of screws may be cut to any degree of obliquity or form—that is, an original screw may be generated or any description of thread copied by a very simple adjustment of the apparatus, as will be explained hereafter.

In the drawing accompanying this specification, Plate IX, fig. 1, is a horizontal representation of a complete machine, as seen on the top side, for forming the nails, brads or screws in the first instance from rods of metal, and afterwards for pointing and heading the same. Fig. 2, is a vertical view of the end of the said machine, drawn geometrically, the fly

wheel being removed; similar letters of reference denoting corresponding parts of the machine in these and the three following figures; *a, a*, is the main shaft, to which the fly wheel *b*, is affixed. A part of the main shaft is divided into a two-leaved pinion *c, c*, which takes into the peculiarly formed teeth of a cog wheel *d, d*, fixed on the shaft *e, e*, and by means of the rotation of this main shaft all the other parts of the machine are put in action.

Fig. 3, is a vertical section, taken through the machine parallel to the end view, fig. 2, in the situation of the dotted line *A, A*, in fig. 1, in which the forms of the pressing rollers, designed for shaping nails or brads, form the rod of metal, are seen, and also the situation of the dies in the rotatory cylinder for pointing and holding, and the levers for heading the same. It is however to be observed that the rollers and dies exhibited in this figure are designed for forming nails or brads, and would require to be exchanged for rollers and dies slightly differing in shape from these shown, when this machine is to be applied to making the blanks for screws. Fig. 4, is another section, taken vertically, parallel to the preceding, in the situation of the dotted lines *B, B*, in fig. 1. This figure shows the peculiar form of the cogs, or teeth of the wheel *d*, and the two leaves of the pinion *c, c*, taking into the same, which, as the main shaft *a*, revolves, causes the wheel *d*, to be driven, and consequently the other revolutions of the machine to be performed through the agency of the toothed wheels *f*, and *g*; the former of which is fixed on the shaft of the toothed wheel *d*, and the latter on the shaft of the die cylinder *h*; both these toothed wheels being principally shown by dots in this figure.

Rotatory power being applied in the main shaft of the machine, the rod of metal for making the nails is to be introduced through the guides *i*, and passed between the

rollers *k, l*, shown in the section, fig. 3, when the inequalities of the upper roller *k*, will press the rod as it advances into the form of a series of wedges *m, m*, each of which is intended to constitute one nail. The foremost end of the rod being by these means protruded forward, it enters the circular groove of the cylinder *h*, which is situated exactly opposite to it, as shown in fig. 1; and as the cylinder revolves, the partially formed nail passes into the die, as in fig. 3, and is there held while it is cut off; the manner of doing which will be further explained.

The detached figure 5, represents a pair of the dies, as seen on the upper side, upon a larger scale. They consist of two pieces of steel *n*, and *o*, cut with rabbetted ends, suited to the form of the intended nail. These dies are mounted in longitudinal grooves, in the revolving cylinder *h*, as seen in fig. 1, the die *n*, being firmly fixed in the groove and the die *o*, allowed to slide freely. A spring, affixed at the end of the cylinder *h*, acts in a notch, at the end of the sliding die *o*, as seen in fig. 1, drawing it back, and consequently opening the dies. This is the position of the dies, shown in the auxiliary fig. 5; and as the cylinder revolves, the nail introduced into the groove, as above described, passes into the dies at the opening *j*.

The movement of the cutters is effected by means of a cam *r*, affixed to the main shaft *a*, as seen in figs. 1, and 2; and as that shaft revolves, the cam *r*, lifts the lever *s*, attached to the shaft *t*, which causes the shaft *t*, to vibrate on its pivots, and to produce the movement of the upper cutter *q*, through the medium of the short lever *u*.

The short lever *u*, turns on a fulcrum pin in the standard affixed to the frame of the machine, as seen at fig. 3; one end of which lever is connected by a joint to the back part of the vibrating shaft *t*, and the reverse end to the sliding

piece *x*, which holds the upper cutter *q*, the lower cutter being securely fixed to the lower part of the standard. The rising of the lever *s*, causes the piece *x*, and the upper cutter *q*, to descend and to cut off or separate the partially formed nail from the rod.

The partially formed nails being thus cut off from the end of the rod, by the cutter *q*, the cylinder being stationary at the time, the next movement of the cylinder carries this nail up to be headed.

As the cylinder revolves, the end of the sliding die *o*, comes against the curved inclined plane *v*, affixed to the side of the standard, seen in figure 1, which causes the die *o*, to be forced inwards; and by thus closing the dies, the nail is moulded into the required form which it is designed to assume, and at the same time it is held securely for the purpose of being headed.

By raising the lever *s*, in the manner before described, the heading block *w*, attached to the shaft *t*, is depressed, which brings the die *x*, on to the top of the nail, and produces the head.

Let it here be observed, that although the main shaft *a*, is to be turned by a uniform motion, yet in order to give time for cutting and heading the nails, the rollers *k*, *l*, and the cylinder *h*, must be made stationary at intervals; this is effected by the peculiar form of the teeth of the wheel *d*, which allows the levers of the pinions *c*, to move through a portion of their revolution, without driving the wheel forward, and which takes place at the time that one of the cams of the wheel *r*, is raising the lever *s*, and the cutting and heading is performed in the way above described.

The further rotation of the cylinder *h*, carries the nail to the opposite situation to which it was introduced into

the cylinder, where a small punch, acted upon by a spring through the medium of a lever *y*, projects it from the dies, as shown in fig. 3.

The tails of these levers *y*, *y*, extend out at the end of the die cylinder, and are, during the revolution of the cylinder, pressed inwards by a snail formed piece *z*, shown in fig. 2; and when the cylinder arrives at that part of its rotation where the nail is to be projected, the end of the then acting lever slips off the smaller to the large diameter of the snail. The action of these levers will be perfectly understood by reference to the auxiliary fig. 6, which shows the die cylinder in section, taken longitudinally.

Having described the method of forming the rod of metal into wedge-shaped pieces, and cutting those pieces asunder, and afterwards heading them, it will be necessary to observe that the rod of metal should be made hot, previous to its introduction between the rollers; this, however, is not absolutely indispensable, as the nail may be made from the rod in a cold state; but heating it will facilitate the operation.

The form of the dies employed for moulding and heading the nail must depend upon the kind of nail intended to be made; the dies are therefore capable of being removed from the cylinder, and headed with facility; when others may be placed in their stead. "

In moulding the blanks for screws, both of the rollers must be formed with semicircular grooves, and with suitable recesses for the heads; and when cut asunder, the perfecting of the head is performed by the heading die.

I now proceed to describe the second part of the invention; viz. the method and machinery for cutting threads on screws, which are exhibited in the 7th and following figures

of the drawings. The apparatus resembles a turning lathe in some of its prominent features, of which fig. 7, is a horizontal representation; and fig. 8, a vertical view taken longitudinally; *a, a*, is the bed; *b, b*, the mandrel frame, supporting a mandrel, rigger and gearing, resembling an ordinary lathe; *c*, is the foot puppet of the usual construction; *d*, a slide rest, held firmly to the bed by the weight *e*.

A peculiar novel feature in this part of the invention is the method of producing a reciprocating motion of the slide rest carrying the cutter, and which contrivance also affords a means of giving the required obliquity to the thread of the screw.

The wheel *f*, being locked to the rigger *g*, by a peculiarly formed bolt (as will be described hereafter), and the rigger made to revolve in the direction of the arrow, the toothed wheel *h*, and the mandrel *i*, to which it is affixed, will be turned in the opposite direction.

At the back end of the mandrel there is a small pinion *k*, which takes into a rack *l, l*, affixed to a sliding plate *m, m*, shown particularly in the horizontal view. To the plate *m*, a guide box *n, n*, is attached, which turning upon a pin, is capable of being adjusted and fixed at any required angle of obliquity; a bar *o, o*, attached to the slide rest, is connected to the guide bar *n*, by having a notch on the under side, through which the guide bar slides, as seen in the detached fig. 9.

It will now be perceived, that by turning the rigger in the direction of the arrow, the pinion *k*, will cause the rack bar and the sliding plate to recede, that is, to move in the direction of its arrow, and by this movement the guide bar *n*, standing obliquely, will be made to draw the slide rest, by its connection to the bar *o*, towards the mandrel frame. By these means the cutting tool, as it moves with the slide rest towards the puppet head, generates and cuts a screw thread upon the blank *p*, as shown in fig. 8.

When the thread has been cut sufficiently far upon the blank *p*, the action of the machine is reversed for the purpose of car-

rying the slide rest with the cutter back again, by the following means:—As the plate *m*, slides, a tappet *q*, screwed to the plate, strikes against a tooth at the lower end of the perpendicular shaft *r*, shown most evidently in the auxiliary fig. 10, by which means that shaft is turned round, and a horizontal lever *s*, affixed to the top of the said shaft *r*, being connected by a link *t*, to the sliding pin *u*, that pin is forced inwards, and a locking bolt *w*, the arm of which is connected to the pin by passing through a mortice hole, is by the sliding of the pin withdrawn from the wheel *f*, and projected into the wheel *x*; by these means the rigger is now locked to the back train of toothed wheels, as shown in the section, fig. 11; and the mandrel is now made to turn the reverse way.

This movement of the pin is promoted by the logger head above falling over, as shown by the dotted lines in fig. 8. The reverse action being thus obtained, when the slide rest, with the cutter and the sliding plate with its rack has ran back to its extent, another tappet *y*, screwed upon the sliding plate will be brought against the before mentioned tooth at the lower part of the perpendicular shaft *r*, and turn it the reverse way to that above described, which again locks the front wheel *s*, to the rigger.

Previous to the returning movement of the slide rest, it is necessary that the point of the cutter should be withdrawn from the screw; this is done by the action of the before mentioned perpendicular shaft *r*, as will be described. The cutter is attached to the vertical arm of an elbow lever, shown in the auxiliary fig. 12, which lever 1, vibrates upon centres 2, and the rising of the end of the horizontal arm of the lever, causes the cutter 3, to fall back from the screw 4. In the horizontal representation of the machine, shown at fig. 7, there is a sliding bar *z*, attached by a joint to an arm extending from the perpendicular shaft *r*, before mentioned, consequently the action of this shaft is reversing the motion of the slide rest, as described above, causes the bar *z*, to be

slidden to and fro. Upon this bar there are two small tappets 5, 5, capable of being adjusted to any required distance apart, which tappets, as the bar slides, strike against a pallet 6, on the shaft 7. Attached to this shaft there is a small forked lever 8, carrying the pin *q*, which passes through a horizontal slot in the tail of the lever 1. When the cutter is in action, the lever 8, is nearly in a perpendicular position, and is held there by a lever with a logger head 10, seen also in figs. 7 and 8; but on pushing back the bar *x*, for the purpose of withdrawing the cutter from the screw, the tappet 5, strikes the pallet 6, and throws the shaft 7, with the logger head 10, and the forked lever 8, in the opposite position; by means of which the pin 9, sliding in the slot, raises the tail of the lever 1, and throws back the cutter. When the slide rest has moved back to its extent, for the purpose of repeating the cut, the action of the perpendicular shaft *r*, as above described, draws the bar *z*, to the left, when the other tappet 5, strikes the pallet 6, and throwing over the logger head as before, brings the cutter again into action, when it is firmly held by the pin of the forked lever, as explained before.

In order to increase the depth of the cut, a ratchet wheel 11, in figs. 7 and 8, is affixed to the screw of the slide rest, which ratchet wheel coming in contact with a stationary pall 12, at every return of the slide rest, sets up the screw a small portion of a revolution.

To prevent the point of the cutter being broken when it is withdrawn from the work, the tappet on the plate *m*, is made to advance, by very small degrees, at every successive cut, so as to stop the action of the cutter a little earlier every time. The method of doing this is shown in fig. 7, and in the enlarged representation of the tappet fig. 13, the upper plate being removed in this figure to exhibit the parts within.

There is a small lever 13, to which a pall 14, is attached, and this pall is pressed into the ratchet 15, by a spring. Now it will be perceived that by pressing in the tail of the lever 13,

which takes place by its striking again the frame work on every advance of the sliding plate, that the ratchet will be pushed one tooth forward, the tappet by that means becoming elongated, and consequently the distance between that and the other tappet shortened.

This machine is designed for generating and cutting original screws with threads of any required obliquity and figure, and is therefore particularly applicable to the cutting of screw taps, one of which is represented in fig. 8, as under operation; it is also applicable to the cutting of screws for other purposes.

[*Inrolled in the Roll's Chapel Office, June, 1828.*]

Specification drawn by Mr. Newton.

To ROBERT VAZIE, of York-square, in the parish of Saint Pancras, in the county of Middlesex, Civil Engineer, for his invention of improvements in certain processes, utensils, apparatus, machinery, and operations, applicable to the preparing, extracting, and preserving various articles of Food, the component parts of which utensils, apparatus and machinery are of different dimensions proportionate to the different uses in which they are employed, and may be separately applied in preparing, extracting, and preserving Food, and in other useful purposes.—[Sealed 12th July, 1827.]

THE subjects comprehended under this Patent form rather a singular association. They are, it is true, all designed for the preservation and preparation of food; but we do not remember to have ever before met with such a combination of subjects as an improved wheat stack, a thrashing machine, a corn mill, and a steam kettle, all within the

pale of one Patent right. Such however appears to be the case by the specification before us, in which the Patentee divides his invention into four heads; first, a "Corn Preserver," which is an improved method of stacking wheat; second, a "Corn Extractor," a thrashing machine; third, a "Conical Corn Mill," a portable steel mill; and, fourthly, a "Steam Stove," or rather a steam kettle. The Patentee describes them as follows:—

SPECIFICATION.

The Corn Preserver.—See Plate X, fig. 8.

"A stake of proportionate length to the height of the sheaves of corn or pulse to be preserved, is pointed at each end; the thicker end is driven into the ground about six inches (as shown by dots;) there is then placed around the stake eight sheaves of the usual size, more or less. A hood sheaf of nearly double the dimensions of the upright sheaves, is bound tight near to the straw end of the sheaf; it is then inverted, placed on the stake by which it is supported, and spread around the upper part of the upright sheaves; in this state the corn may remain until it is sufficiently dry to be stacked or housed.

"This improvement, in which every individual in the country is interested, consists in preventing the injury which corn and pulse too frequently sustain by rain and wind during harvest.

The Corn Extractor.—This machine is shown in the side view, fig. 9.

"A frame of wood *a, a*, is formed four feet six inches in length and three feet six inches in breadth (inside measure,) by three feet six inches in height. A plate *b*, three feet six inches in length by two feet in depth, in the form of a segment of a circle, is placed within the frame in a proper position, to correspond with the action of a

skeleton wheel *c*, which is gently turned round by manual labour within the concave of the said plate; this wheel *c*, is three feet five inches in length by three feet in diameter, the arms *d*, of the wheel stand obliquely, yet parallel to each other.

“ At the distance of twelve inches behind this wheel, there is placed a frame *e*, to support another wheel *f*, of twenty inches in diameter; upon this wheel a sheaf of corn *g*, is suspended by the straw end, during the operation of extracting the corn therefrom.

“ The advantages attending this process are reduction of manual labour, and preserving the straw uninjured; and in extracting the grain without bruising it, which in the cases of seed and corn to be stored, is a valuable consideration.

The Conical Corn Mill.—See fig. 10.

“ A frame of metal *a, a*, is formed thirteen inches square, inside measure, by three feet six inches in height, with a bottom frame to rest upon; within the upper rail of this frame there is placed a hollow cone of steel or other metal *b*, twelve inches diameter at the top, and one inch diameter at the bottom, inside measure, by nine inches in depth; within this cone there is placed an interior cone *c*, of like metal: these cones are grooved transversely from each other. In the centre of the top of the interior cone there is fixed a spindle *d*, whereby the cone is turned round through the medium of cog wheels, by a handle attached thereto.

“ The whole of the above dimensions may be more or less, as circumstances shall require. The improvement in this case consists in a reduction of manual labour, and in preserving the meal and flour from being heated during the process.

“ These cones may be enlarged to require the aid of horses, water, or steam.

The Steam Stove.—See the section of the kettle, fig. 11.

“ There is formed a boiler of iron or other metal, of any required form or size, in which there is placed a vessel or stove *a a*, of silver plate or tin, suspended in such a manner as to leave room for the extra steam generated in the boiler *b*, to pass into the upper chamber or space *c*, betwixt the cover of the boiler and the cover of the stove. The process is performed by placing on the fire the boiler containing as much clear water as will rise to about one third part of its height; the stove is then inserted, into which there is put the required quantity of meat cut into slices, with onions, rice, seasonings, bread, and as much cold water as will cover those articles; the stove and boiler are then closed, and the operation commences. In the course of half an hour the water in the exterior vessel will boil, and speedily afterwards the stove will acquire the due heat for preparing animal food, *which it never exceeds.*

“ This is the desideratum which the faculty have, with great honour to themselves, frequently attempted to obtain, but heretofore without success. The scum must be removed as it rises. At the expiration of an hour and a half the process will be completed, if the heat in the boiler has been properly supported.

“ A good proportion for a stew is one pound of rump steak, and one pound of a leg of mutton cut into slices; put these in the stove, and place thereon two full-grown onions shred small, two table spoonfuls of rice, one dessert spoonful of salt, and one tea spoonful of pepper, together with a slice of bread and the quantity of cold water stated above. This dish I designate an English Stew.

“ Joints of meat, fowls, fish, potatoes, or other vegetables, require to be covered with water during the process; steaks may be dressed in butter or other oily substance, and confectionary with sugar. When the operation is performed in an oven, there will be required a cover on the stove, but none on the boiler.”

The advantages resulting from this application of heat are as follow :—

First.—The flavour of the food is rendered peculiarly grateful, by the meat being prevented from resting on the bottom of the boiler, which occasions an acrid nauseous taste, and impedes digestion.

Second.—The extra steam passing into the upper chamber, prevents the stove from being charged with more heat than is necessary for the due preparation of the food, accelerates the heat in the stove, and renders the preservation of the juices or essence of animal substances complete: the surplus quantity of that nutritious fluid being infused into the rice and bread contained in the stove, renders them in a great measure as restorative as the meat itself, and thus converts those otherwise passive articles into valuable economical substitutes; even a moderate quantity of meat, with a large portion of potatoes, produces very nourishing food for persons of restricted incomes.

Third.—Any kind of meat usually boiled may be prepared by this process for immediate consumption, or as provisions for a distant voyage, having regard that the lean part of fresh meat is the most nutritious and of the best flavour. By this progress there is a saving of twenty-five per cent. in the consumption of animal food; but even that saving is of small import compared with the invigorating and healthful effect the human frame derives from a full supply of the juice of animals produced in a state of great perfection.

In dressing potatoes alone, unpareé, in this stove, the saccharine quality of that valuable root is entirely retained.

Fourth.—This apparatus is preserved in good condition with little labour, and is very durable; the process is *free from danger*; it is simple, pure, and will prove serviceable to persons of all ranks in society; in the mess of regiments, in the navy, in merchant vessels, in hospitals, and in other large establishments.—[*Inrolled in the Petty Bag Office, Jan. 1828.*]

To ANTON BERNHARD, of Finsbury Circus, in the county of Middlesex, Engineer, for his having invented certain improvements on or additions to wheels on apparatus for propelling Vessels, and other purposes.—[Sealed 15th Dec. 1828.]

In the application of this invention the Patentee has adopted that kind of paddle wheel which is constructed with ordinary rectangular float boards or paddles, but suspended upon crank axles, for the purpose of enabling them to turn over, in order that the paddles may enter into the water edgewise, and quit it in the same way, preserving their perpendicular positions during the time of giving the propelling stroke. Paddle wheels upon this sort of construction, that is having their floats suspended upon crank axles, may be seen in several instances in the previous volumes of our Journal, as in Lambert's Specification, Vol. I, First Series, page 341—Oldham's Specification, Vol. XIV, page 1. The particular feature of improvement, however, claimed under this Patent is a contrivance by which the paddles may be made to assume any desired position from the perpendicular, to the horizontal, and to preserve the same

positions during the rotation of the wheel, which the Patentee considers will afford very considerable advantages over any other paddle wheel at present in use, as by changing the positions of the paddles, he will be enabled to take advantage of currents, or under some circumstances, to throw the paddles altogether out of operation, which may be desirable when sailing.

SPECIFICATION.

“ I, the said Anton Bernhard, do hereby declare the nature of my said invention to consist in a guide or leading frame, to which each paddle is connected by a crank, and which gives the paddles a direction independent of that which they would otherwise receive from the frame which carries them round; and also in a mode of varying at pleasure the said direction so given as aforesaid.

“ Plate X, fig. 1, is a side elevation of a paddle wheel furnished with my said invention; the parts marked *p*, represent eight paddles turning on axes at their centres, and which axes rest on bearings in the frames *f, f*, one only of which can be seen in this figure, but which are in fact the frames which carry the paddles round on the main axis *a*; the parts marked *g*, form together a separate frame, which I call the guide or leading frame, revolving also round the main axis *a*, but upon a different centre, which different centre is obtained by means of the eccentric *e*, placed on the main axis *a*; the parts marked *c*, are small cranks firmly fastened at one end to arbors on the ends of the axes of the paddles, and at the other end to the arms of the frame *g*, by means of crank pins, which turn in bearings marked *r*, placed to receive them; *e*, is a circular plate acting as an excentric, and which I therefore call such.— It rests in a steady plate *i*, and the main axis *a*, passes loosely through it. This excentric may be turned round when necessary, but is held steady to the position required when the paddles are in motion, by means of a lever or arm, not shown on the side of the eccentric exhibited in this figure, lest it should

confuse the drawing, but shown at *l*, as fastened to and projecting from the eccentric at the opposite side of the wheel.

“ The effect of the guide or leading frame *g*, moving round the eccentric *e*, while the eccentric is held in the position here shown by means of the lever *l*, is to preserve by the action of the cranks *c*, the vertical position of the paddles during the whole revolution of the frame *f*, to which they are attached. But it is obvious that if the lever *l*, be raised or depressed, the eccentric will turn round in the steady plate, and draw with it to one side or other the guide or leading frame *g*, (as shown by dots), causing a corresponding movement in the cranks *c*, that will force them out of the vertical position here shown, and cause them to take any angle required, which angle they will preserve, when the lever *l*, is fixed again with the same uniformity during the revolutions of the frame *f*, that was attributed to the vertical position before described ; *b*, is the plummer block, and *d*, the beam to support the main axis *a*, of the paddle wheel.

“ Fig. 2, is drawn merely for the purpose of more clearly explaining the relative position of the main axle, which carries round the paddle frame and paddles, and the guide or leading frame, which is acted upon by the cranks ; part of this figure is shown in section and part as an elevation, as was thought best for explanation, and only two paddles are represented, lest a greater number should make the drawing confused.

“ It will be seen that the apparatus, the side elevation of which is shown in fig. 1, is to be repeated at the opposite side of the machine ; but where no great strength is required, it is obvious that one guide or leading frame, and crank at one side of the paddle wheel, will suffice.

“ In figure 2, now under description, *a*, is the main axle or shaft ; *f, f, f, f*, are two arms of the frame which carries the paddles *p, p*, the paddles turning on axes which work in the bearings *s, t*, placed on the ends of the arms, *f, f, f, f*, to receive them.

“ I have only described such parts of a paddle wheel as have already been used ; but I will now proceed to describe the additions thereto, which constitute my said improvements ;— they consist of the guide or leading frame g, g, g, g , turning round the eccentric e , and of the levers l, l , which turn the eccentric. It will be seen that the arms of the guide or leading frame g, g, g, g , are connected with the axes of the paddles by means of the cranks c, c, c, c ; and it should be here stated, that the length of the cranks c , from the centre of the crank pin to the centre of the paddle axle, should correspond exactly with the distance from the centre of the main axis a , to the centre of the guide or leading frame ; the two levers are one fastened to each eccentric, and connected at their upper ends by a cross bar, for the purpose of turning the eccentric, and thereby giving any required position to the paddles.

“ Now the effect of this arrangement will be, that as the main axis or shaft a , is driven round by the steam, or other power applied to it for that purpose, it will of course carry round with it the frame f, f, f, f ; and the paddles p, p ; at the same time that the paddles, by means of the cranks c, c, c, c , on their axes, will drag round the guide frame g, g, g, g , which guide frame turning on the eccentric e , and thus having a different centre of motion to the main axis a , will cause the paddles to turn on their axes as the frame to which they are attached passes round in such manner as to preserve the vertical position of the paddle through the whole course of its revolution. I state here *vertical position*, because in this figure the levers l, l , are supposed to be fixed in the same position as shown, but as stated before ; the object of the guide or leading frame, eccentric and cranks, is to preserve the paddles in whatever position may be required, such position to be determined by the position of the eccentric in the steady plate, and of the paddles on their respective axes.

“ Figures 4, and 5, are two separate views of the eccentric e , and its lever l ; it will be seen that there is a boss v ,

cast on the eccentric, which fits into the steady plate *i*, in which it turns; and there is a groove in the boss, to receive two half rings, which keep the eccentric steady in the steady plate.

“ Now whereas I claim as my invention, first, the guide or leading frame marked *g*, attached to the cranks marked *c*, and turning round the eccentric marked *e*, for the purpose aforesaid; and, secondly, the lever marked *l*, attached to the said eccentric, for the purpose of giving any required angle to the paddles at pleasure.

“ And whereas such my invention is, to the best of my knowledge and belief, entirely new, and has never before been used, &c. &c.”—[*Inrolled June, 1829.*]

Specification drawn by Mr. Rotch.

To DAVID REDMUND, of Greek-street, Soho, in the county of Middlesex, Engineer, for his invention of certain improvements in the construction and manufacture of Hinges.—[*Sealed December 22, 1826.*]

THIS invention is to be considered as an improvement on a former Patent, granted to Mr. Redmund in 1821, the particulars of which are given in the First Series of our Journal, Vol. V, page 178. In that instance the Patentee contrived a hinge, one half of which was made to rise by the cylindrical part being divided in the middle by inclined planes, and which enabled the door to close by its own gravity, but by means of two flat parts upon the planes, the door might be set open and remain so.

The great superiority of these rising hinges over others, designed for the same purpose, has brought them into very general use, and the object in the present instance is to render the same description of articles more effective

and more elegant than its appearance than the hinges on the plan of the former Patent were capable of being made.

There are two points of novelty proposed;—the first is to adapt a spring to the hinge, by which the door would be made to close with greater force than its own gravity would be capable of effecting; and, secondly, the operative parts are all enclosed so as to conceal them from view.

Plate X, fig. 12, shows the improved hinge, the barrel part being in section, for the purpose of exhibiting the interior; *a*, and *b*, are the two wings of the hinge, which are respectively connected to the upper and lower parts of the barrel *c*, *d*. The middle joint of the barrel is an inclined plane, and the upper portion *c*, carrying the wing *a*, turns upon a pin fixed in the lower part of the barrel, and there is a corresponding recess in the upper part, which is shown by dots in the figure.

Around the middle part of the barrel of the hinge, there is a ferrule or socket *e*, *e*, which covers the joint, and this ferrule being fixed to the wing *b*, remains stationary, and conceals the opening in the middle of the barrel, which would otherwise be visible when the wing *a*, rises. Thus the appearance of the hinge is rendered more neat and elegant than in its former construction.

The upper and lower parts of the barrel are both made hollow, and contain each a spiral spring coiled round a rod, which spring being made fast at one end to the rod, and at the other end to the barrel, becomes drawn up to tension by the opening of the door, and hence by the exertion of the force of the spring the door is closed again when left at liberty. The end pieces are inserted into the barrel by screwing, and may be of any figure or form that taste shall dictate.—[*Inrolled June, 1827.*]

Ta CHARLES HARSLEBEN, of Great Ormond-street, Queen-square, in the county of Middlesex, Esq. for his invention of certain improvements in constructing or building Ships and other Vessels, applicable to various useful purposes, and in machinery for propelling the same.—

[Sealed 20th Dec. 1826.]

THERE are three distinct subjects embraced in this Patent; the first is an improved mode of constructing such vessels as are intended to be employed in the conveyance of fish, by which improvement that description of vessels will be enabled to be employed at times on other business, and may be propelled by machinery, instead of depending entirely upon the wind as heretofore; secondly, in an improved apparatus or system of paddles for propelling the same or any other description of vessels on water, by the power of steam, or any other first mover; and, thirdly, an improved apparatus for towing vessels against the current of a rapid stream of water.

As respects the first part of this invention, the mode of constructing vessels designed to convey fish, it is stated that it has been the practice to make wells or large receptacles in such ships for containing the fish, which being filled with water, allowed of the fish being conveyed alive to the port, market, or other place of destination. But these wells occupying a very large portion of the vessel, and the fisheries only requiring such vessels for a season, the greater part of the year they were altogether unemployed, and from the peculiarity of their construction, they were totally unfit for the conveyance of dry goods, or for any other business, which is a considerable loss to the proprietor, and a detriment to the vessel itself.

To remedy this inconvenience, and to render vessels designed for the conveyance of fish capable of being converted to other uses, the Patentee proposes to construct the wells in such vessels with water tight partitions, dividing them into several compartments, the different wells or compartments communicating with each other by means of cocks and sluices, so that certain portions may be emptied in bad weather by pumping out the water; and if occasion should require, at certain seasons, parts or the whole may be kept dry for the stowage of goods of any description, and the vessel then rendered fit for general use.

The partitions separating the wells are to be made thick, and to contain air vessels between them, by which means the ship will be rendered buoyant, even if she were filled with water. It is further proposed to propel such vessels by steam power, and with the following improved paddles:—

Instead of the ordinary paddle wheels, it is proposed to employ a series of rotatory oars, on each side of the vessel, mounted on perpendicular shafts, which oars are intended to traverse through the water in circles horizontally, and to turn over for the purpose of feathering, that is, performing the return stroke edgewise.

Plate X, fig. 5, represents the section of a flat bottomed vessel, with a set of the rotatory oars on each side; *a, a,* are two of the oars, which are in their propelling positions; *b, b,* are the corresponding oars, seen edgewise, performing the returning stroke. There are four oars attached to the end of the horizontal cross shafts, the faces of the opposite ones standing at right angles to each other. These horizontal shafts are mounted in plummer boxes in the lower part of the vertical shaft *c, c,*

and are enabled to turn round freely therein. The vertical shafts are mounted in and pass through the tubes *d, d*, shown in section, which are attached to the sides of the vessel by bracket arms *e, e*.

Any rotatory power, as that of a steam engine, being applied to the upper parts of the vertical shafts *c, c*, they will be made to turn, and to carry the horizontal paddle shafts round with them; (in the figure only two of the paddles are shown.) Those paddles, which are moving on the outer side, will perform that half of their horizontal revolution, with their broad faces acting against the water in the positions shown at *a, a*, which is giving the propelling stroke; and the paddle at the opposite end of each shaft, will pass through the inner half of its circuit, which is the back stroke edgewise cutting the water.

The mode by which the paddles are made to turn over, is by the tappets *f, f*, on the paddle arms, striking against an elongated part of the tube *d*, at *g*, which as the horizontal shafts go round, turn them over, and cause each paddle successively to fall into the positions shown at *a*, and *b*; the outer ones into the propelling position, the inner ones edgewise.

Any number of these sets of paddles may be placed along the vessel's sides, for the purpose of acting simultaneously, which may be put into operation in the way described, by connecting the upper parts of all the perpendicular shafts to the steam engine, or other actuating power, by which the oars or paddles will be made to revolve, and to row the vessel forward.

The section, fig. 5, represents a flat bottomed boat, with a false keel *h*; and if it should be desirable to employ paddle arms of a greater length than half the width of the vessel, it is proposed to cut away the false keel, in order to

let the paddles pass; and for the convenience of allowing the paddles to be repaired, the bracket arms *a*, are made to rise upon hinge joints.

As it may be desirable, under some circumstances, to propel vessels which are built with very sharp bottoms, fig. 6, represents a mode of placing the above described paddles in oblique directions, which may be made to revolve by any convenient mode of connecting the driving power to the paddle shaft.

Towing vessels up rivers or channels, in which there are very strong currents, is proposed to be done by the employment of a cross armed fan, with leaves or shutters, something like a horizontal windmill, which being mounted on a perpendicular shaft, is to be immersed entirely below the surface of the water; and the current being partly shut off by partitions in the fan case, the current is made to act against one half of the fan, only for the purpose of driving it round and giving the power to its shaft, which as a windlass coils up the towing rope attached to a vessel, and brings the vessel up against the stream.

Fig. 7, is a horizontal view of the fan *a*, with four arms placed at right angles. From the perpendicular frames connected to each of these arms, a series of flaps are suspended, which rise and fall upon hinge joints; *b*, and *c*, are two partitions affixed to the box or case, in which the rotatory fan is mounted. These partitions are so disposed that the current of the stream will only be allowed to act upon two of the fans at a time; the other two being shielded. Hence the force of the water bearing against the flaps of the fan, and these being stopped, by striking against the frame, cause the fan to be driven round; and the flaps on the opposite arms of the fan at the same time rising upon their hinges, and floating, pass through the water edgewise with little, if any resistance.

The power thus obtained being, as before said, applied to the shaft which is to act as a windlass, the towing rope attached thereto, draws a vessel through the stream, contrary to the course of the current.

As this fan and its case must be of very considerable dimensions, and may require to be occasionally shifted from place to place, in order to station it in the most favourable part of the current, it is proposed to construct it on a platform on the top of an air tight vessel as a caisson, which when required to be moved, may be filled with air, and then floated to its intended place of destination. When about to be fixed, the water must be let into the air vessel, and the top of it covered with large stones or other heavy bodies, as ballast, in order to keep it stationary and firm in its position; and when about to be moved, the ballast must of course be removed, and air pumped into the caisson, for the purpose of displacing the water occupying the vessel.

The rotatory fan having been applied to a similar purpose before, the Patentee limits his invention, as respects the towing apparatus, to the partitions *b*, and *c*, which shut off and guide the current of the water.—[*Inrolled June, 1827*]

To THOMAS LAWES, of the Strand, in the county of Middlesex, Lace Manufacturer, for his invention of an improvement in the manufacture of Bobbin Net Lace.—[Sealed 10th Dec, 1828.]

THE invention specified and claimed under this Patent is confined to the manufacturing of bobbin net lace with single threads, instead of doubled threads as generally used.

The Patentee proposes to emerse the threads in size made from flour, gum, or glue, but he prefers glue; and

as the threads are wound from one bobbin to another, to pass the threads through the thumb and finger of the operator, to remove all superfluous size.

By the employment of these single threads, a kind of lace may be made, which will be much thinner and cleaner in its appearance than the lace of the ordinary kind.—
[*Inrolled June, 1829.*]

Polytechnich and Scientific Intelligence.

AMERICAN PATENTS.

For a thrashing machine; Matthew Barney, Nantucket, Mass.
August 5.

THIS machine is, in form, something like the common horse gin. There is an upright shaft, with a bar projecting out, to which the horse that turns it is attached. Three arms, eighteen feet long, and fourteen inches wide, are passed through mortices, so as to form six radii from the centre of the shaft: these are connected together by six pieces of plank, each passing from the lower edge of one arm, to the upper edge of the next arm, and, consequently, forming six inclined planes. Eight flails, or thrashers, eleven feet long, work side by side, upon one common pin; their short ends, three feet in length, pass under the wheel, and are tripped by it as it passes round; the whole making 48 strokes in each revolution.

The grain is placed upon a table standing under the outer ends of the thrashers; this table traverses backwards and forwards, by means of a windlass. The patentee says, "by placing flax or hemp on said table, I believe it will break it equal, if not better, than any other way."

For a method of casting moveable Printer's Types ; whereby the process is rendered practicable by mechanical means, and its expense much abridged ; Wm. M. Johnson, New York, Aug. 21.

The description of the apparatus and process, which form the subject of this patent, is of great length, occupying upwards of thirty closely written pages ; besides which, there are about twenty well delineated figures, with seven pages of descriptive reference. The concluding part, in which the Patentee states his claims, will afford a pretty full and clear idea of the nature of the invention.

“ The improvements which I claim by right of original invention are—

“ 1st. The giving to the mould, by the turning of a crank, all the motions that are requisite in it in casting, viz. the opening and shutting the mould with proper force and accuracy ; the raising of the matrix, and the discharging of the type ; said operations of the mould being performed by means of the mechanism above described, or by any other that merely varies the form, without improving the process.

“ 2dly. The performance of all the motions of the kettle apparatus, by the turning of a crank, viz. the producing and stopping of the metal through an aperture in the kettle, and giving it the needful force ; this operation being performed by means of the mechanism herein described, or by any other that merely varies the form, without improving the process ; not intending to embrace within this claim, the use of a stopper alone, or a plunger alone, but the use of the two together, when worked by a crank.

“ 3dly. The use of a moveable cover, to the cavity of the mould, by means of a distinct piece coming between the kettle and the mould, to prevent the metal from over-running it when forced into the mould ; this appendage being applied in the manner afore stated, or in any other

that merely varies the form without improving the process.

“ 4thly. The covering and uncovering the cavity of the mould (with the said cap or cover), by the turning of a crank; this action being effected by means of the mechanism afore described, or by any other that only varies the form without improving the process.

“ 5thly. The application of water to the mould, by a rapid dropping, or constant stream upon it, whilst casting, when worked by a crank, as afore described; and also the application of water to the cap, by the means above stated, or by any other that merely varies without improving the mode; it is not intended in the claim, to embrace the use of water to the mould in all shapes, but merely its use by a *constant passage* of it when applied to one side of the mould alone, and when applied to the cap, or to the two sides of the mould together, by any kind of a stream or passage of it, or by any means that merely varies without improving the mode.

“ 6thly. The combined use of the plunger with valves, and a stopper rod, in a stationary kettle, that has the fire around it; said plunger and stopper being attached to the kettle in the manner afore stated, or in any other, &c.

“ 7thly. The use of compressed atmospheric, or other air upon the surface of the melted metal, to give it the needful impetus into the mould, said power being applied in the manner herein described, or by any other &c.

“ 8thly. The combined action of the mould, cap, stationary kettle, plunger, and stopper, or air pressure, in lieu of plunger and water, by means of a crank as afore specified, or by any other, &c. It is intended, in this particular claim, to embrace only the *combination* of the several parts, as affording, in their united operation, a new process, and a certain degree of improvement.

“ 9thly. The removing the mould from the kettle, in order to discharge the type by causing an immediate separation between the two, by taking the mould off from the kettle in a line with the direction of the stream of metal that is injected into the mould, or at any angle with that line, without having any sliding upon the surface of the kettle, or other friction against it, further than that produced by the taper point of the spout, in contact with the hole of the cap.”

For an improved machine for washing all kinds of wearing apparel, &c. ; Jonathan R. Davis, Hartland, Niagara county, New York, Sept. 4.

This machine has a wash-board, very similar to that which has been so extensively used in this country, having grooves across it, upon which the clothes are rubbed by hand, instead of being rubbed between the hands. The present patentee adds a grooved roller, which is to be fixed in a suitable frame ; the clothes, &c. to be washed, are laid upon the grooved board, where they may be kept moistened with soap-suds, and the grooved roller is passed backward and forward over them, the frame in which it revolves being held in, and guided by, the hand ; there are, also, grooved guides on the frame, which work on projecting strips on the edge of the wash-board, to retain the roller and frame in their places.

For an improvement in the machine for washing cloths ; Joseph Hathaway and Rufus Hathaway : the former of Pultney, Steuben county ; the latter of Canandaigua, Ontario county, New York, September 5.

This machine consists of two hollow cylinders. The outside cylinder is fixed in a suitable frame, its axis being

horizontal. This cylinder is made water-tight, and is divided into two parts, the lower half forming a trough, and the upper half a cover or lid. Within this cylinder, another is made to revolve, by means of a crank and gudgeons. The circumference of the inner cylinder, is formed by slats, dove-tailed into the circular ends, and standing about three quarters of an inch apart. Into this, the cloth to be washed is put, there being a door for that purpose. The slats are sloped on the sides in reversed directions, so that when the inner cylinder is turned either way by the crank, the water shall have a tendency to flow from the outer into the inner cylinder. The motion proposed to be given, is a vibratory one, by turning the crank each way, about half a revolution. On two opposite slats, pins are placed, pointing towards the centre of the cylinder; these are intended to change the position of the cloth to be washed. The frame is to be kept together, and tightened, by iron rods, with heads, screws, and nuts.

This machine, in its general features, bears a strong resemblance to others which have been heretofore used; the patentees say, "what we claim as new, and as our own invention, in the above described machine, is the operation of the open cylinder, and the manner of fixing in those slanting slats, to carry the water to every part of the machine, to serve as drenchers; also the iron rods that fasten the frame together."

For a socket vice. Granted to Luther Hemminway, of Sullivan, Cheshire county, New Hampshire, September 4, 1828.

The socket vice may be made of any size, according to the use to which it is to be applied, and of metal or wood. When made to be used as a socket for awls, it should be

of steel ; its whole length should be about two inches and three fourths ; one end, for about three fourths of an inch, should be round, and about one fourth of an inch in diameter ; beginning three eighths of an inch from the end, it should taper slightly to the end, upon which, for the same distance, a screw should be cut ; it should then diminish, and again increase in diameter, in both cases slightly, and gradually ; at three fourths of an inch from the end it is flattened abruptly, forming a shoulder on two sides, and is made tapering on the two edges, to the other end, where it is pointed ; a hole is made longitudinally into the round end, about three fourths of an inch deep ; it is then cut twice transversely from the end to the bottom of the hole, dividing it into four equal parts ; a hollow screw or nut, adapted to the vice, is screwed upon this end, compressing it so as to hold firmly the shank of the awl ; the outside shape of the nut should be square, so that it may, by means of a small wrench, be easily screwed on or off. The pointed end of the socket vice may be inserted in a block of wood, so far as to the commencement of the screw. When made for other uses, the size and the form of the shank may be varied, to suit such uses.

SOCIETY OF ARTS.

Our last notice of this Society in Vol. II, page 346, contained an account of the commencement of Mr. Aikin's Lectures, delivered before the members and their friends on Tuesday evenings. It was our intention to have continued reporting the whole of these lectures at considerable length ; but although the subjects were arranged with considerable ability, and written with neatness and perspicuity, yet there appeared to be little or no features of novelty developed, and the principal matters for admira-

tion were the superb specimens of art which were lent to the society for the occasions, by the members and their friends. We therefore relinquished our purpose, conceiving that a mere catalogue of rare and curious articles would have afforded neither information or amusement to our readers.

The Society have now discontinued their meetings for the present sessions, having distributed their rewards, both honorary and pecuniary, among the successful candidates for their approbation.

The presentation of medals adjudged in the class of Polite Arts took place first, when His Royal Highness the Duke of Sussex presided in the Society's Great Room, and with many complimentary observations, bestowed the various medals of gold and silver upon the juvenile artists, as stimulants to future exertions.

On a subsequent day, the productions which may be denominated scientific, were rewarded by the President in the same place in the following order:—

Mr. J. Vendramini, 14, Brompton Row, from his engraving from the picture by Sebastian del Piombo of the Raising of Lazarus—the large Gold Medal.

Mr. J. Robertson, Worton House, Isleworth, for his improvements in the art of painting in water-colours—the Gold Isis Medal.

Mr. Joseph Netherclift, 8, Newman Street, for his improved method of making lithographic transfers—Twenty Pounds.

Thomas Dowler, M.D. for his musical instrument called the glossophone—the large Silver Medal.

Mr. J. Cuthbert, 5, Purbeck Place, Lambeth, for his stand for an astronomical telescope—the large Silver Medal and Twenty Pounds.

Mr. W. H. Hilton, 10, Regent Street, for his pump for racking wine—the large Silver Medal.

Mr. R. Parvin, 3, Carpenter Street, Mount Street, for his improved French window—the Silver Isis Medal and Five Pounds.

Mr. W. Tindall, Leeds, for his wheel with an oblique axle—the Silver Isis Medal.

Mr. W. Aust, Hoxton New Town, for a copper lining to a leaden pump-barrel—Five Pounds.

Mr. T. Williams, Lieut. R.N. for his oars to be worked by one hand—the large Silver Medal.

Mr. W. P. Green, Lieut. R.N. for his yoke for a disabled rudder—the Silver Isis Medal.

Mr. W. Rodger, Lieut. R.N. for his syphon for watering ships—the Gold Isis Medal.

Ditto, for his make-shift anchor—the large Silver Medal.

Mr. Edward Carey, R.N. for his method of preventing dry rot in ship timber—the large Silver Medal.

Mr. T. Reynolds, 13, Arbour Terrace, Commercial Road, for his repeating stop for a naval sextant—the Gold Isis Medal.

Mr. D. Davies, 15, Wigmore Street, for a fire-escape—the large Silver Medal.

Mr. S. Mordan, 22, Castle Street, Finsbury, for his self-centering lathe-chuck—the large Silver Medal.

Mr. Joseph Clement, 19, Prospect Place, St. George's, Southwark, for his self-acting double driver for a lathe-chuck—the large Silver Medal.

Mr. James Roberts, 7, Abbey Street, Bethnal Green Road, for his improvements in weaving velvet—Five Pounds.

Mr. J. Hughes, 93, Sebright Street, Bethnal Green, for

his improved cards for weaving figured silks—the Silver Isis Medal and Fifteen Pounds.

Mr. C. S. Smith, 3, Kirkman's Place, Tottenham Court Road, for his method of manufacturing melting pots for iron and steel—Twenty Pounds.

Mr. R. Green, 57, Ernest Street, Regent's Park, for his draining plough—Fifteen Pounds.

Mr. J. Pearson, Frittenden, Kent, for his draining plough—the large Silver Medal and Fifteen Pounds.

Joseph Kirby Trimmer, Esq. Strand on the Green, Kew, for his flock of improved Merino sheep—the large Gold Medal.

Josias Booker, Esq. Liverpool, for his substitution of machinery in aid of slave labour—the large Gold Medal.

DIORAMA.

THE conductors of this delightful and fashionable exhibition have presented the public with two new pictures—a view of the little town of Thiers, in the province of Auvergne in France, and the interior of the church of St. Peter's at Rome.

In the execution of the first of these pictures the artist has displayed a degree of talent certainly not surpassed, if equalled, in the finest productions of former exhibitions.

The scene is of limited extent, and though in the neighbourhood of a town, appears to be a peaceful seclusion. The haziness of morning almost conceals the peeping tops of distant hills, and the only animated object seen is a miller quietly seated by his door, inhaling the morning breeze. Near the foreground the mill stream flows with

glassy smoothness, and partially breaking through its rugged banks presents a moving silvery foam, the very semblance of nature.

Turning to the picture of St. Peter's, we are not able to speak with equal commendation. This colossal structure, though magnificent in its design, is gaudy in its decorations; and the association of colours and gilding detract greatly from the sublimity of the scene. The artist is in this respect unfortunate in the selection of his subject; but that is not all—the picture, (certainly a difficult one to execute) falls considerably short in effect, particularly in the prominent parts of the sculpture, which are not brought out with that delicacy of touch so peculiarly necessary in representing the soft relief of marble.

New Patents Sealed in 1829.

To Maxwell Dick, of the town of Irvine, in the county of Air, North Britain, bookseller and publisher, for his having invented an improved rail road, and method of propelling carriages thereon by machinery, for the purpose of conveying passengers, letters, intelligence, packets, and other goods, with great velocity. 21st May—6 months.

To Thomas Robinson Williams, of Norfolk Street, Strand, in the county of Middlesex, Esq. for his having invented improvements in the making or manufacturing of felt, or a substance in the nature thereof, applicable to covering the bottoms of vessels, and other purposes. 23d May—6 months.

To Thomas Arnold, of Hoxton, in the county of Middlesex, tin plate worker, for his invention of a new or improved machine or gauge, for the purpose of denoting the quality or strength of certain fluids or spirituous liquors, and for measuring or denoting the quantity of fluids or spirituous liquors, withdrawn from the vessel or receptacle in which the same are contained, and which machine or gauge may be so constructed as to effect

either of the above objects without the other, if required.
26th May—6 months.

To William Poole, of the parish of Saint Michael on the Mount, in the City of Lincoln, smith, for his having invented certain improvements in machinery for propelling vessels, and giving motion to mills and other machinery. 26th May—2 months.

To Charles Turner Sturtevant, of Hackney, in the county of Middlesex, soap boiler, for his having invented certain improvements in the process of manufacturing soap. 26th May—6 months.

To Joseph Clisild Daniell, of Limpley Stoke, in the parish of Bradford, in the county of Wilts, clothier, for his invention of certain improvements in machinery, applicable to the dressing of woollen cloth. 26th May—6 months.

To Ross Winaus, of Vernon, in the county of Sussex, and State of New Jersey, in the United States of North America, at this time resident in London, for his having invented certain improvements in diminishing friction in wheeled carriages, to be used on rail and other roads, and which improvements are applicable to other purposes. 28th May—6 months.

To William Mann, of Effra Road, Brixton, in the parish of Lambeth, in the county of Surrey, Gentleman, for his having discovered or found out, that by the application of compressed air, power and motion, can be communicated to fixed machinery, and to carriages, and other locomotive machines, and to ships, vessels, and other floating bodies. 1st June. 6 months.

To Andrew Gottlieb, of Jubilee Place, Mile End Road, in the county of Middlesex, locksmith, for his having invented certain improvements on, or additions to locks and keys. 1st June—6 months.

To John Smith, of Bradford, in the county of York, corn miller, being one of the people called Quakers, for his having invented certain improvements in machinery for dressing flour. 4th June—2 months.

To Charles Brooks, of Meltham Mills, near Huddersfield, in the county of York, cotton spinner, for his having invented certain improvements in machinery for spinning cotton and other fibrous substances. 4th June—6 months.

To Robert Porter, of Carlisle, in the county of Cumberland, iron manufacturer, for his having invented a certain improvement or improvements in the manufacture of iron heels and tips for boots and shoes. 13th June—2 months.

To Francis Day, of the Poultry, in the city of London, optician, and Auguste Münch, mechanic, of the same place, in consequence of a communication made to them by a certain foreigner residing abroad, and inventions by themselves, for an invention of certain improvements on musical instruments. 19th June—6 months.

To Charles Wheatstone, of the Strand, in the county of Middlesex, musical instrument maker, for his having invented a certain improvement or certain improvements in the construction of wind musical instruments. 19th June—6 months.

To Moses Poole, of Lincoln's Inn, in the county of Middlesex, gentleman, in consequence of a communication made to him by a certain foreigner residing abroad, for an invention of certain improved machinery for preparing or kneading dough. 19th June—6 months.

List of Patents,

GRANTED IN SCOTLAND SINCE MARCH, 1829.

For certain improvements on the Steam Engine. To John Udny, Esq. county of Middlesex.

For a certain medicine or embrocation to prevent or alleviate sea sickness. To Philip Derbyshire, Esq. county of Middlesex.

For an improvement on machinery and apparatus for embroidery or ornamenting cloths, &c. To Henry Bock, Esq. London.

For an improvement in the construction of made masts.
To Richard Green, county of Middlesex.

For an improvement in the process of making iron. To
Josias Lambert, Esq. London.

French Patents,

GRANTED IN JANUARY, FEBRUARY AND MARCH, 1829.

- To Geniez, M. A. Chaumette, Paris, for ink-stands with valves.
10 years.
- Charles Laurentpère, Paris, for an airiferous apparatus to
preserve corn. 15 years.
- Ferdinand Charles Briant, Paris, for an antiphlogistic syrup.
5 years.
- Belandine Antoine Laureys, Paris, for a coffee-boiler.
5 years.
- Jean Jacques Herbault, Paris, for a coach to carry tra-
vellers. 10 years.
- Chretien Heiligenstein, Paris, for pottery furnaces. 5 years.
- Pierre Pinomat, Amiens, for a wind instrument he calls
“ Typotom.” 5 years.
- Theodore Chenevière, Louviers, for a brushing-machine.
5 years.
- Ithier, Senior, Vienne, for a machine to spin wool. 10 years.
- Jolin Dubois, Nantes, for a machine to clear and bleach
pepper. 5 years.
- Gay Cazalat, Versailles, for an aerostatic lamp. 10 years.
- Marie Hough Delhoglie, Paris, for a coffee and chocolate,
she calls “ de Sante.” 5 years.
- Denis Joseph Bouché, Paris, for a combing machine. 10
years.
- Oneriphore Pecquar, Paris, for improvements in steam
engines. 15 years.
- Bernard Romain, Bagnols, for a method to learn to read
and to write. 10 years.
- — Simon Mialle, Paris, for a method to learn to read. 15
years.
- Pleyel and Co. Paris, for a new sort of foot, applicable to
square piano-fortes. 5 years.
- Besnier Duchaussais, Paris, for a carriage with three wheels,
“ Tricydes.” 15 years.

- To Paul Girandet, Lyons, for a process to burn gypsum. 10 years.
- Louis Baudry, Villedieu, for a process to stamp culinary vessels. 15 years.
- Maurice Daninos, Paris, for a process to manufacture hats and bonnets. 10 years.
- J. J. Gonon, Lyons, for a mechanical umbrella. 5 years.
- N. Blanchet and Roller, Paris, for a new escapement to pianofortes. 5 years.
- Joseph Rayner, London, for improvements in shearing machines. 10 years.
- Paquy, Paris, for a new method to manufacture the horse-hair applied to casques of cavalry. 5 years.
- Tirnier Prevost, Paris, for an apparatus he calls "Eusmophore." 5 years.
- Bertin, Paris, for a steam-carriage he calls "Pyrobalistics." 15 years.
- Pierre Fasanini, Lyons, for a mechanical loom. 10 years.
- Alexandre Lorgnier, Boulogne, for improvements in the manufacture of tiles. 15 years.
- Rehaist, Paris, for a lamp at constant level. 5 years.
- Leger Clerc, Lyons, for a shuttle with a retrograde motion. 5 years.
- Bourguien and Co. Lyons, for a loom bottom to weave three ribbons at once. 5 years.
- Hypolite Fuguel, Marseilles, for a machine to move heavy weights. 5 years.
- Miche Fraisse, Briare, for portable cranes. 5 years.
- Elinme Pelletier, Ladoué, for a press. 10 years.
- Debesiz, Paris, for a process to consolidate shoes, &c. 10 years.
- Chaumette, Paris, for a new system of playing cards. 15 years.
- François Dize, Paris, for an harp with double motion. 5 years.
- Mevil, Caron, and Amongaud, Paris, for a coach they call "Colibri." 5 years.
- Charles Chorreau, Paris, for a mechanical billiard. 10 years.
- A. J. Huet, Paris, for a moveable paddle water-wheel. 10 years.
- Amedéc Durant, Paris, for a portable horsewheel. 5 years.
- Alexandre Kay, Paris and Manchester, for a combing machine of flax, &c. 15 years.
- Charles Duhamel fils, Orleans, for a coach train with broken axle-trees. 5 years.
- Josui Heilmann, Mulhausen, for an embroidering machine. 15 years.

- To Pierre Fusz, Ineming, for a method to skid a coach-wheel—
10 years.
- James Collier, Paris, for process to employ a certain substance to produce light and heat. 10 years.
 - J. P. F. Collain, Sabron, for a serpentine fire-place and chimney. 15 years.
 - Joseph Croucher, London, for improvements in chronometers. 15 years.
 - Jacques Crevel, Rouen, for a method to ring the bells without moving them. 15 years.
 - Clement Pottet, Paris, for a shutting gun. 10 years.
 - Guy Frères, Paris, for machines to make bread. 15 years.
 - J. P. M. Teissier, Paris, for a process to keep razor strops in good order. 5 years.
 - Coisplet, Paris, for machinery to manufacture culinary articles. 15 years.
 - Louis George, Uzès, for a new letter case. 5 years.
 - Prosper Meyner, Lyons, for a mechanical loom button. 10 years.
 - L. P. Senechal, Paris, for improved scissors. 5 years.
 - P. H. Covillion, Cognac, for a paste to manufacture architectural ornaments. 5 years.
 - Delbourn, Paris, for improvements in pencils, slides, &c. 5 years.
 - — Morel, Paris, for a process to destroy bugs. 15 years.
 - Jean Louis Jaume, Paris, for improvements in burning lime. 15 years.
 - Jean Francois Salomon, Besançon, for an instrument he calls "Harpolyre." 5 years.
 - Soyer et Ingé, Paris, for a clock-sphere. 5 years.
 - August Laureus, Chatillon, for a method to learn to read. 5 years.
 - Alexander Fitchet, Paris, for a surety-lock. 5 years.
 - Jone et Camaret, for a serpentine boiler. 5 years.
 - P. L. Guimberteau, Paris, for a moveable coach axle-tree. 5 years.
 - J. L. Robert, Paris, for an improved coach-step. 5 years.
 - Gué, Paris, for a boat he calls "Hydrorama." 5 years.
 - Pitray et Vid, Charlestown, for a rice-mill. 15 years.
 - Villeneuve, Paris, for improvements in knives. 5 years.
 - — Truffaut, Paris, for a method to employ iron in sheathing ships. 5 years.
 - Brasseur, Senior, Paris, for an improved seal. 5 years.
 - Pascal Guesnier, Rouen, for an hydraulic bed. 5 years.
 - — Chaumette, Paris, for a mechanical process to promote salubrity in towns. 10 years.

CELESTIAL PHENOMENA, FOR JULY, 1829

D.	H.	M.	S.		D.	H.	M.	S.	
1	5	0	0) in conj. with ♄ long. 21° in Gemini.	16	2	42	0	Ecliptic opposition, or full moon.
) lat. 4° 43' S. ♄ lat. 4° 3' S. diff. lat. 40'	16	16	0	0	☾ in conj. with β in Capri.
3	23	0	0) in conj. with ζ in Leo.	16	23	0	0	☾ in conj. with δ in Cancer.
4	3	0	0) in conj. with ε in Leo.	18	15	0	0	♄ in conj. with δ in Cancer.
4	13	0	0) in conj. with π in Leo.	18	15	0	0	☾ in conj. with θ in Aqua.
5	0	0	0	☾ Clock before the ☉ 4' 7"	19	0	0	0	♄ in conj. with ♃ long. 6° in Cancer.
6	11	0	0) in conj. with τ in Leo.					♄ lat. 1° 9' N. ♃ lat. 36' N. diff. lat. 33'
8	5	0	0	♀ in conj. with ♂ long 28° in Gemini.	20	0	0	0	☾ Clock before the ☉ 5' 56"
				♀ lat. 1° 18' N. ♂ lat. 1° 9' N. diff. lat. 9'	22	10	0	0	☾ in conj. with ο in Pisces.
8	17	0	0) in conj. with θ in Virgo.	22	17	1	0	☾ enters Leo.
8	18	31	0) in ☐ first quarter.	22	18	14	0	☾ in ☐ or last quarter.
10	0	0	0	☾ Clock before the ☉ 4' 55"	25	0	0	0	☾ Clock before the ☉ 6' 7"
10	1	0	0) in conj. with κ in Virgo.	25	0	0	0	♄ in conj. with ζ in Gemini.
11	17	0	0) in conj. with γ in Libra.	25	6	0	0	☾ in conj. with λ in Taurus
12	1	0	0) in conj. with θ in Libra.	25	7	0	0	☾ in conj. with ι δ in Taurus
12	18	0	0) in conj. with φ in Oph.	25	8	0	0	☾ in conj. with 2 ρ in Taurus
13	5	0	0	♀ in conj. with ♃ long. 5° in Cancer.	25	13	0	0	☾ in conj. with α Taurus.
				♀ lat. 1° 24' N. ♃ lat. 35' N. diff. lat. 49'	28	13	0	0	♄ in conj. with δ Gemini.
13	14	0	0	♀ in conj. with δ in Cancer.	29	0	0	0	♃ Stationary.
15	0	0	0	☾ Clock before the ☉ 5' 32"	30	0	0	0	☾ Clock before the ☉ 6" 4'
16	0	0	0	♀ Stationary.	30	5	39	0	Ecliptic conj. or new moon
					30	19	0	0	♀ in conj. with α in Leo.
					31	6	0	0) in conj. with ξ in Leo.
					31	20	0	0) in conj. with ο in Leo.
					31	20	0	0) in conj. with π in Leo.

) the waxing moon.—☾ the waning moon.
Rotherhithe. J. LEWTHWAITE.

METEOROLOGICAL JOURNAL, FOR MAY AND JUNE, 1829.

1829.	Thermo.		Barometer.		Rain in inches.	1829.	Thermo.		Barometer.		Rain in inches.
	Hig.	Low	Hig.	Low.			Hig.	Low	Hig.	Low.	
MAY						JUNE					
26	65	49	30,34	30,26		11	71	35	30,39	30,31	
27	67	42	30,22	30,20		12	75	47	30,26	30,24	
28	71	43	30,19	30,13		13	79	43	30,24	30,19	
29	67	45	30,13	Stat.		14	60	58	30,19	30,11	
30	60	40	30,13	30,11		15	77	49	30,06	29,90	
31	66	37	30,11	Stat.		16	62	50	29,76	Stat.	
JUNE						17	70	41	29,77	29,76	,075
1	66	49	30,16	30,12		18	64	48	29,96	29,78	,1
2	75	41	30,21	Stat.		19	69	45	29,96	Stat.	,175
3	79	55	30,16	Stat.		20	73	49	29,86	29,83	
4	73	38	29,98	29,93		21	73	55	29,74	Stat.	,125
5	67	49	29,98	29,92		22	69	53	29,76	Stat.	,125
6	59	37	30,19	30,11		23	75	55	29,89	29,77	,15
7	63	46	30,26	30,22		24	76	56	29,96	29,92	,325
8	63	45	30,26	Stat.		25	75	46	30,02	29,91	
9	65	53	30,26	Stat.	,075						
10	69	54	30,31	30,26							

Edmonton.

C. H. ADAMS.

- WOOLLEN**, apparatus for dressing the face of, by means of pumice-stone—Vizard's patent: vol. ii. p. 170.
- , machine for washing, by means of rollers—Baylis's patent: vol. iii. p. 75.
- , machine for cropping the pile from, by a peculiarly constructed rotatory cutter—Smith's patent: vol. iv. p. 69.
- , machine of a novel construction for shearing the pile of, the parts of which are peculiarly arranged, and the operation performed by a rotatory cutter—Collier's patent: vol. v. p. 1.
- , machine for shearing, having two rotatory cutters which travel over the cloth—Robinson's patent: vol. v. p. 190.
- , machine for shearing, by means of a series of vibrating blades, mounted in a frame—Hobson's patent: vol. vi. p. 241.
- , machine for shearing, by the reciprocating action of saw blades—Bainbridge's patent: vol. vii. p. 228.
- , machine for shearing, by the action of vibrating blades, under which the cloth travels—Miles's patent: vol. vii. p. 281.
- fulling or milling cloth without soap, by a paste made of rye flour: vol. viii. p. 143.
- , machine for scouring and dressing of, called a gig-mill, having wire points to act as teasles—Sevill's patent: vol. viii. p. 173.
- , machinery and apparatus for singeing the surface of, by the flame of lamps—Burn's patent: vol. ix. p. 4.
- dressing, by immersing tightly rolled cloth into steam to give it lustre. Fussel's patent: vol. ix. p. 77.
- machines having rotatory brushes and jets of steam and water, for dressing the face of—Jones's patent: vol. ix. p. 230.
- , machines for shearing and brushing the pile of, by a novel arrangement—Davis's patent: vol. ix. p. 290.
- , improved construction of rotatory knife for shearing—Austin's patent: vol. ix. p. 400.
- WOOLLEN**, machine for grinding off the pile from cloth, to produce a smooth face, instead of shearing it—Slater's patent: vol. ix. p. 406.
- machine for dressing, by means of rotatory surfaces, heated by steam and wire cards—Daniel's patent: vol. x. p. 71.
- improved loom for weaving woollen cloth by steam power—Daniell's patent: vol. x. p. 119.
- , the production of a novel kind, to be called British cashmere—Schofield's patent: vol. x. p. 142.
- , machinery for dressing and raising the pilcof, having two gig barrels, and for pressing by hollow plates heated by steam—Lord, Robinson, and Forster's patent: vol. xi. p. 5.
- , machine for shearing the pile of, by a rotatory cutter, having also a sliding or lateral drawing movement—Gardner and Herbert's patent: vol. xi. p. 85.
- stock for fulling or milling, in which steam is substituted for soap—Hirst and Wood's patent: vol. xi. p. 244.
- improved gig-mill, for scouring and raising, having an additional cylinder—Hirst and Wood's patent: vol. xi. p. 281.
- improvements on the preceding, by which the cloth is brought in contact with both sides of the gig-barrels—Hirst, Wood, and Rogerson's patent: vol. xi. p. 282.
- fabric, a machine for steaming, brushing, and pressing, by means of rotatory brushes and heated cylinders—Haycock's patent: vol. xii. p. 132.
- , machine for milling or fulling the beaters, being worked by cranks—Bernon's patent: vol. xii. p. 170.
- , machine for dressing and finishing cloth, by means of a carding cylinder, which raises the pile, and knives, which crop or shear it—Smith's patent: vol. xii. p. 249.
- , machine for dressing cloth, in which the teasles are placed in small frames, capable of being turned round

- as they become worn—Sheppard and Flint's patent: vol. xiii. p. 88.
- WOOLLEN loom**, for weaving woollen cloth by steam power, having a peculiar mode of beating up the web—Daniell's patent: vol. xiii. p. 188.
- , method of shearing cloth by a peculiar construction of machinery, having a vibratory cutter—Sitlington's patent: vol. xiii. p. 205.
- , machine for fulling, in which the frame and the bed are of iron, and to which steam is applied to aid the operation—Williams and Ogle's patent: vol. xiv. p. 84.
- raising the pile of cloth by carding it by hand upon stone slabs—Daniell's patent: vol. i.* p. 344.
- , machine for raising and cutting the pile of cloth, in which elasticity is given to the operating parts—Sevill's patent: vol. ii.* p. 285.
- , machine for shearing cloth, not appearing to have any novelty—Marshall's patent: vol. iii.* p. 255.
- machinery for dressing cloth, having in connexion with the teasles or cards, several heated polishing surfaces which revolve—Haden's patent: vol. iii.* p. 287.
- apparatus for cleansing and dressing cloth, by means of heat passed through water vessels—Rayner's patent: vol. iii.* p. 306.
- , a counting machine, to show the number of rotations of a gig-barrel employed in dressing cloth—Walker's patent: vol. iv.* p. 19.
- , an alkaline liquor for scouring—Story and Hirst's patent: vol. iv.* p. 25.
- , a gig-mill for dressing cloth, in which rollers are introduced to relieve the friction and guard the teasles—Daniell's patent: vol. iv.* p. 334.
- fabric, an improved stock for milling cloth, in which the beaters are worked by jointed rods—Jobbins's patent: vol. v.* p. 81.
- an improved method of making hand-shears for cropping—Clutterbuck's patent: vol. v.* p. 132.
- WOOLLEN**, producing polish to the surface of, by rolling the cloth tightly upon a drum, and giving it intermitted immersions in hot and cold water—Hirst's patent: vol. vi.* p. 12.
- , raising the pile of, by the action of rotatory cards, as the cloth is passed over a hard surface: vol. vi.* p. 24.
- pressing it between plates immersed in steam or hot water: vol. vi.* p. 26.
- dressing the face of, by fillets of Indian rubber or of sponge, affixed to a gig-barrel—Harris's patent: vol. vi.* p. 258.
- , machine for shearing the pile from, having cutters affixed to a rotatory cone—Hooper's patent: vol. vii.* p. 281.
- improved gig-mill for dressing, the cloth being pressed against the barrel by a cushion or brush behind. Charlesworth and Mellor's patent: vol. viii.* p. 24.
- raising the pile on cloth by teasles, which traverse laterally as the gig barrel revolves—Ferrabee's patent: vol. viii.* p. 26.
- , dressing the face of, in considerable lengths, in vats under hydraulic pressure—Jones's patent: vol. viii.* p. 126.
- , dressing the face of, in considerable lengths, under the pressure produced by wedges—Gethen's patent: vol. viii.* p. 131.
- , improvements in the manufacture of, by giving uniform tension to the threads in the loom, and additional force to beaters in the stocks—Daniel's patent: vol. viii.* p. 198.
- machine for shearing the pile of, having a varnished cloth at the back as a bed—Foxwell and Clark's patent: vol. ix.* p. 106.
- , machinery for dressing, being an improved gig-mill in which wire cards are used—Daniell's patent: vol. ix.* p. 167.
- WORMS** driven from trees by inserting sulphur in a hole in the trunk: vol. xi. p. 268.

- WORSTED**, a new kind of crape, made from—Wilson's patent: vol. vi. p. 126.
 —. (See also Wool and Spinning.)
WORTS, apparatus for cooling, formed by narrow channels in which the hot and cold liquors flow in opposite directions—Yandal's patent: vol. xiii. p. 65.
 — mode of preparing, from undressed grain—Moore's patent: vol. ii. p. 97.
 —. (See also Brewing, Distillation, and Refrigerator).
WRITING, an improved reservoir pen for—Scheffer's patent: vol. i. p. 86.
 —, a reservoir pen for, which being made of gold or silver, will not corrode—Poulton's patent: vol. ii.* p. 260.
 —. (See also Pens and Penholders.)
YARNS, machinery for printing, to produce speckled cloths—Woodcroft's patent: vol. i.* p. 32.
YARNS. (See also Spinning, Roving, and Slubbing, Cotton, Wool, and Flax).
YEAR, on the civil and solar: vol. viii. p. 78.
 —, as divided by the Egyptians: vol. xiii. p. 144.
 — by the Athenians: vol. xiii. p. 210.
 — by the Romans: vol. xiii. p. 339.
YEAST, mode of making, for bakers, without brewing: vol. v. p. 221.
ZINC, its properties in preventing the oxydation of metals: vol. x. p. 373.
 —, improved process for preparing or producing—Benecke and Shears' patent: vol. xi. p. 131.
 — plate, printing from them, instead of stones: vol. xiii. p. 105.
 —. (See also Ships and Sheathing.)

APPENDIX,

CONTAINING SUCH SUBJECTS AS HAVE BEEN INADVERTENTLY
 OMITTED IN THE FOREGOING ANALOGICAL INDEX.

N.B.—As before, the references to the volumes which are marked with an asterisk () indicate the Second Series, those without that mark refer to the First Series.*

- ACID**, lampic, its analysis: vol. iv. p. 105.
ADVERTISEMENTS and proclamations, travelling frame for displaying—Harris's patent: vol. x. p. 237.
AERIFORMED compounds of charcoal and hydrogen, experiments on: vol. ii. p. 387.
AFRICA, notice of Campbell's second Journey in the interior of: vol. iii. p. 205.
AIR, apparatus for ascertaining the course of: vol. i.* p. 65.
ALLOY of iron to represent silver and gold: vol. xiv. p. 164
AMERICA, present state of the arts in: vol. viii. p. 312.
ANDERSONIAN Institution at Glasgow: vol. ii. p. 68.
APRICOT trees, observations on: vol. ii. p. 61.
ARCHITECTURE, notice of Elmes' lectures on: vol. ii. p. 452.
ARCTIC expedition of Captain Parry: vol. ii. p. 303.
A ROW-ROOT, the plant from which it comes: vol. iii. p. 326.
ARTS, society professedly for the encouragement of, in London; its uselessness: vol. x. p. 143.
ATLAS of the stars, by Jamison, notice of its being copied from an old French one: vol. iv. p. 128.
ATMOSPHERE, experiments on its

- density at different heights: vol. iii. p. 158.
- ATMOSPHERE**, gelatinous substance, supposed to have fallen from: vol. i.* p. 367.
- BANDS** or straps for driving machinery, an improved mode of joining the ends of, by stud or metallic buttons: vol. vi.* p. 159.
- BANK** note, specimen of Perkins' new: vol. i. p. 447.
- BANKER'S** check, mode of preventing any alteration in the value of: vol. v. p. 97.
- BALANCE**, hydrostatic, for finding specific gravities: vol. ii. p. 360.
- BARK**, apparatus for extracting tanning matter from—Kendrick's patent: vol. ii. p. 171.
- BARRELS**, machinery for making: vol. iii.* p. 108.
- BATHS** to produce showers, description of: vol. iii. p. 34, 84, 129.
- BATH**, causes of frequent inundations in the neighbourhood of: vol. vii. p. 79.
- BEDS**, an improved apparatus for warming: vol. viii.* p. 264.
- BEER**, hard water employed for brewing: vol. vii.* p. 239.
- , means of preserving from acetous fermentation—Aitkin's patent: vol. vii. p. 313.
- BLADDER**, apparatus for extracting the stone from by crushing, and without cutting—Lukin's patent: vol. xiii. p. 251.
- BLEACHING** and washing fabrics of linen, &c., by steam—Smith's patent: vol. vi. p. 116.
- BLOOD**, the composition of: vol. i. p. 424.
- , on the coagulation of: vol. iii. p. 162.
- BLOWING** machinery for producing a blast for the furnace—Vaughan's patent: vol. ii. p. 261.
- , machinery for—Jefferies and Halley's patent: vol. ii. p. 282.
- machine on a rotary principle—Powell's patent: vol. x. p. 343.
- BLINDS** for windows: vol. iii.* p. 269.
- BOILERS**, improved method of feeding them with water: vol. v. p. 273.
- BOILER**, on the explosion of, at Lyons: vol. xiii. p. 346.
- , improved construction of: vol. vi.* p. 100.
- BRICKS**, machine for making: vol. iii.* p. 107.
- BRUSHES**, an improved mode of arranging the bristles and cementing them—Robinson's patent: vol. ii.* p. 11.
- CANAL**, mode of transferring vessels from one lock to another by lifting them in a cradle—Brownill's patent: vol. vii.* p. 78.
- CARRIAGE**, peculiar construction and arrangement of the body—Wall's patent: vol. i. p. 14.
- , impelled by internal machinery, worked by the hands and feet of the passengers—Baynes's patent: vol. i. p. 254.
- CATTLE**, medicines for: vol. iii. p. 141.
- CEMENT** or artificial stone, for covering houses—Pew's patent: vol. viii. p. 19.
- CHAIN**, improved form of links for gearing into toothed wheels: vol. vi.* p. 157.
- CHANDELIERS** formed to resemble cut glass, by crystallized salt attached to the frame: vol. vi.* p. 98.
- CHIMNEY**, directions for constructing: vol. x. p. 324.
- CHRONOMETERS**, on tempering the springs for: vol. vi.* p. 313.
- CIRCLE**, mode of obtaining the superficial area and quadrature of: vol. iv. p. 53.
- CLOCKS**, illuminating dials of: vol. xiv. p. 379.
- CLOTH**, machine for washing and scouring woollen—Baylis's patent: vol. iii.* p. 75.
- CLIMATES**, on the changes of temperature in: vol. viii.* p. 88.
- COAL**, experiments on the heating qualities of, various kinds: vol. x. p. 87.
- COAL-TAR**, decomposition of, and its conversion into gas: vol. vi. p. 150.
- COLD**, probable cause of its preponderance in high southern latitudes: vol. i. p. 371.

- COLUMBUS**, notice of Irvin's history and voyages of: vol. i. p. 102.
- COMET**, the path of, as seen from July to Sept. 1824: vol. viii. p. 222.
- COMPASS**, on the retrograde variation of: vol. i. p. 224.
- , improved construction of, for navigation: vol. xii. p. 126.
- COOKING**, a novel apparatus for: vol. viii.* p. 294.
- COOLING** and ventilating rooms—Valance's patent: vol. iii. p. 292.
- CORD**, improved method of twisting it for laces—Head's patent: vol. xii. p. 24.
- COTTON**, machine for picking, driven by a treadle: vol. iii.* p. 266.
- , machine for cleansing the dirt and seeds from: vol. v.* p. 155.
- DESIGN**, notice of a treatise on the art of: vol. ii. p. 157.
- DISCOVERY**, notice of a French voyage of: vol. i. p. 468.
- , notice of a Russian expedition for: vol. iv. p. 220.
- DISTILLING**, improved apparatus for—Deurbroucq's patent: vol. iv. p. 15.
- , improved apparatus for: vol. xiv. p. 44.
- DOOR**, spring for closing: vol. vi. p. 279.
- DRAWING**, a new mode of producing landscapes by black lead dust: vol. xiii. p. 35.
- DRY-ROT**, means of preventing: vol. vii.* p. 116.
- EARTHENWARE**, mode of glazing without lead: vol. v. p. 309.
- EGG**, experiments as to the changes which take place during the stages of incubation: vol. iv. p. 98.
- ELECTRICAL** apparatus, improvements in: vol. vii. p. 152.
- EMBROIDERY**, a mode of producing figures on lace by sewing on purl—Heathcoat's patent: vol. xii. p. 94.
- ENGINE**, to be worked by compressed air or steam as a moving power—Lilley's patent: vol. i. p. 324.
- ENGRAVING** or etching, on a new material for biting in the etched lines: vol. viii. p. 21.
- ENGRAVING** on ivory: vol. xiii. p. 164.
- EXPLOSION** of the American steam vessel *Ætna*, an account of the: vol. viii. p. 44.
- , on engines working on the explosive principle: vol. viii. p. 202.
- FID**, for top-masts on a lever principle—Rotch's patent: vol. i.* p. 292.
- FIG** trees, which ripen in Sussex: vol. ii. p. 388.
- FIRE-ARMS**, notice of a repeating musket: vol. ii. p. 318.
- , notice of an improved lock for: vol. vii.* p. 89.
- FIRE-ESCAPE**, notice of a new one: vol. viii.* p. 269.
- FIRE-GRATE**, formed by peristaltic bars—Brunton's patent: vol. v. p. 122.
- FIRE-PROOF** ceilings, &c., of a house, formed by means of tiles—North's patent: vol. iv.* p. 135.
- FLOUR**, mode of restoring musty: vol. ii. p. 393.
- , restoring smutty wheat or grinding it fit for use—Hughes's patent: vol. xiii. p. 33.
- FLOWER** extraordinary, from Sumatra: vol. i. p. 395.
- FLOODGATE**, self-acting, by means of a floating vessel—Koyman's patent: vol. xiv. p. 311.
- FOOD**, use of pyrolignous acid in the preservation of: vol. i. p. 313.
- , for cattle in winter, made of fermented potatoes: vol. xiii. p. 58.
- FOSSIL** remains in Kirkdale: vol. i.* p. 53.
- FUEL**, economising it by using the waste hot water from the engine for various purposes—Descroizillie's patent: vol. vii.* p. 318.
- FRACTURED** limbs, splints made of felt saturated with shellac, for protecting the limb: vol. v.* p. 94.
- FRENCH** laws of patents, their construction, and mode of administration: vol. viii. p. 307.
- , proposed amendment of: vol. xii. p. 310.
- FUMIGATING** apparatus for sick rooms, hospitals, &c.: vol. viii.* p. 217.
- GAS**, mode of producing, from oil, for illumination: vol. i. p. 59.

- GAS**, remedy against the nuisance occasioned by the refuse lime in purifying : vol. v. p. 305.
- GENIUS**, on the necessity of protecting needy inventive : vol. ix. p. 308 ; ii.* p. 362, 420.
- GLASS**, stained or painted : vol. ii. p. 359.
- , improvements in melting, vol. iii.* p. 276.
- GUINEA COAST**, in Africa, vol. ii. p. 434.
- HARE**, a species in Scotland which varies in colour at different seasons : vol. i. p. 150.
- HANDLES** for furniture and other articles of horn, improved mode of making—Deakin's patent : vol. vi.* p. 339.
- HEMP**, mode of preparing it for manufacturing purposes : vol. iii.* p. 274.
- HONE**, soap a substitute for oil in setting edge-tools upon a : vol. ii. p. 208.
- HOT AIR BLAST** for furnaces: Neilson's patent : vol. vii.* p. 20.
- HUNTERIAN ORATION** : vol. ii.* p. 25.
- HYDRAULIC** or water rain, description of : vol. v. p. 255.
- IMPRESSION** from plants taken by lithography : vol. iii. p. 215.
- INK-BOTTLES** lined with Indian-rubber : vol. xiii. p. 219.
- INDIGO**, British, a colour obtained from the hollyhock : vol. v. p. 275.
- IRON**, effects of sea-water upon : vol. iii. p. 158.
- , on the strength of cast : vol. iv. p. 274.
- IRONING** instruments, improved mode of applying heat to—Nicholson's patent : vol. vii. p. 16.
- JAPAN** goods, improved method of working pearl shell into—Jenning and Bettridge's patent : vol. x. p. 305.
- JOINT-STOCK** companies : vol. viii. p. 253.
- KNIVES**, having steel edges upon gold or silver blades—Thompson's patent : vol. ii. p. 184.
- , domestic apparatus for cleaning and polishing—Taylor's patent : vol. xiv. p. 20.
- LAMP**, on Davy's safety, for miners : vol. ix. p. 25.
- LANGUAGES**, on the best mode of learning them : vol. i. p. 286.
- LITERARY** institutions, their history and usefulness : vol. iv. p. 318.
- LUGGAGE**, improved chains for securing, to travelling carriages—Pratt's patent : vol. vi. p. 244.
- LUMINOUS** phenomenon in the heavens : vol. ii.* p. 103.
- MANUFACTORIES** of this country constantly visited by foreign spies : vol. iii.* p. 164.
- MAGNETIC** phenomenon produced by electricity : vol. ii. p. 383.
- MATTING** made from the inner bark of the bramble : vol. iii. p. 129.
- MEASURING** the quantity and specific gravity of fluids—Brunton's patent : vol. iii.* p. 293.
- MEASURE** for garments by a triangular ruler : vol. iii.* p. 326.
- MEDICINE** for various diseases : vol. iii. p. 259.
- MERCHANT-SEAMEN'S** institution, proposition of forming one : vol. ii. p. 60 ; vol. iv. p. 209.
- METEORIC** iron, a sword-blade made of : vol. i. p. 227.
- MILLS** for prison discipline—Hase's patent : vol. viii. p. 119.
- MINES**, life protected in descending into foul air in : vol. ix. p. 258.
- MORTICING** and tenoning, a machine for : vol. iii.* p. 272.
- and sawing : vol. v.* p. 95.
- MOULDS** for casting, made elastic in order that they may be readily withdrawn from the hollow parts of the pattern : vol. xiii. p. 39.
- MUSIC**, improved mode of fitting the hammer heads of pianofortes : vol. iii.* p. 162.
- NORTH WEST** expedition overland by Capt. Franklin : vol. iv. p. 269.
- NUBIA**, some account of a journey there : vol. iii. p. 159.
- OCEAN**, the effect of sinking sealed bottles in the : vol. iii. p. 153.
- OIL**, fixed, on the inflammability of : vol. ii. p. 60, 74.

- OIL** from coal, its applicability to lamps: vol. ii. p. 298.
- , process of purifying fish: vol. iii. p. 329.
- sea elephant's, from New South Wales: vol. v. p. 263.
- , castor, mode of expressing it from castor beans: vol. i.* p. 366.
- paintings, mode of copying them by lithography: vol. xiv. p. 100; vol. i.* p. 31.
- PAPER** for drawing, called lino-stereo tablets; vol. iii. p. 101, 262; vol. iv. p. 32.
- , machine for cutting rags for the making of: vol. iii.* p. 268.
- , preparing straw for making: vol. vi.* p. 25.
- PASTEBOARD**, machine for cutting and pasting—Dickinson's patent: vol. x. p. 354.
- PATENT** laws, report of evidence taken before the House of Commons on the: vol. iv.* p. 86, 147, 207, 289, 315; vol. v.* p. 34, 96, 158, 223, 285, 356; vol. vi.* p. 31, 101, 163.
- appendix to evidence: vol. vi.* p. 228, 292, 350; vol. vii.* p. 41, 92, 162, 293, 345; vol. viii.* p. 38, 100, 159, 219, 279, 331.
- PATENTS** in Great Britain, strictures on the laws of, as respects their costs and bearings on mechanical ingenuity: vol. i. p. 358.
- vol. xiii. p. 278.
- vol. v.* p. 1, 57, 127, 297; vol. vi.* p. 121, 341; vol. vii.* p. 9, 33, 195.
- PATENT** laws of France: vol. viii. p. 307.
- vol. xii. p. 310.
- laws of Prussia: vol. ix. p. 374.
- laws of Austria, vol. ix. p. 376.
- laws of the Netherlands, vol. ix. p. 377.
- laws of Spain: vol. ix. p. 378.
- PAVING**, observations on Macnamara's: vol. iv. p. 85.
- PEDOMATIVE** carriage, impelled by the rider—Baynes's patent: vol. i. p. 254.
- carriage, notice of one: vol. ii. p. 39.
- PERPETUAL** motion, observations on Congreve's: vol. xiii. p. 153.
- PIANOFORTE**, observations on the modes of improving their tones: vol. ii. p. 439.
- PIPES** of block tin for the conveyance of gas: vol. ii. p. 303.
- PISTON**, on Barton's improved: vol. xiv. p. 40.
- PLATINA** lamp, improvements in: vol. viii.* p. 91.
- PLYMOUTH** breakwater: vol. ii. p. 362.
- POWER**, obtained by suddenly heating and cooling gas—Brunel's patent: vol. xii. p. 1.
- , a self-moving, for winding up clocks: vol. vi.* p. 98.
- of animals, a new mode of applying it to machinery—Brandreth's patent: vol. ix.* p. 187.
- PRESS**, obtained by a rotary spiral lever—Barclay's patent: vol. iii. p. 175.
- PRINTING**, an enlarged design from a small plate: vol. i. p. 388.
- , notice of a new process of: vol. ii. p. 456.
- calico by a new mode of transferring the subject from plates to rollers: vol. v. p. 151.
- press, new construction of: vol. i.* p. 133.
- PROPELLING**, by machinery on the lazy-tongs principle—Neale's patent: vol. iv.* p. 126.
- , by paddles which severally revolve on their respective bearings—Cochrane's patent: vol. ix.* p. 156.
- carriages on railways, formed by suspended rods—Dick's patent: vol. ix.* p. 168.
- carriages by a horse placed within the vehicle upon a sliding platform, which he pushes back, with his feet for the purpose of actuating gear connected with the running wheels—Brandreth's patent: vol. ix.* p. 187.
- PROTRACTOR**, on a new construction for drawing angles: vol. xiii. p. 41.
- PRUSSIC** acid, its use in medicine: vol. iii. p. 260.
- , experiments to ascertain the best mode of preparing and applying it as a medicine: vol. iv. p. 218.

- PUMP**, on a new plan : vol. iii.* p. 163.
 — for drawing beer : vol. iii.* p. 273.
- PYROLIGNOUS acid**, its manufacture and uses : vol. ii. p. 152.
 —, mode of purifying it by animal charcoal : vol. xii. p. 273.
- RAILWAY**, improved means of conducting carriages on, by stationary engines—Thompson's patent : vol. iii. p. 65.
 —, improved construction of, by combining cast and wrought iron in the lines of rails—Losh's patent : vol. iii. p. 242.
- RAILWAY**, transferring bodies from one level to another on—Brownill's patent : vol. vii.* p. 78.
- REAPING** corn before it is ripe, the advantages of : vol. i. p. 400.
- REFRACTION**, an instrument for illustrating the principles of : vol. iv.* p. 258.
- REFRIGERATOR** for brewers, on a new construction : vol. x. p. 321.
 —, for cooling water to produce ice—Vallance's patent : vol. xi. p. 298.
 —, notice of—Yandal's patent : vol. xii. p. 368.
 —, for cooling worts or wash—More's patent : vol. ii.* p. 97.
 —, for cooling liquors by the immersion of a vessel of ice—Jarrin's patent : vol. iii.* p. 260.
- RICE** and other seeds, a method of hulling and cleaning : vol. v.* p. 94.
- RIGGING**, an improvement in staysails for—Heathcoat's patent : vol. viii. p. 225.
- ROADS**, streets, and ways, an improved mode of placing and fixing the paving stones of : vol. ix. p. 22.
- ROCKET** with parachute, to illuminate a considerable distance of country for military observation : vol. v. p. 273.
- ROMAN** antiquities in Britain : vol. v. p. 50.
 — foot measure, its length : vol. xiii. p. 58.
- ROOF** or covering for houses made of pitch and sand : vol. ix. p. 320.
- ROBIN** employed as an article of fuel : vol. iii.* p. 267.
- ROVINGS** of cotton, machine to give consistency to, without twisting—Dyer's patent : vol. viii.* p. 74.
- RUDDER**, an improved mode of constructing the pintles for hanging—Lihon's patent : vol. iv.* p. 56.
- SAW**, an instrument for setting : vol. i.* p. 69.
- SCABBARD** or case for swords, knives, &c—Gunby's patent : vol. ix. p. 17.
- SHARPENING** knives, &c., by a cylindrical steel rod : vol. viii.* p. 218.
- SHEATHING** ships with lime and oil as a paste : vol. vii.* p. 352.
- SHEEP**, remedy for the foot rot in : vol. i. p. 399.
 —, advantages of feeding with flour : vol. vii.* p. 238.
- SHETLAND**, New South, its discovery : vol. ii. p. 200, 435 ; iii. p. 330.
- SHIPS** rendered buoyant by air vessels in the hollows or deadwood—Dickinson's patent : vol. x. p. 28.
 —, constructed with round sterns : vol. viii.* p. 92.
- SHIPWRECK**, rafts for preserving life and property : vol. i. p. 66.
 — communicating with the shore by an arrow and cord discharged from a musket : vol. ii. p. 304.
- SMELTING** metals, a fire-guard to be used by the workmen in : vol. xiv. p. 333.
 —, improvements in the process of—Jefferies' patent : vol. i.* p. 352.
- SMOKE**, preventing the escape of, from furnaces while feeding with fuel—Pritchard's patent : vol. ii. p. 90.
 —, an improved apparatus for preventing, by means of an air regulator : vol. ii. p. 122.
- SOCIETY** Isles, notice of their rapid progress in the arts : vol. x. p. 158.
- SODA**, native nitrate of, in Peru : vol. iv. p. 105.
 —, method of making a cheap soda liquor for dyers : vol. xiv. p. 376.
- SODIUM**, chlorure d'oxide de : vol. xiv. p. 225.
- SPECIFIC** gravity, apparatus for ascertaining the, of powders : vol. xii. p. 257.

- SPIRIT** of wine, mode of rectifying it by exposing it in bladders to the sun : vol. i. p. 151.
- SPINNING** fibrous material, an improved machine for—Goulding's patent: vol. xiv. p. 360.
- STEAM** engine, notice of Perkins': vol. v. p. 150.
- engine, improved valve and condenser for—Perkins' patent: vol. vii. p. 1.
- engine, on a rotary principle—benningfield and Beal's patent: vol. vii. p. 195.
- , improved mode of generating, by a contorted pipe passed through a furnace—Paul's patent: vol. x. p. 62.
- , notice of Perkins': vol. xii. p. 367; xiii. p. 29; xiv. p. 98.
- , improvements in generating—Gilman and Sowerby's patent: vol. xiii. p. 20.
- STAR** table, notice of Lynn's: vol. iii. p. 36.
- STEEL**, minimum of adhesion in: vol. xi. p. 267.
- , improved plates for engraving: vol. xi. p. 318.
- , on softening cast: vol. xii. p. 275.
- STEREOTYPE**, new mode of casting plates for printing: vol. i. p. 273.
- , improved blocks for: vol. vi.* p. 273.
- plates for maps: vol. vi.* p. 101.
- STONE**, the flexibility and strength of: vol. i. p. 460.
- , breaking by steam for road-making: vol. iv. p. 164; vi. p. 151.
- STRAW**, a machine for cutting, for food for cattle—Shorthouse's patent: vol. i. p. 332.
- STOVE**, improved, for cooking: vol. vi.* p. 100.
- STREETS**, new machine for watering: vol. ii. p. 318.
- and roads, an improved mode of laying the stones in constructing—Roland and M'Millan's patent: vol. ix.* p. 174.
- , subways under, for containing the water and gas pipes: vol. v. p. 84.
- SUGAR**, on the use of alcohol for refining: vol. xii. p. 268.
- SUN**, change in the appearances of the spots on: vol. iii. p. 300.
- SIDEROGRAPHY**, for bank notes: vol. i. p. 209.
- TANNING** by means of the husks of grapes: vol. viii.* p. 178.
- THERMOMETER**, a differential: vol. i. p. 151.
- THRASHING** machine: vol. iii.* p. 209, 267.
- THUNDER**, on the cause of the continuous rumbling noise of: vol. i. p. 445.
- TIMBER**, the great raft from Canada: vol. viii. p. 314.
- TIN** plates, the conducting powers of: vol. iv. p. 53.
- TRUCK**, on an improved plan, for raising and removing casks: vol. xii. p. 369.
- TUBES** for gun-barrels, &c.—Horton's patent: vol. vi.* p. 334.
- TYPES**, machine for casting: vol. iii.* p. 210.
- VALVE**, on the safety, for steam engines: vol. i. p. 339.
- for a water tank: vol. ii. p. 127, 199.
- VAPOUR**, applied to work an engine: vol. xi. p. 375.
- VEGETABLE** bodies, method of analysing them: vol. iv. p. 26.
- , several not known to us used as esculents in North America: vol. iii. p. 324.
- VEGETATION**, its effects upon the atmosphere: vol. ii. p. 125.
- VENTILATION** of mines: vol. i. p. 464.
- VERDIGRIS**, on the composition of: vol. iv.* p. 210.
- VESSEL**, peculiar construction of, to promote rapid progress—Willoughby's patent: vol. vii. p. 193.
- VICE**, an improved: vol. iii.* p. 213.
- VISCERA**, transposition of: vol. ii.* p. 217.
- VOYAGE** of discovery, Traycinct's: vol. ii. p. 313.
- WASHING** clothes by steam, notice of the advantages of: vol. ix. p. 31.
- , an improved machine for: vol. iii.* p. 212.

- WATER** mill, mode of driving the back-water from : vol. ii. p. 38.
 — closet, called self-acting—Downe's patent : vol. ii.* p. 196.
 — wheels, improvements in : vol. iii.* p. 107.
 —, mode of filtering it through an apparatus having several strata of different materials—Bell's patent : vol. vii.* p. 88.
- WEAVING** coach lace by an apparatus called the Jacquart—Lambert's patent : vol. ii. p. 95.
 — improvements on the preceding—Wilson's patent : vol. ii. p. 255.
- WEAVING**, further improvements on the same—Wilson's patent : vol. viii. p. 1, 68.
 — improvements in a loom worked by steam power—Daniel's patent : vol. x. p. 119.
- WEIGHING** apparatus, for ascertaining the weight of a ship and its cargo : vol. i. p. 316.
- WIRE-gauze**, pressed into forms for meat safes—Gosset's patent : vol. viii. p. 9.
- WOOL**, machine for combing—Ross's patent : vol. xii. p. 243.

FINIS.

